

CHINO

Digital Program Controller

KP2000

[General]

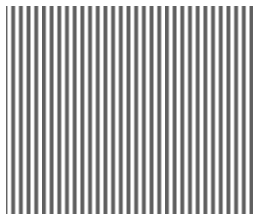

INSTRUCTIONS

CHINO

Table of Contents

| | | | |
|---|--------|---|---------|
| 1. Introduction | - 1 - | 9. Operation | - 68 - |
| 2. For safe use of the product | - 3 - | 9-1. Confirmations before operation | - 68 - |
| 2.1 Prerequisites for use..... | - 3 - | 9-2. Program operation and run operation..... | - 68 - |
| 2-2. Symbol mark..... | - 3 - | 9-3. Trial operation | - 71 - |
| 2-3. Important..... | - 4 - | 9-4. Constant value operation | - 72 - |
| 3. Model code list | - 5 - | 9-5. Automatic output operation and manual output operation. - 73 - | |
| 4. Mounting and wiring | - 6 - | 9-6. Precautions during operation | - 74 - |
| 4-1. External dimensions | - 6 - | 10. Detailed explanation of main functions - 76 - | |
| 4-2. Mounting..... | - 7 - | 10-1 Measurement range..... | - 76 - |
| 4-3. Wiring | - 9 - | 10-2 .Linear scale | - 77 - |
| 5. Name of various parts | - 20 - | 10-3. Alarm mode..... | - 78 - |
| 5-1. Entire overview | - 20 - | 10-4. Auto tuning..... | - 85 - |
| 5-2. Overview of the front panel | - 20 - | 10-5. PID control..... | - 86 - |
| 5-3. Details of the front panel | - 21 - | 10-6. Automatic PID switching system | - 87 - |
| 6. Operation screen | - 23 - | 10-7. Actuator adjustment of ON-OFF servo type.. - 88 - | |
| 6-1.Output display screen | - 23 - | 10-8. Output 2 | - 89 - |
| 6-2 Time display screen..... | - 24 - | 10-9. Transmission signal output | - 90 - |
| 6-3 Program pattern overall display screen | - 24 - | 10-10. External signal input..... | - 91 - |
| 6-4. Output display screen of output 2 specifications - 25 - | | 10-11. External signal output | - 95 - |
| 6-5. Operation screen and setting screen | - 26 - | 10-12. Timer slave synchronous operation | - 97 - |
| 7. Setting screen | - 27 - | 10-13. Communication interface..... | - 99 - |
| 7-1. Basics of setting..... | - 27 - | 10-14. Customer scale correction..... | - 100 - |
| 7-2. Mode 0 [Settings of parameters that are being executed]- 29 - | | 11. Engineering port | - 106 - |
| 7-3. Mode 1 [Settings related to operation status]. - 31 - | | 12. Trouble shooting | - 107 - |
| 7-4. Mode 2 [Settings related to program pattern].. - 34 - | | 13. Checking and maintenance | - 109 - |
| 7-5. Mode 3 [Settings related to PID and alarm] - 38 - | | 13-1. Checking..... | - 109 - |
| 7-6. Mode 4 [Settings related to output]..... | - 43 - | 13-2. Life component | - 109 - |
| 7-7. Mode 5 [Settings related to input] | - 47 - | 13-3. Disposal | - 109 - |
| 7-8. Mode 6 [Settings related to time event]..... | - 50 - | 14. Explanation of terms | - 110 - |
| 7-9. Mode 7 [Settings related to transmission output].. - 51 - | | 15. Accessories | - 114 - |
| 7-10. Mode 8 [Settings related to communications]. - 53 - | | 15-1. Front protective cover | - 114 - |
| 7-11.Mode 11 [Settings related system] | - 57 - | 15-2. Contact protection element..... | - 114 - |
| 7-12. Mode 12 [Settings related to customer scale correction]. - 60 - | | 16. Specifications | - 115 - |
| 7-13. Initializing the setup parameter..... | - 62 - | 17. Parameter list | - 119 - |
| 7-14. Precautions while setting | - 63 - | 18. Parameter directory list | - 125 - |
| 7-15. Error message | - 64 - | 19. Engineering unit sticker | - 127 - |
| 8. Initial settings | - 67 - | | |

1. Introduction

Thank you for purchasing Digital Program Controller 'KP 2000 series'.

KP 2000 series is Digital Program Controller with indicating accuracy of $\pm 0.1\%$, control cycle of approximately 0.1 seconds and front size of 96X96mm.

Universal input and storing up to 30 types of program patterns etc. are the various functionalities that are provided as standard provisions. Besides a digital indicator with large easy to view LED display, various settings have an interactive system with high resolution dot matrix LCD display and handling is also easy with precise control. Besides a digital indicator with large easy to view LED display, various settings have an interactive system with high resolution dot matrix LCD display and handling is also easy with precise control.

Understand the controller properly and read this instruction manual beforehand in order to avoid any trouble.

This is a 'General' instruction manual. For specification regarding communications, read 'Communication' instruction manual along with this manual.

Request

- For the persons doing instrumentation, installation and sales -

Be sure to handover this instruction manual to the persons using the controller.

- For the users of the controller -

Preserve this instruction manual carefully until you scrap the controller.

Write down and keep the contents of setting.

Notices

1. You should not copy or forward fully or partially this document without prior notice.
2. The contents of this document may be changed without notice.
3. We have taken enough care regarding the contents of this document however if at all you notice a mistake, contact our nearest office.
4. Please understand that regarding the result of the operation, whatever is the result the company will not be responsible.

■ Before use

After opening the pack, confirm the following before using the product. Although it is rare but if you notice anything wrong, contact your dealer or our nearest office.

1. Confirm the exterior

Confirm that the product is not broken on the outer side.

1. Confirm the model code

Confirm that the model code is that of the model that you want to purchase.

◆ Model code label and its location

A label as shown below is pasted on the upper surface of the controller unit.

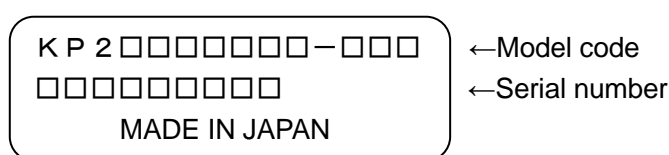

3. Confirm the accessories

The following accessories are attached to the controller, confirm them.

| Name | Quantity | Remarks |
|---|-----------|--|
| Mounting bracket | 2 (1 set) | For panel mounting |
| Contact protection element | 1 | Attached to ON-OFF servo type specifications only |
| Instruction manual (General) | 1 | This document |
| Instruction manual (Communications interface) | 1 | Attached to communications specifications only (in CD-R) |

When accessories are requested separately, sometimes those are also attached.

Attention

1. Do not drop the instrument while taking it out of the box.
2. When transporting this instrument, pack the instrument in the box and then put it with cushions in another box. We recommend keeping the box for transport.
3. When not using the instrument for a while after taking it from the panel, put the instrument in the box and store at room temperature and in a dust free atmosphere.

2. For safe use of the product

In order to use the controller safely, read the following precautions and understand them.

2.1 Prerequisites for use



The controller is a general product of component type that is to be used by mounting it in a panel for instrumentation inside a room. Do not use it in any other condition.

When using, design a fail safe on the final product side and review regularly and use the controller after confirming the safety of the system. For the wiring, adjustment and operation of the controller contact a professional having knowledge of instrumentation.

It is necessary that the people actually using this controller read this instruction manual, and have enough understanding of various precautions and the basic operations of the controller.

2-2. Symbol mark

The following symbol marks are used in the product itself and in this instruction manual hence understand the meaning of these symbol marks properly.

| Symbol mark | Meaning |
|---|---|
|  Warning | If there is a possibility of death or severe injuries then it explains the precautions to avoid that possibility. |
|  Precaution | If there is a possibility of small injuries or a possibility of the controller or its peripheral devices getting damaged then it explains the precautions to avoid those possibilities. |
|  | It is a symbol for ground terminal. Always connect the ground terminal to protective grounding. |

Warning

Perchlorate Material

This instrument uses battery with Perchlorate Material.

Special handling may apply, see

<http://www.dtsc.ca.gov/hazardouswaste/perchlorate>

2-3. Important



Warning

In order to avoid severe accidents always read these contents and understand them.

1. **Confirm the power supply voltage and wiring**

Before supplying the power to the instrument, check that the wiring is correct, power supply voltage matches with the rated voltage and grounding is done.

2. **Install over current protection device**

The controller does not have a power supply switch. Install an over current protection device (Breaker etc.) that matches the rating specifications, in the power supply of the controller.

3. **Protection of terminal**

To prevent electric shock, provide the terminal of the controller with safety measures such that the user will not directly be able to touch the final product.

4. **Installing the safety device**

Regarding the use of a device that anticipates a big loss due to failure of the controller and the peripheral devices, always install a safety device for preventing these losses and implement fail safe design in the final product. Do not use it in important utilities facilities in which human life, atomic energy, aviation, space etc, are involved.

5. **Do not put your hands inside the controller**

Do not put your hand or a tool inside the controller. You may get an injury or an electric shock.

6. **Power cut off in case of suspicion**

If there is an offensive smell, a strange noise or smoke or if the temperature increases abnormally, it is very risky hence cut off the power supply immediately and contact the dealer or our nearest office.

7. **Prohibiting repairing and remodeling**

If repairing or remodeling is necessary, contact the dealer or our nearest office. Only the service engineers appointed by our company will change the parts, do the repairing and remodeling.

8. **Strictly follow the instruction manual**

In order to use the controller correctly and safely, follow this instruction manual. Please understand beforehand that our company will not at all be responsible for any claims for injury, damage, and passive damage due to wrong use of the product.

3. Model code list

KP2 ④ ⑤ ⑥ ⑦ ⑧ ⑨ ⑩ - ⑫ ⑬ ⑭

④ Input signal

- 0 : Universal input
- 4 : 4-wire resistance thermometer

⑤ Control mode (Output 1)

- 1 : ON OFF pulse type PID
- 2 : ON OFF servo type PID (Standard specifications)
- 3 : Current output type PID
- 5 : SSR drive pulse type PID
- 6 : Voltage output type PID
- 8 : ON-OFF servo type PID (Very little load specifications)

⑥ Control mode (Output 2)*

- 0 : None
- 1 : ON-OFF pulse type PID ×1
- 3 : Current output type PID ×1
- 5 : SSR drive pulse type PID ×1
- 6 : Voltage output type PID ×1

⑦ Zone 1*

- 0 : None
- 9 : Heater snapping wire alarm
- P : External signal input 6 points
- M : External signal input 4 points + Heater snapping wire alarm ×2
- T : External signal output 6 points
- N : External signal output 4 points + Heater snapping wire alarm ×2

⑧ Zone 2*

- 0 : None
- 1 : Transmission signal output (High performance type: 4-20mA)
- 2 : Transmission signal output (High performance type:0-1V)
- 3 : Transmission signal output (High performance type:0-10V)
- 4 : Transmission signal output (High performance type: Others)
- J : Transmission signal output (General type:4-20mA)
- K : Transmission signal output (General type:0-1V)
- L : Transmission signal output (General type:0-10V)
- 9 : Heater snapping wire alarm ×2
- P : External signal input 6 points
- M : External signal input 4 points + Heater snapping wire alarm ×2
- T : External signal output 6 points
- N : External signal output 4 points + Heater snapping wire alarm ×2

⑨ Additional specifications of zone 2*

- 0 : None
- J : Transmission signal output, output 2 (General type: 4-20mA) ×3
- K : Transmission signal output, output 2 (General type: 0-1V) ×3
- L : Transmission signal output, output 2 (General type: 0-10V) ×3
- H : Transmitter power supply ×4

⑩ Zone 3*

- 0 : None
- R : Communication 1 port (RS232C) + 3 external signal inputs
- A : Communication 1 port (RS422A) + 1 external signal input
- S : Communication 1 port (RS485) + 3 external signal inputs
- B : Communication 2 port (RS232C + RS232C) + 1 external signal input
- C : Communication 2 port (RS232C + RS422A) + 1 external signal input
- D : Communication 2 port (RS232C + RS485) + 1 external signal input
- E : Communication 2 port (RS485 + RS232C) + 1 external signal input
- F : Communication 2 port (RS485 + RS422A) + 1 external signal input
- G : Communication 2 port (RS485+RS485) + 1 external signal input
- 9 : Heater snapping wire alarm ×2
- P : External signal input 6 points
- M : External signal input 4 points + Heater snapping wire alarm ×2
- T : External signal output 6 points
- N : External signal output 4 points + Heater snapping wire alarm ×2
- U : External signal input 8 points
- V : External signal input 6 points + Heater snapping wire alarm ×2
- W : External signal output 8 points
- X : External signal output 6 points + Heater snapping wire alarm ×2
- Y : External signal input 3 points + External signal output 5 points
- Z : External signal input 4 points + External signal output 4 points

⑫ Case color

- G : Gray
- B : Black

⑬ IP54 panel sealing specifications and terminal cover*

- 0 : None
- 1 : Terminal cover exists
- 2 : IP54 panel sealing specifications + No terminal cover
- 3 : IN54 panel sealing specifications + Terminal cover

⑭ Power supply voltage

- A : 100-240V(AC)
- D : 24V(AC/DC)

* Option

×1: It can be selected when control mode (output number 1) is 1, 3, 5, or 6.

×2: It can be selected when control mode (output number 1) or control mode (output number 2) is 1 or 5 (pulse type).
Heater snapping wire alarm cannot overlap with other zones.

When output 1 and output 2 are both pulse type, alarm is judged output 1 side.

×3: It can be selected when zone 2 is 1, 2, 3, or 4.

×4: It can be selected when zone 2 is 0, 1, 2, 3, 4, J, K, or L

Note: Common options of zone 1,2,3 are designated form zone 3 ordering [9], [P], [M]

4. Mounting and wiring

4-1. External dimensions

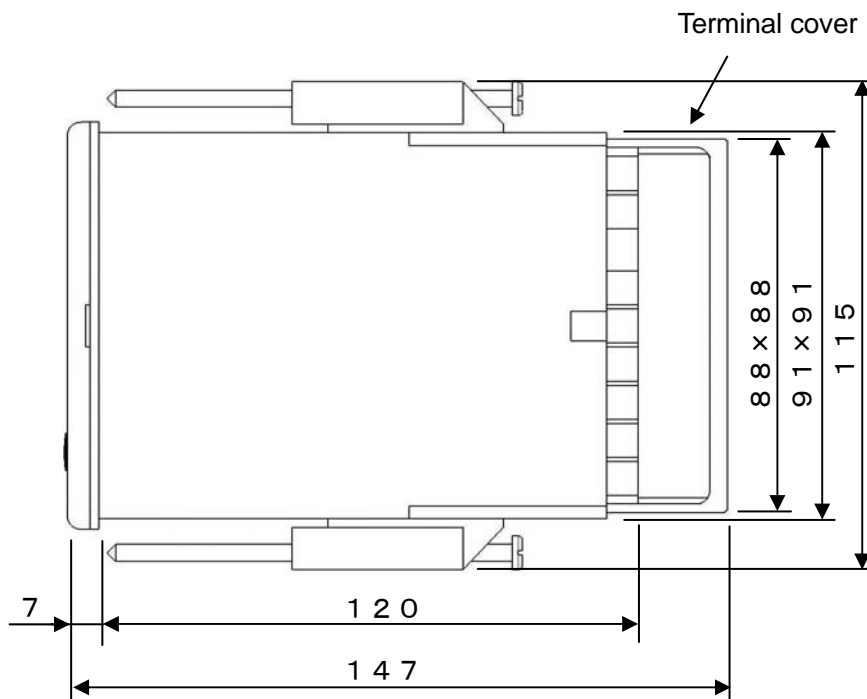
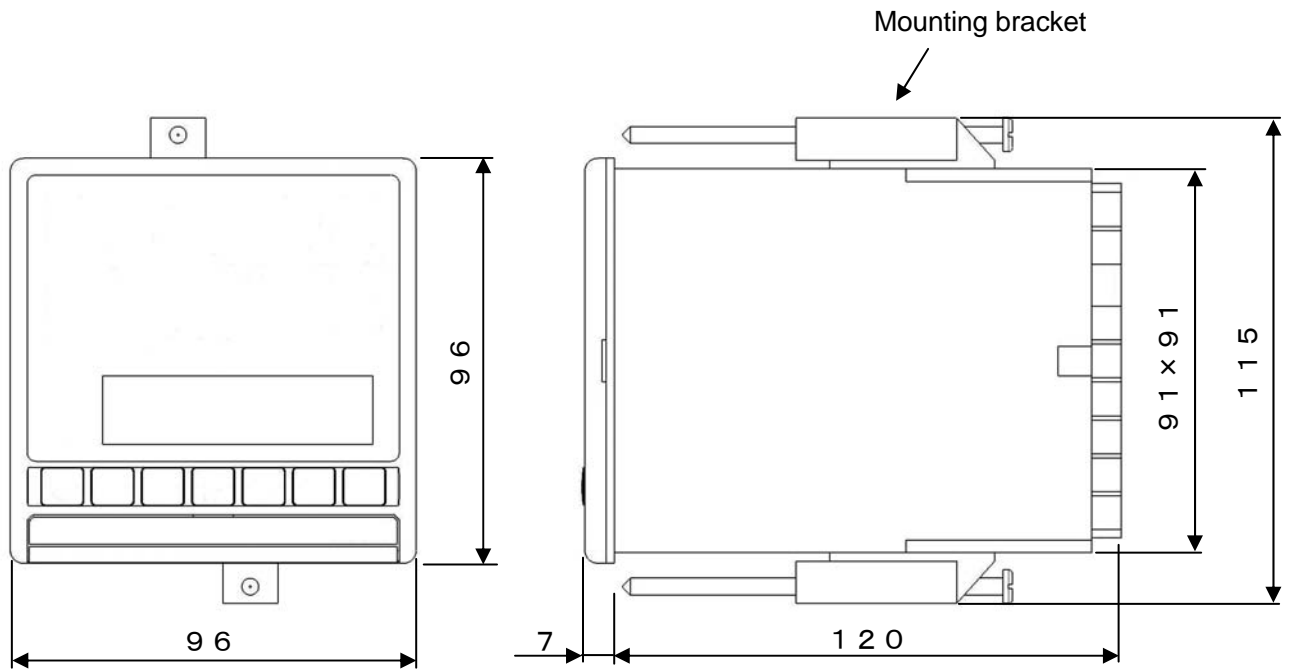

Unit: mm

4-2. Mounting

4-2-1. Panel cutout and mounting method

1. Usual mounting method

- ① Insert this product in panel cutout.
- ② Fit in the attached mounting bracket above and below and tighten the screws with the driver and fix it.
When the screws are tightened the torque is '0.6 – 0.8 Nm'.
- ③ For IP54 panel sealing specifications, confirm that the gasket between product and panels is correct.
Take care because if the gasket drifts or if there is a gap, the mounting is not proper and the water proofing function does not work.

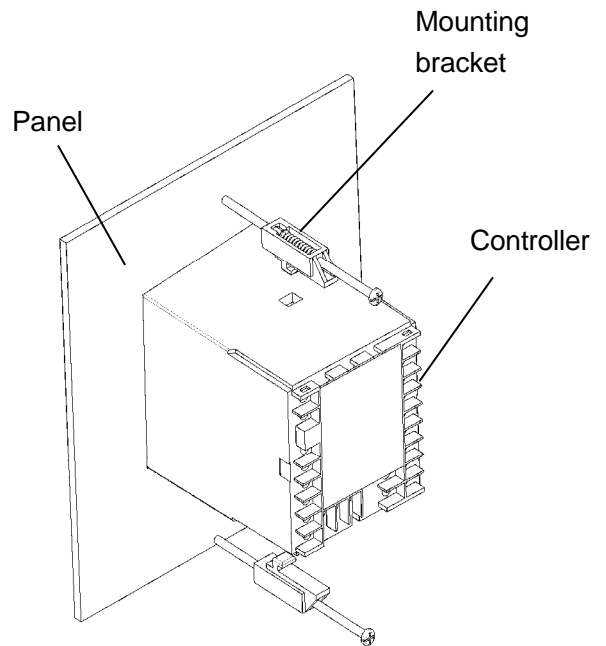
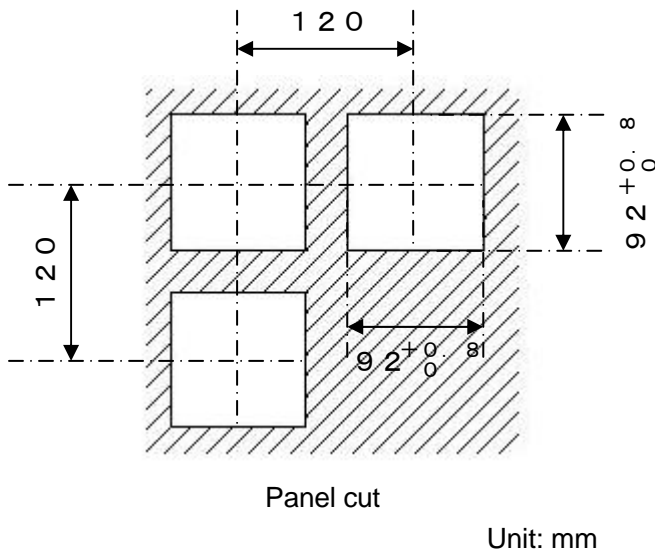

2. Closed instrumentation

- ① Insert this product in panel cutout.
- ② Fit in the attached mounting bracket above and below and tighten the screws with the driver and fix it.
When the screws are tightened the torque is '0.6 - 0.8 Nm'.
- ③ At the time of closed instrumentation, even in the product of IP54 panel sealing specifications, as the gasket functionality between the product and the panel is lost, water proofing functionality does not work.

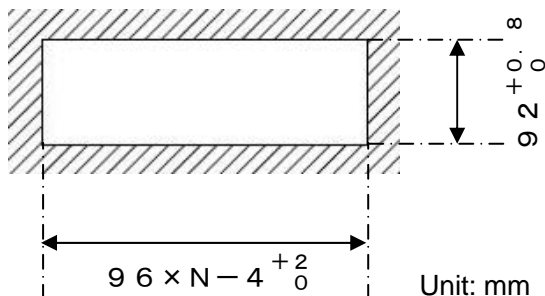

N: Number of mounted instruments
Panel cutout for closed instrumentation

4-2-2. Installation condition



Precaution

In order to avoid accidents always read and understand these contents.

1. Environment

- ① In a room.
- ② Away from direct sunlight.
- ③ Away from high temperatures.
- ④ Where there are no vibrations and shocks.
- ⑤ Away from liquids (water etc.).
- ⑥ Away from condensation.
- ⑦ Under 'Excess voltage category II , Pollution level 2' based on EN standards.

2. Atmosphere

- ① Away from strong noise, static electricity, electric field, magnetic field etc.
- ② Surrounding temperature within -10 to 50°C (Less than 40°C in case of closed instrumentation), surrounding humidity within 10-90% RH.
- ③ Variation in temperature is less.
- ④ Away from corrosive gas, explosive gas, ignition gas and combustible gas.
- ⑤ Away from salt, iron and conductive material (Carbon, iron etc.).
- ⑥ Away from steam, oil and chemicals etc.
- ⑦ Away from dust etc.
- ⑧ Away from the surroundings where high temperature is generated.
- ⑨ Away from places where temperature remains stored.
- ⑩ Lot of space above the upper part of the product.
- ⑪ Away from wind.

3. Mounting position

- ① Installation height is less than 2,000 m above the sea level
- ② Mounting position is approximately 1.5m (Approximately eye level position of a person).
- ③ Mounting orientation longitudinal tilting is less than $\pm 10^\circ$ lateral tilting is less than $\pm 10^\circ$.

4. Other

- ① Do not wipe the controller with an organic solvent (like alcohol).
- ② To avoid malfunctioning of the controller, do not use cell phones in its vicinity.
- ③ An obstacle may be created for television and radio sets placed near the controller.

4-3. Wiring

4-3-1. Terminal number and functionality

Depending on the product specifications, there are also places where terminal screw is not provided.

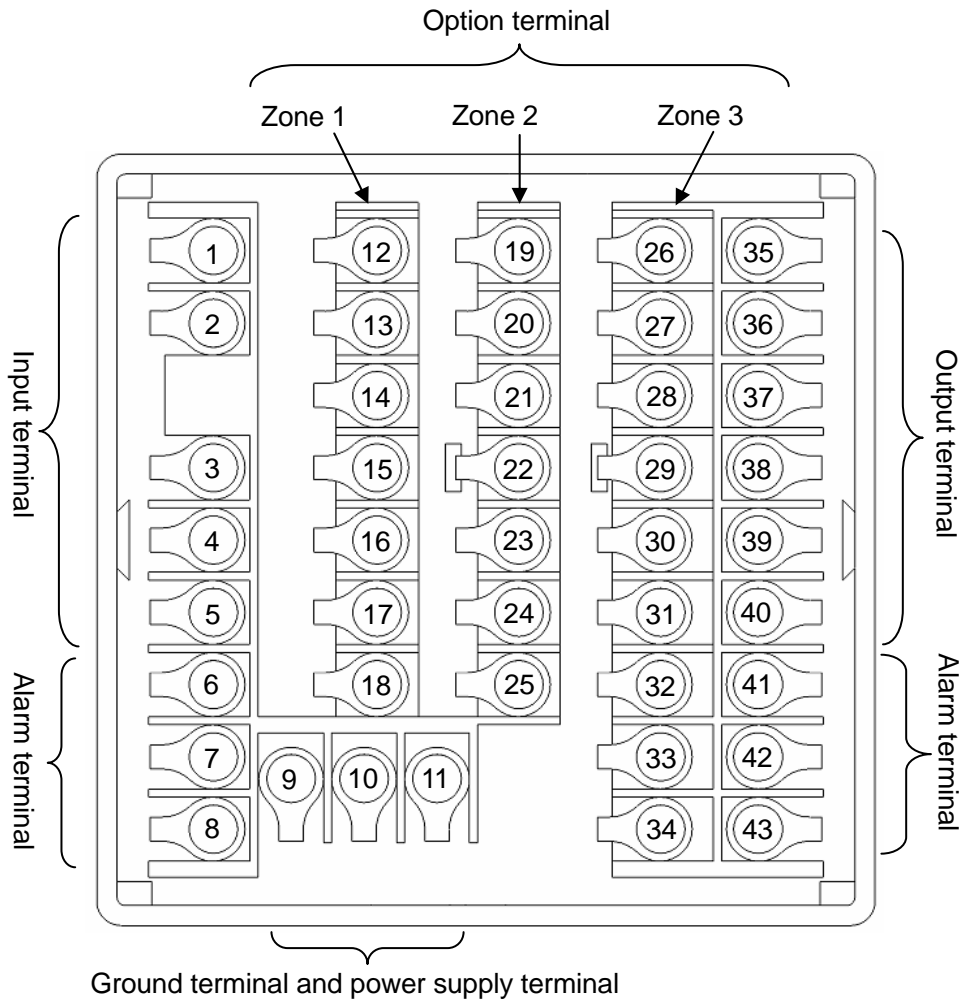

1. Power supply terminal

① General power supply specifications

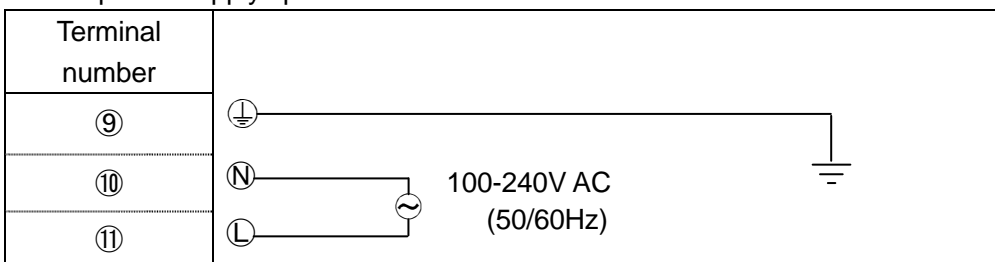

② 24V power supply specification

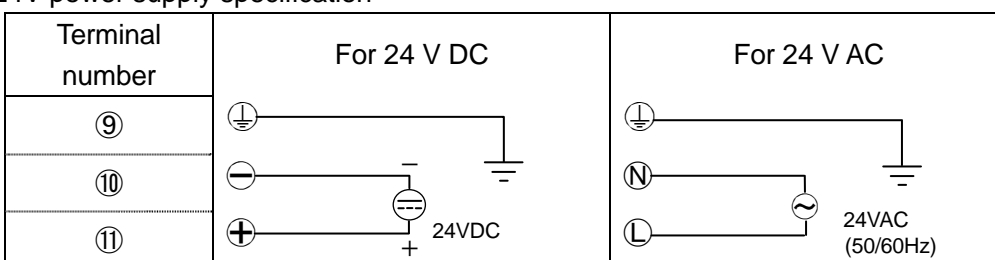

2. Input terminal

| Terminal number | Thermocouple Voltage mV | Voltage V (Range No.35) (Range No.37) | Current mA (Range No.36) | Resistance thermometer (3-wire type) | Resistance thermometer (4-wire type) |
|-----------------|-------------------------|---|-----------------------------|---|---|
| ① | | ⊕ | ⊕ | | Ⓐ |
| ② | ⊕ | | | Ⓐ | Ⓐ |
| ③ | ⊖ | ⊖ | ⊖ | Ⓑ | Ⓑ |
| ④ | | | | Ⓑ | Ⓑ |
| ⑤ | | | ⊖ | | |

Note) Do the wiring only for the specified terminals.

Note) For current mA, short circuit ③ and ⑤.

3. Output terminal

① ON-OFF pulse type

| Terminal number | Internal circuit |
|-----------------|------------------|
| Output 1 | ③⑤ N.C. |
| | ③⑥ COM. |
| | ③⑦ N.O. |
| Output 2 | ③⑧ N.C. |
| | ③⑨ COM. |
| | ③⑩ N.O. |

② ON-OFF servo type

| Terminal number | Internal circuit |
|-----------------|------------------|
| ③⑤ | CLOSE |
| ③⑥ | OPEN |
| ③⑦ | COM. |
| ③⑧ | OPEN |
| ③⑨ | COM. |
| ③⑩ | CLOSE |

③ Current output type, SSR drive pulse type, Voltage output type

| Terminal number | Current output type | SSR drive pulse type | Voltage output type |
|-----------------|---------------------|----------------------|---------------------|
| Output 1 | ③⑤ | + | + |
| | ③⑥ | - | - |
| | ③⑦ | | |
| Output 2 | ③⑧ | + | + |
| | ③⑨ | - | - |
| | ④⑩ | | |

4. Alarm terminal

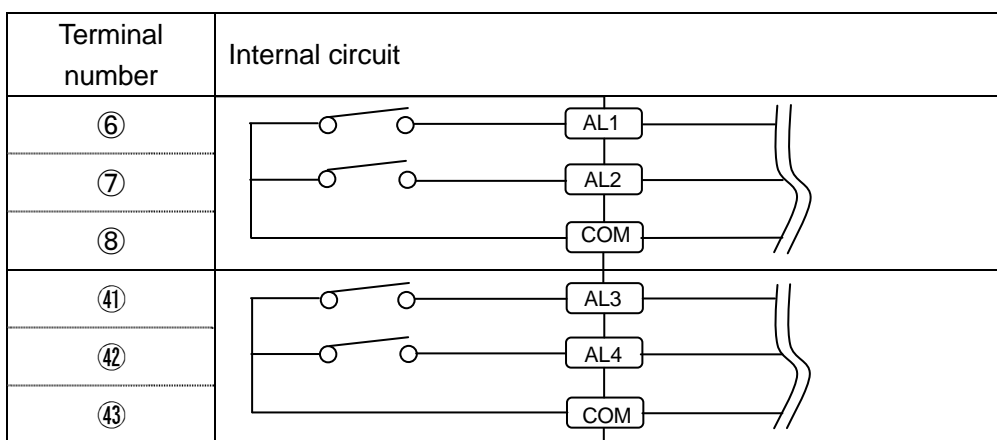

Note) Common (COM) terminal is common in AL1/AL2 and Common (COM) terminal is common in AL3/AL4.

5. Option terminal

① Zone 1

| Terminal number | Heater snapping wire alarm | External signal input 6 points | External signal output 6 points | Heater snapping wire alarm + External signal input 4 points | Heater snapping wire alarm + External signal output 4 points |
|-----------------|----------------------------|--------------------------------|---------------------------------|---|--|
| ⑫ | CT | DI | DO | CT | CT |
| ⑬ | CT | DI | DO | CT | CT |
| ⑭ | | DI | DO | DI | DO |
| ⑮ | | DI | DO | DI | DO |
| ⑯ | | DI | DO | DI | DO |
| ⑰ | | DI | DO | DI | DO |
| ⑱ | | COM | COM | COM | COM |

② Zone 2

| Terminal number | Heater snapping wire alarm | External signal input 6 points | External signal output 6 points | Heater snapping wire alarm + External signal input 4 points | Heater snapping wire alarm + External signal output 4 points |
|-----------------|----------------------------|--------------------------------|---------------------------------|---|--|
| ⑲ | CT | DI | DO | CT | CT |
| ⑳ | CT | DI | DO | CT | CT |
| ㉑ | | DI | DO | DI | DI |
| ㉒ | | DI | DO | DI | DI |
| ㉓ | | DI | DO | DI | DI |
| ㉔ | | DI | DO | DI | DI |
| ㉕ | | COM | COM | COM | COM |

| Terminal number | Transmission signal output General type | Transmission signal output High-performance type | Transmission signal output Output 2 specifications | | Transmitter power supply | Transmission signal output General type + Transmitter power supply | | Transmission signal output High-performance type + Transmitter power supply | |
|-----------------|---|--|--|-----------------------|--------------------------|--|--------------------------|---|--------------------------|
| | | | General type | High-Performance type | | Transmission output | Transmitter power supply | Transmission output | Transmitter power supply |
| ⑲ | + | | General type | + | | Transmission output | + | | |
| ⑳ | - | | General type | - | | Transmission output | - | | |
| ㉑ | | + | High-Performance type | + | | | | Transmission output | + |
| ㉒ | | - | High-Performance type | - | | | | Transmission output | - |
| ㉓ | | | | | + | Transmitter power supply | + | Transmitter power supply | + |
| ㉔ | | | | | - | Transmitter power supply | - | Transmitter power supply | - |
| ㉕ | | | | | | | | | |

③ Zone 3

| Terminal number | Communication RS-232C + External signal input 3 points | Communication RS-422A + External signal Input 1 point | Communication RS-485 + External signal input 3 points |
|-----------------|--|---|---|
| ⑳ | RD | RDA | SA |
| ㉑ | SD | RDB | SB |
| ㉒ | SG | SDA | SG |
| ㉓ | DI | SDB | DI |
| ㉔ | DI | SG | DI |
| ㉕ | DI | DI | DI |
| ㉖ | COM | COM | COM |
| ㉗ | | | |
| ㉘ | | | |

| Terminal number | Communication RS-232C (COM1) + Communication RS-232C (COM2) + External signal Input 1 point | | Communication RS-232C (COM1) + Communication RS-422A (COM2) + External signal Input 1 point | | Communication RS-232C (COM1) + Communication RS-485 (COM2) + External signal Input 1 point | | Communication RS-485 (COM1) + Communication RS-232C (COM2) + External signal Input 1 point | | Communication RS-485 (COM1) + Communication RS-422A (COM2) + External signal Input 1 point | | Communication RS-485 (COM1) + Communication RS-485 (COM2) + External signal Input 1 point | |
|-----------------|---|-----|---|------|--|-----|--|-----|--|------|---|-----|
| | | | | | | | | | | | | |
| ②⑥ | | RD1 | | RD1 | | RD1 | | SA1 | | SA1 | | SA1 |
| ②⑦ | COM1 | SD1 | COM1 | SD1 | COM1 | SD1 | COM1 | SB1 | COM1 | SB1 | COM1 | SB1 |
| ②⑧ | | SG1 | | SG1 | | SG1 | | SG1 | | SG1 | | SG1 |
| ②⑨ | | RD2 | | RDA2 | | SA2 | | RD2 | | RDA2 | | SA2 |
| ③① | COM2 | SD2 | COM2 | RDB2 | COM2 | SB2 | COM2 | SD2 | COM2 | RDB2 | COM2 | SB2 |
| ③② | | SG2 | | SDA2 | | SG2 | | SG2 | | SDA2 | | SG2 |
| ③③ | | | | SDB2 | | | | | | SDB2 | | |
| ③④ | DI | | DI | | DI | | DI | | DI | | DI | |
| ③⑤ | COM | | COM | | COM | | COM | | COM | | COM | |

Note) There is no insulation between communication 2 ports.

| Terminal number | Heater snapping wire alarm | External signal input 6 points | External signal output 6 points | Heater snapping wire alarm + External signal input 4 points | Heater snapping wire alarm + External signal output 4 points |
|-----------------|----------------------------|--------------------------------|---------------------------------|---|--|
| ②⑥ | CT | DI | DO | CT | CT |
| ②⑦ | CT | DI | DO | CT | CT |
| ②⑧ | | DI | DO | DI | DO |
| ②⑨ | | DI | DO | DI | DO |
| ③① | | DI | DO | DI | DO |
| ③② | | DI | DO | DI | DO |
| ③③ | | COM | COM | COM | COM |
| ③④ | | | | | |

| Terminal number | External signal input 8 points | External signal output 8 points | Heater snapping wire alarm + External signal input 6 points | Heater snapping wire alarm + External signal output 6 points | External signal output 5 points + External signal input 3 points | External signal output 4 points + External signal input 4 points |
|-----------------|--------------------------------|---------------------------------|---|--|--|--|
| ②⑥ | DI | DO | CT | CT | DO | DO |
| ②⑦ | DI | DO | CT | CT | DO | DO |
| ②⑧ | DI | DO | DI | DO | DO | DO |
| ②⑨ | DI | DO | DI | DO | DO | DO |
| ③① | DI | DO | DI | DO | DI | DI |
| ③② | DI | DO | DI | DO | DI | DI |
| ③③ | DI | DO | DI | DO | DI | DI |
| ③④ | COM | COM | COM | COM | COM | COM |

4-3-2. Basics of wiring



Precaution

In order to avoid accidents always read and understand these contents.

1. Connecting to the terminal

- ① For wiring of terminal use crimp style terminal with insulating sleeve. Always use O type terminal to secure safety of power supply terminal and grounding terminal. For other types of terminals also we recommend that you use O type terminal.

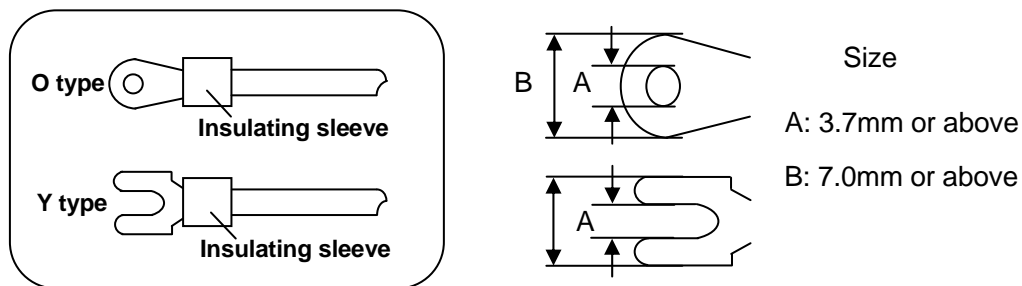

- ② When the terminal screws are tightened the torque is '0.6 - 0.8 Nm'. If a torque exceeding this value is applied, terminal screw panel gets damaged hence take care.

2. Power supply terminal

- ① In power supply, place the over current protection device and switch that conforms to the ratings of the controller, within 3m so that they are easily reachable.

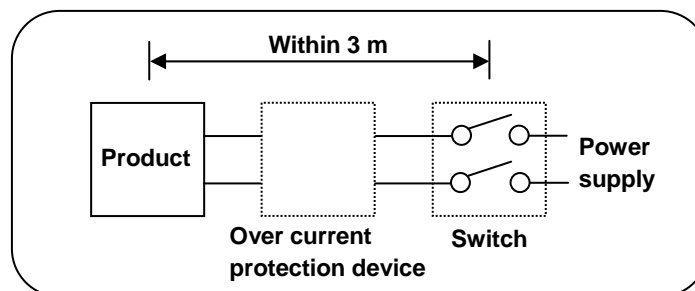

- ② Use a power supply with 600V vinyl insulation electric line (rating more than 1A AC) and an equal or greater electric line.
- ③ To avoid malfunctioning use good quality single phase power supply with little voltage change, wave form distortion and noise. If the noise is loud use noise filter and insert insulation transformer etc.
- ④ There is a little leakage of current flow in case of rated power supply hence take care. Leaking current is approximately 1mA.



Warning

To avoid serious accidents always cut off the power supply and then do the wiring.

3. Input terminal

- ① Maximum permitted input of input terminal is as follows. Take care of not applying the input that exceeds these values. If an input that exceeds the range is applied, the product may get out of order or its performance may deteriorate remarkably or it may malfunction.
 - Thermocouple, voltage mV, voltage V : Less than $\pm 20V$.
 - Resistance thermometer : Less than 500Ω or Less than $\pm 5V$.
 - Current mA : Less than $\pm 30mA$ or Less than $\pm 7.5 m$.
- ② Parallel connection of input is not allowed. Not only measurement error occurs, but also stable control is not performed and an error occurs in the entire system.
- ③ For thermocouple, do the wiring up to the input terminal of the product by a thermocouple or compensation lead wire.
- ④ To avoid measurement error for resistance thermometer, use cable such that resistance value of each wire is equal. Take care as burn out is not provided 4-wire resistance thermometer.
- ⑤ When connecting a protection device like zenner barrier for input protection, sometimes a big measurement error may occur. Confirm the combination with protection device and maintain the allowable signal source resistance and allowable wire resistance of the controller.

4. Output terminal

- ① Use an output terminal within the rating range. If a load that is out of range is connected, product may get out of order, its performance may show a remarkable deterioration or it may malfunction.
- ② For relay output terminal of ON OFF pulse type and ON OFF servo type connect the load through buffer relay. For contact protection of product internal relay and for noise reduction always insert a contact protection device on the coil side of the buffer relay. In the controller also, a small type of contact protection device is built-in for internal relay protection. Take care because a small leak current flows through this contact protection device and load voltage.
Leak current is approximately 2mA when load voltage is 200V AC and it is approximately 1mA when load voltage is 100V AC.

5. Alarm terminal

- ① Use the alarm terminal within the rating range. If a load that is out of range is applied, product may get out of order, its performance may show a remarkable deterioration or it may malfunction.
- ② For alarm terminal always connect the load through buffer relay. For contact protection of product internal relay and for noise reduction always insert a contact protection device on the coil side of the buffer relay.

6. Option terminal

- ① Use the option terminal within the rating range. If a load that is out of range is applied, product may get out of order, its performance may show a remarkable deterioration or it may malfunction.

| | |
|---|---|
|  Precaution | <ol style="list-style-type: none">① If a power supply that is out of range is connected, product may get out of order, its performance may show a remarkable deterioration or it may malfunction.② If an excess current or excess voltage is applied to input output terminal of the controller, the controller may get out of order, its performance may show a remarkable deterioration or it may malfunction. |
|---|---|

4-3-3. Example of wiring

1. ON-OFF servo type wiring

ON-OFF servo type is connected with a motor. Refer to the terminal diagram of the motor that uses three terminals of control relay output and three terminals of feedback input and do the wiring.

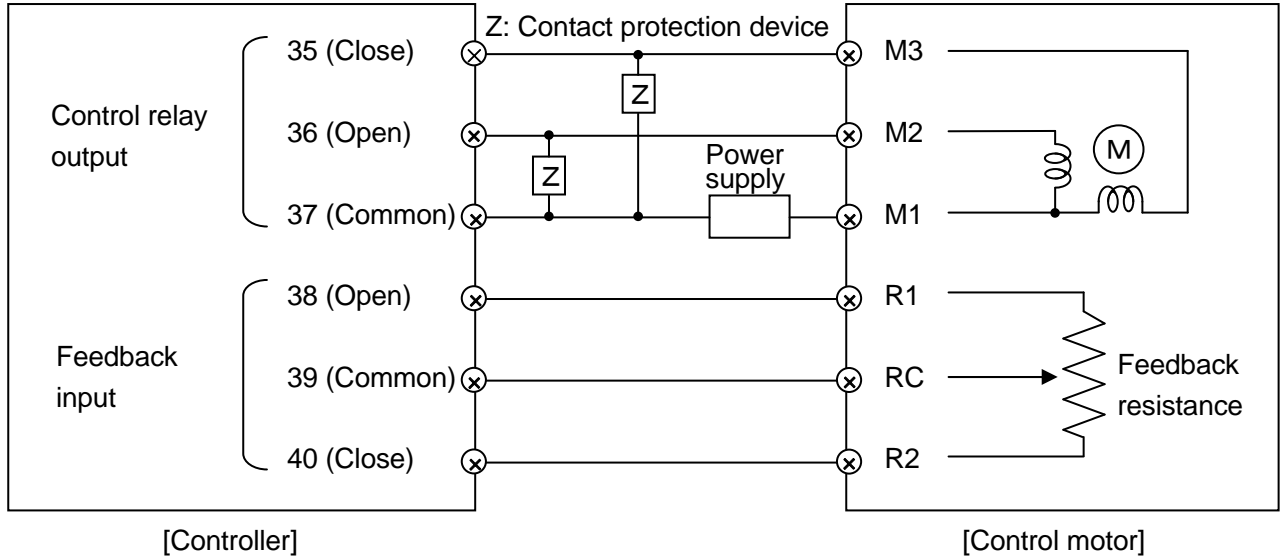

In the above diagram, the controller and control motor manufactured by our company are directly connected however, while actually connecting always insert a buffer relay and then connect. Furthermore, always connect a contact protection device in control relay output terminal.

The contact protection device attached to the controller is for the motor (For load current 700 mA and above). When connecting with buffer relay, use a contact protection device for light load. If the attached contact protection device is used in buffer relay, operation defect occurs due to leak current.

For your reference symbolic name list of motors of various companies is given below.

| Symbolic name list of motors of various companies | | | | |
|---|---------------|-------------------------------|----------------------|-------------------|
| Chino Products | Toho Products | Shin Nippon Keisetsu Products | Japan Servo Products | Yamatake Products |
| M3 | S | S | T2 | 1 |
| M2 | O | O | T1 | 2 |
| M1 | C | C | T3 | 3 |
| R1 | BM | B | B | Y |
| RC | RM | R | R | T |
| R2 | WM | W | W | G |

2. Relay output wiring example

In relay outputs like ON-OFF pulse type, ON-OFF servo type and alarm output, always connect the load through buffer relay and contact protection device.

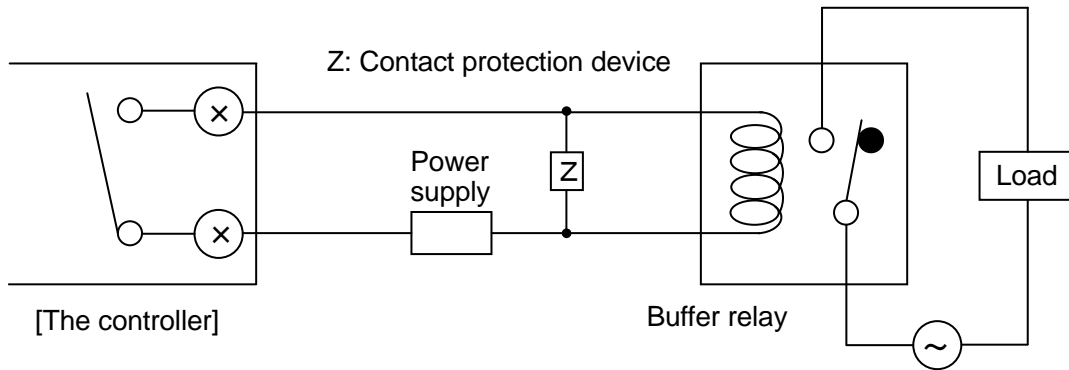

Contact protection device is handled in our company also (See 15. Accessories).

When power supply is an AC power supply, and CR compound device, and power supply have direct current, diode is generally used.

3. Wiring example of external signal input

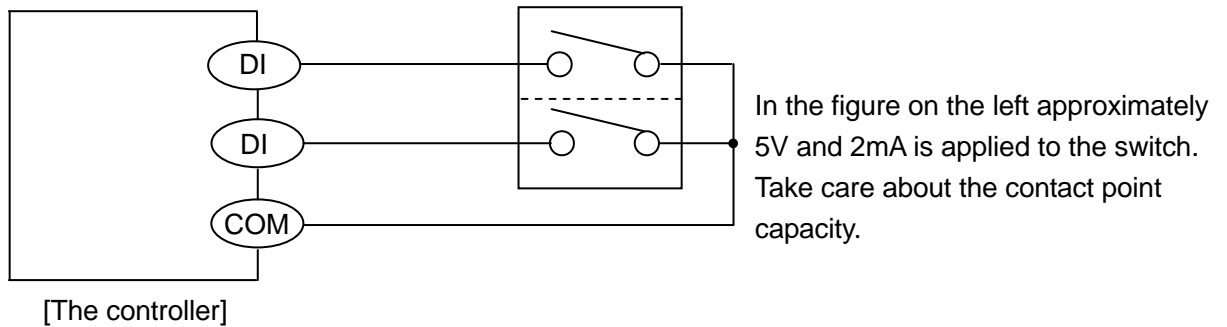

Various external signal inputs (DI) operate by short circuiting specified external signal input terminal and common (COM) terminal. Operation by switch and relay is a general method however operation by open collector output signal of peripheral device is also possible.

4. Wiring example of external signal output

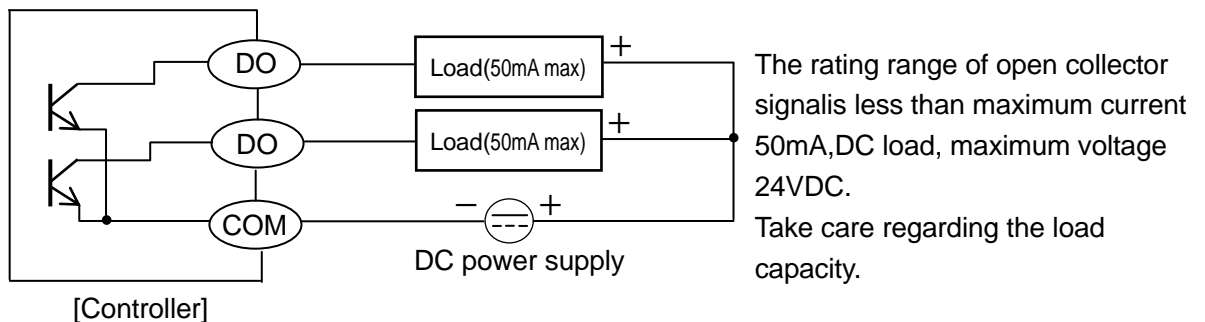

Various external signal outputs (DO) are output using open collector signals. If AC power supply is applied or load other than the rating range is applied, the controller may get out of order or its performance may deteriorate remarkably or it may malfunction.

In open collector signal if the load capacity is less, connect the load via buffer relay while referring to the following. In order to reduce noise always insert a contact protection device on the coil side of the buffer relay.

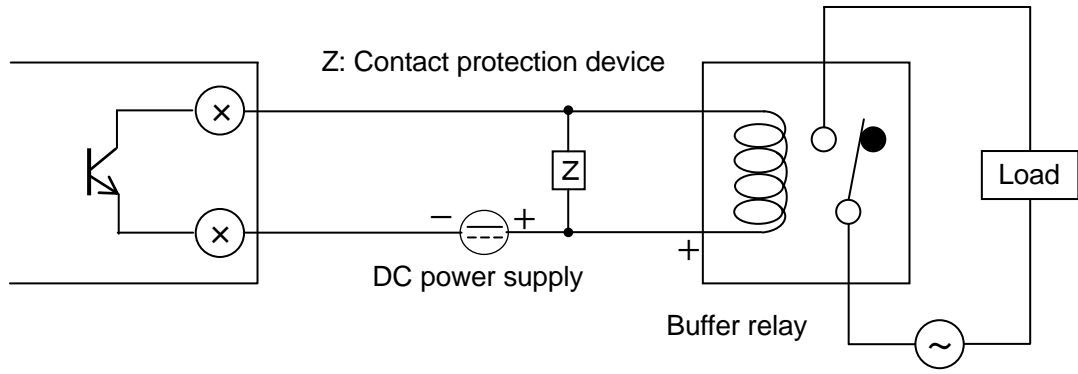

5. Wiring example of CT for heater snapping wire alarm

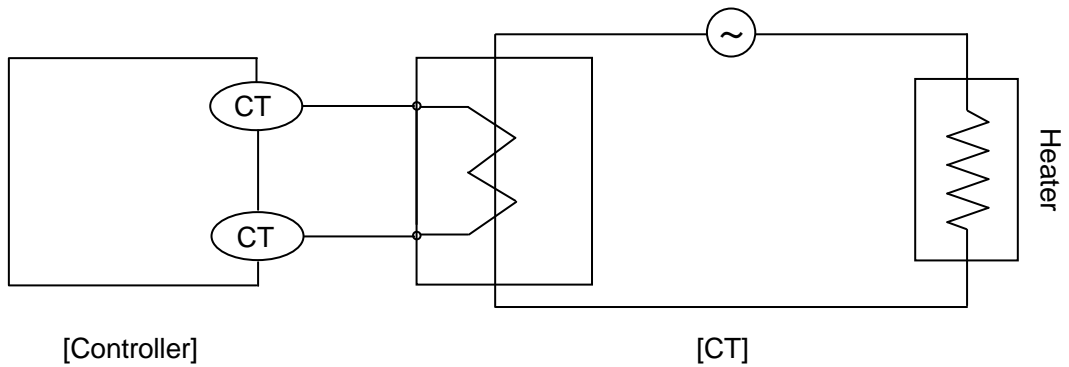

Heater snapping wire alarm judges the alarm by measuring heater current by using CT which is sold separately. Connect the electric wire to the two terminals of CT and do the wiring to the specified terminal of the controller. As for CT, customers can request it as "U-RD Company Ltd, 'CTL-12-S36-8'" directly from UR-D company.

4-3-4. Precautions while wiring



In order to avoid accidents always read and understand these contents.

1. Wiring is done by professional

Wiring is to be done by a person having actual experience and basic knowledge of instrumentation.

2. Put the terminal cover

In order to ensure safety, after the wiring is done, take measures so as to prevent direct contact with the terminal of the controller.

Exclusive terminal cover of the controller is available as accessory (Sold separately).

3. Keep away from strong electric circuit and from noise source

In order to prevent adverse effect due to noise, do not place the controller near a device from which noise is generated (magnet relay, motor, thyristor regulator, inverter etc.). Also avoid passing the wiring of the controller and that of noise generating devices through the same duct. Always keep the wiring away from each other. Take the necessary countermeasures against noise.

4. Careful about connecting ground terminal

Good grounding is important for reliability of the instrument. In most cases, it is better that each instrument is connected at a point. When connected separately, it is easy to get a bad effect due to noise. Check the connecting route.

5. Keep away from heat generating sources

In order to avoid bad effect due to high temperature, do not install the controller near heat generating sources. If the controller is kept near any heat generating source, measurement goes wrong and finally the life of the product is shortened. Take care about the surrounding temperature of the product.

Avoid places where there is wind and sudden temperature change, it also causes an error in measurement. Take necessary measures to avoid such surrounding environment.

6. Unused terminal

Do not connect anything to the unused terminal. Controller may get out of order.

7. Countermeasures against erroneous output when power is supplied

When power is supplied, sometimes the output related signal may be momentarily output when the controller is starting normally. Take the necessary countermeasures by using an external circuit.

5. Name of various parts

5-1. Entire overview

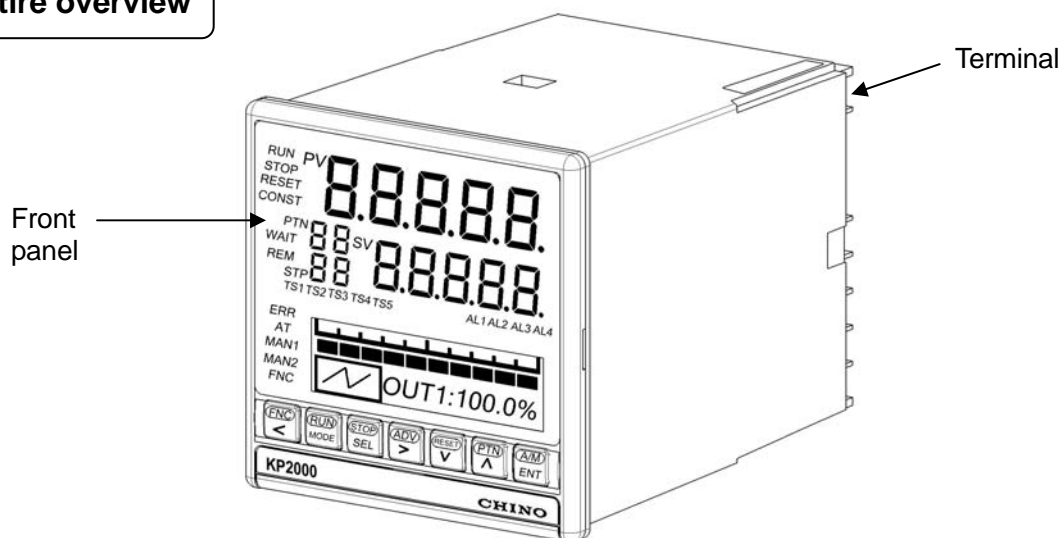

5-2. Overview of the front panel

! Caution
 This internal rack fixing screw is used at the time of maintenance. Customers please do not touch it.

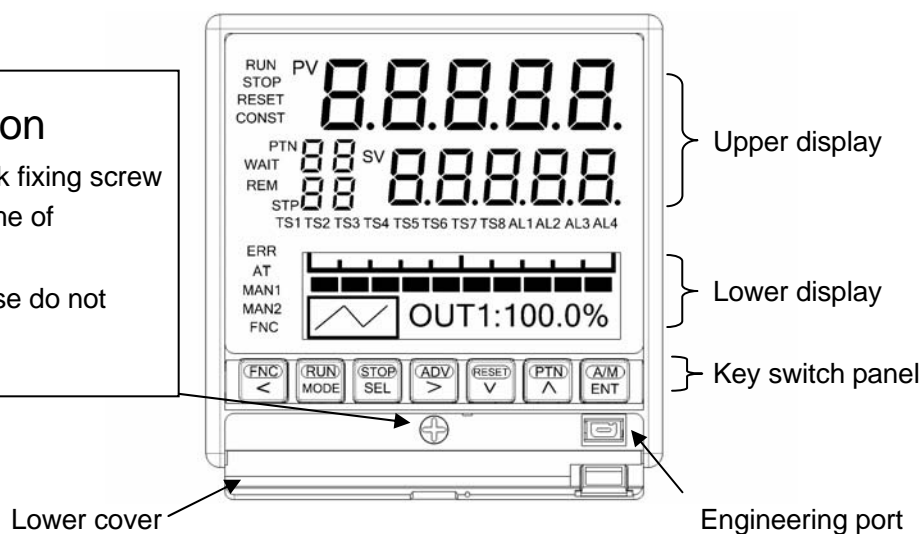



| Name | Function |
|------------------|---|
| Upper display | Displays PV, SV and each status. |
| Lower display | Displays operation screen and settings screen. |
| Key switch panel | It is used for every setting. When power is supplied or any of the key is clicked key back light (blue) illuminates (At the time of initial settings). When no key operation is done for approximately 30 seconds or more, the back light goes off automatically. This back light is illuminated till the end and brightness is uneven hence the blue color has a bright part. However it does not hinder the functionality of the product hence use it as it is. |
| Engineering port | Settings from PC can be done after connecting the exclusive engineering cable. |
| Lower cover | When using engineering port open the lower cover. At other times keep it closed tightly. |

5-3. Details of the front panel

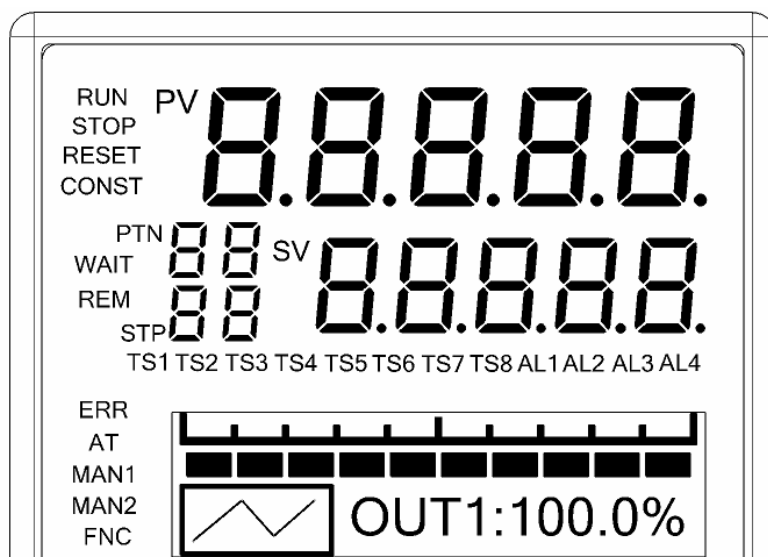



















5-3-1. Upper display



| Name | Function |
|---------|--|
| PV | Displays PV (measurement value). |
| SV | Displays SV (setting value). |
| PTN | Displays the pattern number that is being selected. Blinks when PTN is changed. |
| STP | Displays the step number that is being executed. During real temperature compensation operation, the numeral of the No. blinks. |
| RUN | Illuminates during RUN status. Blinks during FAST status. |
| STOP | Illuminates during STOP status. Blinks during WAIT status of external signal input. |
| RESET | Illuminates during RESET status. |
| CONST | Illuminates during constant value operation. |
| WAIT | Illuminates when alarm output is cancelled (Reset). Illuminates during wait status using wait alarm. Blinks during wait time alarm activation. |
| REM | Illuminates during run operation done using external signal input. (Illuminates only for the instrument with external signal input when select except 'MASTER KEY' in 'program drive system' of mode 1, or illuminates when select except 'KEY' in 'program drive system'.) |
| ERR | Illuminates when there is an abnormality in taking in the input. |
| AT | Illuminates during auto tuning operation. |
| MAN1 | Illuminates when output 1 is a manual output operation. |
| MAN2 | Illuminates when output 2 is a manual output operation. |
| TS1-TS8 | Illuminates when time signal from TS1 to TS8 is ON. |
| AL1-AL4 | Illuminates when alarm from AL1 to AL4 is ON. |
| FNC | Illuminates when  key is clicked. During illumination it is run operation key mode. If  key is clicked again the illumination goes off. The illumination may go off during run operation of external signal input or communication. |

5-3-2. Key switch panel





| Name | Function |
|---|---|
|  | <ul style="list-style-type: none"> • If it is clicked during run screen, it is run operation key mode. (For example the status is run status when  key is clicked after clicking the  key.) • When clicked during the setting screen, the mode becomes setting operation key mode and cursor moves backwards. |
|  | <ul style="list-style-type: none"> • In case of run operation key mode, it operates as RUN key. (For example the status is run status when  key is clicked after clicking the  key.) • When clicked during the setting screen, the mode becomes setting operation key mode and is used for switching the operation screen and mode screen of mode 0 and switching from setting screen to mode screen. |
|  | <ul style="list-style-type: none"> • In case of run operation key mode, it operates as STOP key. (For example in the operation screen, if  key is clicked after clicking the  key, the status becomes STOP status.) • When clicked during the operation screen, it is used for switching of operation screens. When clicked during the setting screen, the mode becomes setting operation key mode and is used for switching of settings screen. |
|  | <ul style="list-style-type: none"> • In case of run operation key mode, it operates as ADV key. (For example, the operation becomes advance operation when in operation screen,  key is clicked after clicking the  key.) • When clicked during the setting screen, the mode becomes setting operation key mode and is used for cursor forwarding or selecting a field. |
|  | <ul style="list-style-type: none"> • In case of run operation key mode, it operates as RESET key. (For example in the operation screen, if  key is clicked after clicking the  key the status is RESET status.) • When clicked during the setting screen, the mode becomes setting operation key mode and is used in descending order of setting value (setting field). |
|  | <ul style="list-style-type: none"> • In case of run operation key mode, it operates as PTN key. (For example in the operation screen, if  key is clicked after clicking the  key during RESET, the status becomes pattern number selection status.) • When clicked during the setting screen, the mode becomes setting operation key mode and is used in ascending order of setting value (or setting field) |
|  | <ul style="list-style-type: none"> • In case of run operation key mode, it operates as A/M key. (For example in output display of operation screen, if  key is clicked after clicking the  key during automatic output operation, the status becomes manual output operation status.) • When clicked during the setting screen, the mode becomes setting operation key mode and is used in registering the settings. |



6. Operation screen

Lower display window displays operation screen and settings screen. The operation screen has an output display screen whose display contents differ depending on the output format of the product, the time display screen that displays progress time of program pattern, and a overall display screen.

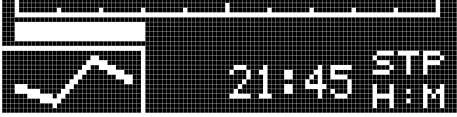
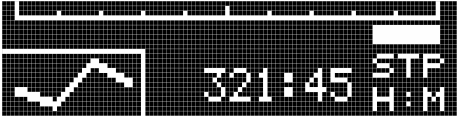

6-1. Output display screen

| Output display screen | Description of screen |
|---|--|
| <p>[ON-OFF pulse type] [SSR drive pulse type]</p>  <p>※The above is a mock display. Actually OFF and ON do not light simultaneously.</p> | <ol style="list-style-type: none"> ① On the left bottom, a snap display of three steps, the executing step in the middle and its previous and the next step are displayed. In case of RUN status, the executing step in the middle blinks. ② ON illuminates when output status is ON and OFF illuminates when output status is OFF. ③ Displays MV (output value) digitally. ④ At the time of manual output operation (manual output) 'M' on the left of 'OUT' illuminates. ⑤ In case of specifications with heater snapping wire alarm, CT measurement value is digitally displayed by 'Existence of CT screen' of mode 1. However if it cannot be measured it displays '----'. |
| <p>[Current output type] [Voltage output type]</p>  | <ol style="list-style-type: none"> ① On the left bottom, a snap display of three steps, the executing step in the middle and its previous and the next step are displayed. In case of RUN status, the executing step in the middle blinks. ② Displays a bar graph corresponding to the output value. ③ Displays MV (output value) digitally. ④ At the time of manual output operation (manual output) 'M' on the left of 'OUT' gets illuminated. |
| <p>[ON-OFF servo type]</p>  <p>※ The above is a mock display. Actually CLOSE and OPEN do not illuminate simultaneously.</p> | <ol style="list-style-type: none"> ① On the left bottom, a snap display of three steps, the executing step in the middle and its previous and the next step are displayed. In case of RUN status, the executing step in the middle blinks. ② When signal on the close side is ON CLOSE illuminates and when signal on the open side is ON OPEN illuminates. When both the signals are OFF nothing is illuminated. ③ Displays MV (output value) digitally. ④ Displays feedback value (extent of valve opening) digitally. ⑤ At the time of manual output operation (manual output) 'M' on the left of 'OUT' is illuminated. |

6-2 Time display screen



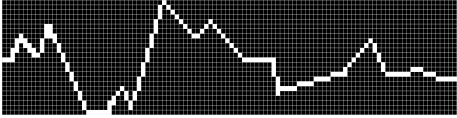
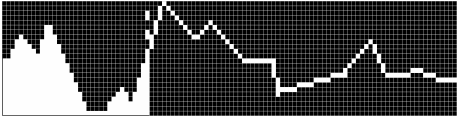

| Time display screen | Description of screen |
|---|---|
| <p>[Elapsed time display]</p>  <p>[Remaining time display]</p>  | <ol style="list-style-type: none"> ① On the left bottom, a snap display of three steps, the executing step in the middle and its previous and the next step are displayed. In case of RUN status, the executing step in the middle blinks. ② On the upper side is the bar graph corresponding to the progress time of program pattern and on the lower right its progress time is displayed digitally. ③ Progress time selects arbitrarily from four types from [Time display system] of mode 1. STP···Executing step display PTN···Executing pattern display Time format (H:M) is automatically changed/displayed depending on the length of time of pattern or step. Time display format can also be changed by using  key. |

6-3 Program pattern overall display screen

| Time display screen | Description of screen |
|--|---|
| <p>[Condition of program RESET]</p>  <p>[Condition of program RUN]</p>  <p>[Condition of program unsetting]</p>  | <ol style="list-style-type: none"> ① It is program pattern which is set at mode 2, and brief program pattern of selected setting number is displayed. ② When it is Run condition, blinking bar is displayed and the bar moves according to status. ③ If put in the STOP condition, bar is turned blink to light and stop when program is stopped. ④ Indicate horizontal axis is time and vertical axis is SV. When program pattern is not set, display [PATTERN NO SETTING]. |

6-4. Output display screen of output 2 specifications

For output 2 specifications, unlike output display screen of normal output 1 specifications, output display screen is displayed for each output.

| Output display screen of output 1 | Output display screen of output 2 |
|---|---|
| <p>[ON-OFF pulse type] [SSR drive pulse type]</p>  | <p>[ON-OFF pulse type] [SSR drive pulse type]</p>  |
| <p>[Current output type] [Voltage output type]</p>  | <p>[Current output type] [Voltage output type]</p>  |
| <p>① Operation screen of output 1 becomes 'OUT1' after adding '1' on the right of 'OUT' and thus indicates that it is an operation screen for output 1. Similarly, operation screen of output 2 becomes 'OUT2' after adding '2' on the right of 'OUT' and thus indicates that it is an operation screen for output 2.</p> <p>② Switch the output 1 operation screen and output 2 operation screen by using  key.</p> | |

6-5. Operation screen and setting screen

Relation between operation screen and settings screen is as follows.

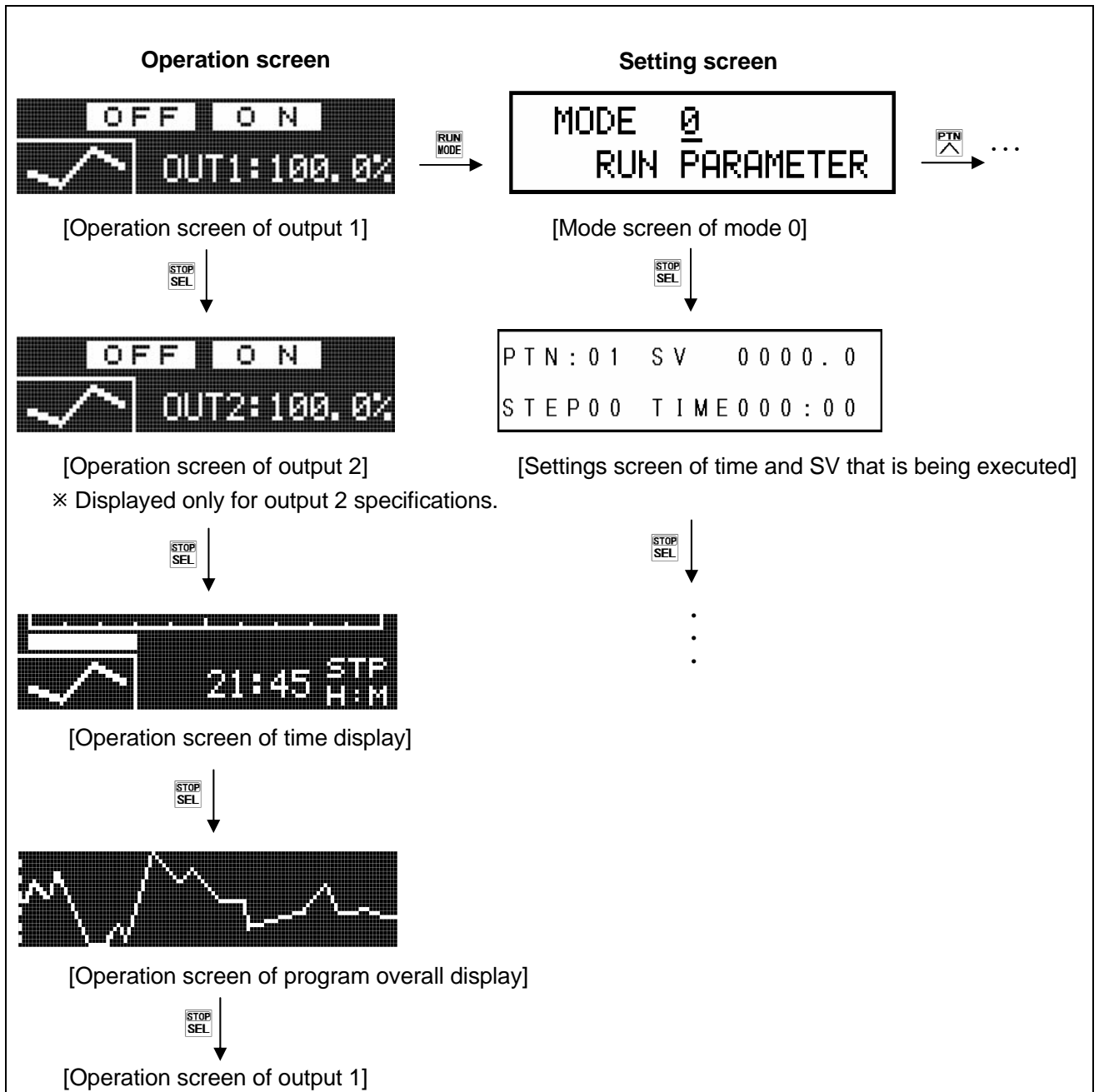



- ① When power is supplied and after initial message is displayed first of all the operation screen is displayed.
- ② In the settings screen if no key operation is done for around three minutes or more, it automatically returns to the operation screen.
However, for 'auto tuning' settings screen of mode 1, when auto tuning is executing etc., it may sometimes not return to the automatic operation screen.
- ③ Operation screen displayed lastly (either of output display screen, time display screen, or program pattern overall display screen) is stored and that operation screen is displayed after returning from power supply insertion or settings screen.

7. Setting screen

7-1. Basics of setting

7-1-1. Call up the setting screen

- ① Setting screen is grouped for every mode as mentioned in '1.8 Parameter directory list table'. Confirm number and the mode of the settings screen that is to be called up.
- ② Switching between operation screen and mode screen is done by  key, mode screen is selected by  key and setting screen is selected by using  key from mode screen respectively.

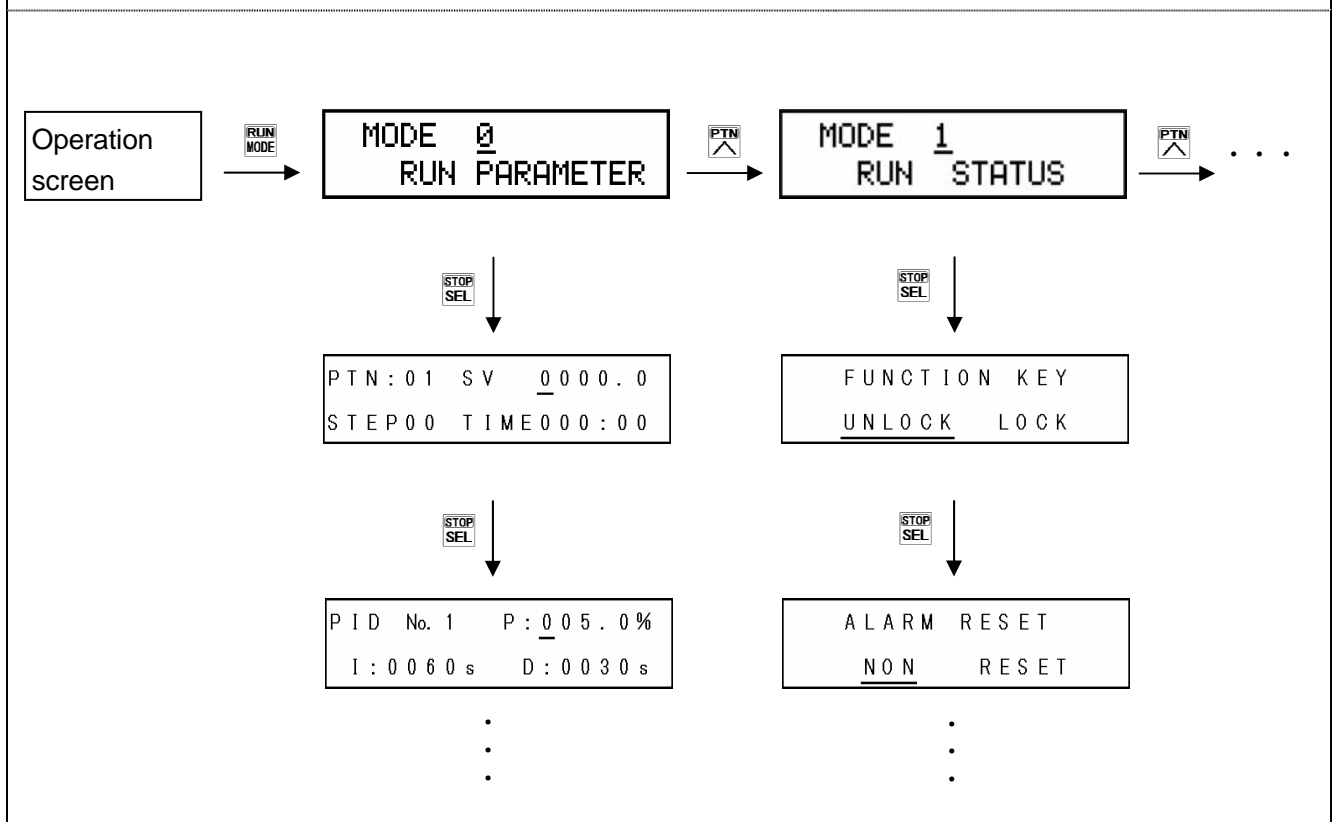

7-1-2. Basic operation of settings screen

In the settings screen, numeric value is changed and field is selected by using ADV FNC PTN RESET key and settings are completed by clicking A/M ENT key.



| Example of basic operation | |
|--|--|
| <p>1. Example of setting a numeric value</p> <div style="border: 1px solid black; padding: 5px; width: fit-content;"> P I D No. 1 P : <u>0</u> 0 5 . 0 % I : 0 0 6 0 s D : 0 0 3 0 s </div> | <p>① By using ADV FNC key the cursor is moved to the digit whose numeric value that is to be changed..</p> <p>② By using PTN RESET key the desired numeric value is selected. At that time, '?' mark is put.</p> <p>③ The value is registered by using the A/M ENT key. At that time '?' disappears.</p> |
| <p>2. Example (1) of setting a field</p> <div style="border: 1px solid black; padding: 5px; width: fit-content;"> INPUT KIND 0 5 <u>K</u> 1 </div> | <p>① By using PTN RESET key the desired field is selected. At that time '?' mark is put.</p> <p>② The field is registered by using the A/M ENT key. At that time '?' mark disappears.</p> |
| <p>3. Example (2) of setting a field</p> <div style="border: 1px solid black; padding: 5px; width: fit-content;"> MEASURE UNIT ° <u>C</u> K </div> | <p>① By using ADV FNC key the desired field is selected. At that time '?' mark is put.</p> <p>② The field is registered by using the A/M ENT key. At that time '?' mark disappears.</p> |

A convenient key operation method is given below in order to speed up the settings operation more.

| |
|---|
| <p>1. Fast forwarding the cursor</p> <p>① Usually, cursor moves by one digit by using ADV key, however by using the A/M ENT key, the cursor can be moved by, set field unit.</p> <p>② For example in the following PID settings screen, when RUN MODE key is clicked, the cursor moves as shown below.</p> <div style="text-align: center; margin: 10px 0;"> <p>'No.'</p> <div style="border: 1px solid black; padding: 5px; width: fit-content; margin: 0 auto;"> P I D No. 1 P : 0 0 5 . 0 % I : 0 0 6 0 s D : 0 0 3 0 s </div> <p style="margin: 5px 0;">A/M ENT →</p> <div style="border: 1px solid black; padding: 5px; width: fit-content; margin: 0 auto;"> P I D No. 1 P : 0 0 <u>5</u> . 0 % I : 0 0 6 0 s D : 0 0 3 0 s </div> <p style="margin: 5px 0;">↓ A/M ENT</p> <div style="display: flex; justify-content: space-around; width: 100%;"> <div style="text-align: center;"> <p>'Left most digit of the numeric value of D that is set'</p> <div style="border: 1px solid black; padding: 5px; width: fit-content; margin: 0 auto;"> P I D No. 1 P : 0 0 5 . 0 % I : 0 0 6 0 s D : 0 0 <u>3</u> 0 s </div> <p style="margin: 5px 0;">A/M ENT ←</p> </div> <div style="text-align: center;"> <p>'Left most digit of the numeric value of I that is set'</p> <div style="border: 1px solid black; padding: 5px; width: fit-content; margin: 0 auto;"> P I D No. 1 P : 0 0 5 . 0 % I : 0 0 <u>6</u> 0 s D : 0 0 3 0 s </div> </div> </div> </div> |
| <p>2. Rewinding the cursor</p> <p>Usually by using the ADV key, the cursor moves by one digit from left to right, however by clicking the FNC key, the cursor can be moved from right to left.</p> |

7-2. Mode 0

Mode 0 changes the setting of main parameters that are being executed.





| Settings screen | Description of the screen |
|---|--|
| <p>1. Mode screen</p> <div style="border: 1px solid black; padding: 5px; width: fit-content; margin: 5px 0;"> MODE 0 RUN PARAMETER </div> <p>[Lock status]</p> <div style="border: 1px solid black; padding: 5px; width: fit-content; margin: 5px 0;"> MODE 0 Lock RUN PARAMETER </div> <p>[Display OFF status]</p> <div style="border: 1px solid black; padding: 5px; width: fit-content; margin: 5px 0;"> MODE 0 NoDisp RUN PARAMETER </div> | <p>① Mode 0 screen.</p> <p>② By clicking the · key, 'Lock' and 'NoDisp' is displayed.</p> <p>③ For mode 0 settings screen, if setting change is to be prohibited select 'Lock'.</p> <p>④ When doing the settings by communications, set all the mode screens to 'Lock'.</p> <p>⑤ When settings screen of mode 0 is not displayed, 'NoDisp' is displayed.</p> |
| <p>2. SV that is being executed and time</p> <div style="border: 1px solid black; padding: 5px; width: fit-content; margin: 5px 0;"> PTN:01 SV 0000.0 STEP00 TIME000:00 </div> | <p>① SV of the executing step and the time can be changed.</p> <p>② SV setting range is within the SV scope.</p> <p>③ Change in the setting of this screen is not reflected in the setting contents of 'Program pattern' of mode 2 and is a change only for that time.</p> |
| <p>3. PID that is being executed</p> <div style="border: 1px solid black; padding: 5px; width: fit-content; margin: 5px 0;"> PID No.1 P:005.0% I:0060s D:0030s </div> | <p>① PID of the executing step can be changed.</p> <p>② Change in the setting of this screen is not reflected in the setting contents of '16 types PID' of mode 3 and is a change only for that time.</p> |
| <p>4. PID that is being executed</p> <div style="border: 1px solid black; padding: 5px; width: fit-content; margin: 5px 0;"> OUT2 PID P:005.0% I:0060s D:0030s </div> | <p>① Displayed only output 2 specification.</p> <p>② Output 2 PID of the executing step can be changed.</p> <p>③ Change in the setting of this screen is not reflected in the setting contents of 'Output 2 PID' of mode 3 and is a change only for that time.</p> |
| <p>5. Alarm 1 and Alarm 2 that are being executed</p> <div style="border: 1px solid black; padding: 5px; width: fit-content; margin: 5px 0;"> ALARM AL1/AL2 No.1 3000.0 /-1999.9 </div> | <p>① Alarm 1 and Alarm 2 of the executing step can be changed.</p> <p>② Change in the setting of this screen is not reflected in the setting contents of 'Alarm 1 and Alarm 2' of mode 3 and is a change only for that time.</p> |

| | |
|--|---|
| <p>6. Alarm 3 and Alarm 4 that are being executed</p> <div style="border: 1px solid black; padding: 5px; width: fit-content; margin: 10px auto;"> ALARM AL3/AL4 No. 1 3000.0 / -1999.9 </div> | <ol style="list-style-type: none"> ① Alarm 3 and Alarm 4 of the executing step can be changed. ② Change in the setting of this screen is not reflected in the setting contents of 'Alarm 3 and Alarm 4' of mode 3 and is a change only for that time. |
| <p>7. Output limiter that is being executed</p> <div style="border: 1px solid black; padding: 5px; width: fit-content; margin: 10px auto;"> OUTPUT LIMIT No. 1 L: 000.0% H: 100.0% </div> <p>[Output scale specification]</p> <div style="border: 1px solid black; padding: 5px; width: fit-content; margin: 10px auto;"> OUTPUT SCALE No. 1 L: 000.0% H: 100.0% </div> <p style="text-align: center;">*Option</p> | <ol style="list-style-type: none"> ① Output limiter of the executing step can be changed. ② Change in the setting of this screen is not reflected in the setting contents of 'Output limiter 8 types' of mode 4 and is a change only for that time. ③ For output scale specification (option) instead of output limiter, [output scale specification] (right below figure) is displayed. |
| <p>8. Output variation limiter that is being executed</p> <div style="border: 1px solid black; padding: 5px; width: fit-content; margin: 10px auto;"> OSL UP/DOWN No. 1 100.0% / -100.0% </div> | <ol style="list-style-type: none"> ① Output variation limiter of the executing step can be changed. ② Change in the setting of this screen is not reflected in the setting contents of 'Output variation limiter' of mode 4 and is a change only for that time. |
| <p>9. Output preset that is being executed</p> <div style="border: 1px solid black; padding: 5px; width: fit-content; margin: 10px auto;"> OUTPUT PRESET No. 1 050.0% </div> | <ol style="list-style-type: none"> ① Output preset of the executing step can be changed. ② Change in the setting of this screen is not reflected in the setting contents of 'Output preset 8 types' of mode 4 and is a change only for that time. |
| <p>10. Sensor correction that is being executed</p> <div style="border: 1px solid black; padding: 5px; width: fit-content; margin: 10px auto;"> INPUT SHIFT No. 1 0000.0 </div> | <ol style="list-style-type: none"> ① Sensor correction of the executing step can be changed. ② Change in the setting of this screen is not reflected in the setting contents of 'Sensor correction 8 types' of mode 5 and is a change only for that time. |
| <p>11. A.R.W.that is being executed</p> <div style="border: 1px solid black; padding: 5px; width: fit-content; margin: 10px auto;"> A. R. W. No. 1 L - 050.0% H 050.0% </div> | <ol style="list-style-type: none"> ① A. R. W. of the executing step can be changed. ② Change in the setting of this screen is not reflected in the setting contents of 'A.R.W.' of mode 3 and is a change only for that time. ③ This setting is operated only at the position type PID mode. |
| <p>12. Auxiliary output that is being executed</p> <div style="border: 1px solid black; padding: 5px; width: fit-content; margin: 10px auto;"> SUB OUT No. 1 001.0% </div> | <ol style="list-style-type: none"> ① It is displayed in case of specifications with transmission signal output and when transmission type 'SUB' is selected. ② Subsidiary output of executing step can be changed. ③ Change in the setting of this screen is not reflected in the setting contents of 'Subsidiary output 8 types' of mode 7 and is a change only for that time. |

| | |
|---|---|
| <p>13.SV correction</p> <div style="border: 1px solid black; padding: 5px; margin: 10px auto; width: fit-content;"> <p style="text-align: center;">SV SHIFT 000.00</p> </div> | <ol style="list-style-type: none"> ① Sets SV correction (SV bias). ② It is a function in which the entire SV is be shifted when you want to shift executing SV a little and not just the setting of program pattern is changed. This setting value is not only valid when SV correction is in executing step, but is always valid. Hence take care. ③ When measurement range, unit, measurement scope, linear scale etc is changed, sometimes decimal point position changes automatically and relatively hence take care. |
|---|---|

7-3. Mode 1

Mode 1 performs the setting related to run status.







| Settings screen | Description of the screen |
|---|---|
| <p>1. Mode screen</p> <div style="border: 1px solid black; padding: 5px; margin: 5px 0;"> <p style="text-align: center;">MODE <u>1</u> RUN STATUS</p> </div> <p>[Lock Status]</p> <div style="border: 1px solid black; padding: 5px; margin: 5px 0;"> <p style="text-align: center;">MODE <u>1</u> Lock RUN STATUS</p> </div> <p>[Display OFF status]</p> <div style="border: 1px solid black; padding: 5px; margin: 5px 0;"> <p style="text-align: center;">MODE <u>1</u> NoDisp RUN STATUS</p> </div> | <ol style="list-style-type: none"> ① Mode 1 screen. ② By clicking the · key, 'Lock' and 'NoDisp' is displayed. ③ For mode 1 settings screen, if setting change is to be prohibited select 'Lock'. ④ When doing the settings by communications, set all the mode screens to 'Lock'. ⑤ When settings screen of mode 1 is not displayed, 'NoDisp' is displayed. |
| <p>2. Run operation key lock</p> <div style="border: 1px solid black; padding: 5px; margin: 10px auto; width: fit-content;"> <p style="text-align: center;">FUNCTION KEY UNLOCK LOCK</p> </div> | <ol style="list-style-type: none"> ① Run operation key can be locked. ② If 'UNLOCK' is selected, lock is released and  becomes enabled and run operation can be done by key. ③ If 'LOCK' is selected, lock status,  key is disabled and run operation cannot be done by key. |
| <p>3. Cancel alarm output</p> <div style="border: 1px solid black; padding: 5px; margin: 10px auto; width: fit-content;"> <p style="text-align: center;">ALARM RESET NON RESET</p> </div> | <ol style="list-style-type: none"> ① When canceling temporarily the alarm output that is activated, alarm output is cancelled if 'RESET' is set. ② At that time the cursor immediately returns to 'NON' and WAIT of upper display window illuminates. ③ In cancel (WAIT) status, if you once drift away from alarm activation condition, WAIT does not get illuminated and normal status returns. ④ Take care as the settings are common for alarm output of all the 4 points. ⑤ In case of specifications with external signal input, when canceling using external signal input, it is done by external signal ON. After cancellation immediately return the external signal to OFF. |

| | |
|---|---|
| <p>4. Auto tuning</p> <div style="border: 1px solid black; padding: 5px; width: fit-content; margin: 10px auto;"> <p>P I D A U T O T U N I N G</p> <p>E N D A T 1 2 3 4</p> </div> | <ol style="list-style-type: none"> ① Auto tuning (auto calculation) of PID is done. ② From among AT1 to 4, select the desired AT and execute it. <ul style="list-style-type: none"> · AT1: AT (For output 1) in executing SV. · AT2: AT (For output 1) in SV8 types for AT2 of mode 3. · AT3: AT (For output 1) in SV8 types for AT3 of mode 3. · AT4: AT (For output 2) in executing SV. <p>However, AT4 can be selected only in case of output 2 specifications.</p> ③ When auto tuning is started, AT progress status (STEP1-STEP4) is displayed. ④ If you want to stop auto tuning in between, set 'END'. ⑤ PID calculated by auto tuning can be confirmed by setting screen of each PID. |
| <p>5. Program drive system</p> <div style="border: 1px solid black; padding: 5px; width: fit-content; margin: 10px auto;"> <p>P R O G R A M D R I V E S E T</p> <p> M A S T E R K E Y</p> </div> | <ol style="list-style-type: none"> ① Only the specifications with external signal input (DI) or with communication are displayed. ② Set program drive system. ③ If 'MASTER KEY' is selected, driving is done by front key. ④ If 'MASTER EXT' is selected, driving is done by external drive input, however, it can be selected only for specifications with external drive input. ⑤ If 'MASTER FREE' is selected, driving can be done by any of front key, external drive input and communication. However, it can be selected only for specifications with external drive input or specifications with communications. At that time any of the last drive operation, becomes the latest drive status , however last drive system type cannot be judged from external appearance hence take care. ⑥ If 'SLAVE EXT' is selected, driving is done by external signal input that is synchronized with the others. However, it can be selected only for specifications with external signal input. ⑦ If 'MASTER COM' is selected, driving is done by communication. However it can be selected only for specifications with communication. |
| <p>6. Pattern selection system</p> <div style="border: 1px solid black; padding: 5px; width: fit-content; margin: 10px auto;"> <p>P A T T E R N S E L E C T</p> <p>K E Y E X T C O M F R E E</p> </div> | <ol style="list-style-type: none"> ① Only the specifications with external signal input (DI) or with communication are displayed. ② Pattern selection system is set. ③ If 'KEY' is selected, selection is done using front key. ④ If 'EXT' is selected, selection is done using external signal input. However it can be selected only for specifications with external drive input. ⑤ If 'COM' is selected, selection is done using communication. However only the specifications with communication can be selected. ⑥ If 'FREE' is selected, selection can be done from front key or external signal input or communication. However it can be selected only for specifications with external signal input or specifications with communication. At that time any of the last selection operation, becomes the latest selection number, however last selection system type cannot be judged from external appearance hence take care. |

| | |
|--|---|
| <p>7. Time display system</p> <div style="border: 1px solid black; padding: 5px; width: fit-content; margin: 10px auto;"> <p style="text-align: center;">TIME DISPLAY SET</p> <p style="text-align: center;">PASS STEP</p> </div> | <ol style="list-style-type: none"> ① Sets the time display system of operation screen (Time display). ② If 'PASS STEP' is selected, elapsed time of the executing step is displayed. ③ If 'PASS PATTERN' is selected, elapsed time of executing pattern is displayed. ④ If 'REMAIN STEP' is selected, remaining time of the executing step is displayed. ⑤ If 'REMAIN PATTERN' is selected, remaining time of executing pattern is displayed. ⑥ In the time display screen, time display system can also be changed by  key. |
| <p>8. Control format</p> <div style="border: 1px solid black; padding: 5px; width: fit-content; margin: 10px auto;"> <p style="text-align: center;">CONTROL MODE</p> <p style="text-align: center;">PROGRAM CONST</p> </div> | <ol style="list-style-type: none"> ① Set the control format. ② If 'PROGRAM' is selected, it becomes the program operation. ③ If 'CONST' is selected, it becomes a constant value operation. When the program is running if you change to constant value operation, then it becomes a constant value operation in SV. |
| <p>9. PV hold</p> <div style="border: 1px solid black; padding: 5px; width: fit-content; margin: 10px auto;"> <p style="text-align: center;">PV HOLD</p> <p style="text-align: center;">NON HOLD</p> </div> | <ol style="list-style-type: none"> ① Measuring PV can be held (fixed). ② If 'HOLD' is set, PV is fixed with the PV value that PV had, just before the setting. ③ Status during hold is as follows. <ul style="list-style-type: none"> - Continues the control action with PV that is in hold status. - Rest everything is as per the normal operation. ④ If you want to cancel hold, set 'NON'. ⑤ When performing hold by external signal input in case of specifications with external signal input, the operation of this setting is not effective. (External signal input is the priority.) <ul style="list-style-type: none"> - External signal ON : Hold status. - External signal OFF : Cancel status. |
| <p>10. Operation when power supply is started</p> <div style="border: 1px solid black; padding: 5px; width: fit-content; margin: 10px auto;"> <p style="text-align: center;">POWER ON ACTION</p> <p style="text-align: center;">CONTINUE RESET</p> </div> | <ol style="list-style-type: none"> ① Set the operation status when starting a power supply. ② If 'CONTINUE' is selected, the status is that before the power supply cut off. ③ If 'RESET' is selected, the status is RESET status. ④ When RESET is selected and power supply is started, even though the setting screen, external signal input and communication select RUN status, the status is RESET, hence take care. In that case, by performed RUN again, the status becomes 'RUN', but pattern is started beginning. |
| <p>11. Existence of CT screen</p> <div style="border: 1px solid black; padding: 5px; width: fit-content; margin: 10px auto;"> <p style="text-align: center;">CT DISPLAY SET</p> <p style="text-align: center;">NON DISPLAY</p> </div> | <ol style="list-style-type: none"> ① Only specifications with heater wire snapping alarm are displayed. ② Set whether to display or not on the operation screen the CT measurement value for heater snapping wire judgment. ③ If 'NON' is selected, CT measurement value is not displayed. ④ If 'DISPLAY' is selected, CT measurement value is displayed. |



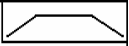

7-4. Mode 2

Mode 2 performs the setting related to program pattern.

| Settings screen | Description of the screen |
|--|---|
| <p>1. Mode screen</p>  <p>[Lock Status]</p>  <p>[Display OFF status]</p>  | <p>① Mode 2 screen.</p> <p>② By clicking the · key, 'Lock' and 'No Disp' is displayed.</p> <p>③ For mode 2 settings screen, if setting change is to be prohibited select 'Lock'.</p> <p>④ When doing the settings by communications, set all the mode screens to 'Lock'.</p> <p>⑤ When settings screen of mode 2 is not displayed, select 'NoDisp'.</p> |
| <p>2. Program pattern</p>  | <p>① Set the time and SV which is the basis of program pattern.</p> <p>② 'PTN' indicates (program) pattern, pattern numbers from 01 to 30 can be set. Select an arbitrary number and set the pattern.</p> <p>③ 'STEP' indicates step and maximum 19 steps can be set for each pattern.</p> <p>④ Set a target SV, such that 'SV' finally reaches that step. When measurement range, unit, measurement scope, linear scale etc. is changed, sometimes the decimal point position changes automatically and relatively hence take care.</p> <p>⑤ 'TIME' sets the time required for that step. Unit can be set by 'time unit' of mode 2, either of 'Hours:Minutes' or 'Minutes:Seconds' can be selected.</p> <p>⑥ Setting procedure is as follows.</p> <ul style="list-style-type: none"> • Select pattern number. • In step number 00, set setting value of start SV in 'SV' and set start system below it. Start system selects either 'SV' or 'PV'. If 'SV' is selected, it becomes SV start operation and if 'PV' is selected, it becomes PV start operation. • Consider step number 01 and set SV and time of the initial step. Setting range of SV is within the setting range. Setting range of TIME is within the range '000:00' to '999:59'. By setting '000:00', momentarily (step wise) SV can also be considered. • Similarly for next step onwards, set SV and TIME and combine it with the desired program pattern. |

| | |
|--|---|
| | <ul style="list-style-type: none"> • This procedure becomes a system called target SV system that exists in target specifications. In option there is a thing called slope SV system. In case of this system, set in 'SV' the SV variation quantity for each unit time. and set the time in 'TIME' until which that SV variation can continue. • Combine with the desired program pattern and when you want to exit the setting, set 'END/LINK00' in TIME of last step number and thus end the pattern setting. In the initial setting status 'END/LINK00' is always set in the last step. • When you want to link (link another pattern) a pattern, set the pattern number that is to be linked, in '00' on the right of LINK of 'END/LINK00' of the last step. When link several patterns and link form end pattern to first pattern, or set one of the pattern linked itself, become endless (endless loop). Then pattern repeat is not effected. • If you want to delete a certain step, set 'STEPDELETE' in TIME of step number that is to be deleted. The contents of that step get deleted and the step numbers from next step onwards are automatically updated. • If you want to insert a certain step, set 'STEPINSERT' in TIME of step number that is to be inserted. The contents which is same as each parameter of selected step get inserted and the step numbers from next step onwards are automatically updated. |
| <p>3. Repeat step</p> <div data-bbox="212 1171 563 1261" style="border: 1px solid black; padding: 5px;"> <p>PTN : 01 </p> <p>STEP01 REPEAT :</p> </div> | <ol style="list-style-type: none"> ① Set step repeat. ② It is a convenient function if you want to repeat a specific step section in an identical pattern. ③ Set '00' in REPEAT of start repeat step number and set 'repeat count' in REPEAT of end repeat step number. If 01 is set, the step repeat section that is set is repeated once, hence the entire identical step section is run twice. ④ In identical pattern, step repeat settings can be done any number of times. However duplication of repeat section and, small repetitions within large repetitions cannot be set. When setting a number of sets of step repeat, set in such a way that the '00' and repeat count settings always pair alternately in the pattern. ⑤ On the upper right part of this setting screen, snap format of step that is being set is displayed. |
| <p>4. PID number and alarm number</p> <div data-bbox="212 1861 563 1951" style="border: 1px solid black; padding: 5px;"> <p>PTN : 01 PID.....No. 1</p> <p>STEP01 ALARM...No. 1</p> </div> | <ol style="list-style-type: none"> ① Set the PID number and alarm number for each pattern/step that are set. ② Set PID number from 1 to 9 and alarm number from 1 to 8. Number 0 can also be set. When 0 is set, it becomes a function for continuing with the same step number as that of the previous step. |



| | |
|---|--|
| <p>5.A.R.W.No.</p> <div style="border: 1px solid black; padding: 5px; width: fit-content;"> PTN : 01 A . R . W . STEP 01 No. 1 </div> | <ol style="list-style-type: none"> ① Set ARWNo. For every pattern/step that is set. ② Set it from numbers 1 to 8. Number 0 can also be set and when it is set, a number same as that of the previous step is inherited. This is the function. |
| <p>6. Output limiter number and output variation limiter number</p> <div style="border: 1px solid black; padding: 5px; width: fit-content;"> PTN : 01 O P L.....No. 1 STEP 01 O S L.....No. 1 </div> <p>[Output scale specifications]</p> <div style="border: 1px solid black; padding: 5px; width: fit-content;"> PTN : 01 O P S.....No. 1 STEP 01 O S L.....No. 1 </div> <p>※Option</p> | <ol style="list-style-type: none"> ① Set output limiter number and output variation limiter number for each pattern/step that is set. ② Set anything from number 1 to 8 for both. Number 0 can also be set. When 0 is set, it becomes a function that inherits the same step number as that of the previous step. ③ In case of output scale specification (special specifications), the screen is, as shown on the lower left. |
| <p>7. Output preset No.</p> <div style="border: 1px solid black; padding: 5px; width: fit-content;"> PTN : 01 O U T P R E S E T STEP 01 No. 1 </div> | <ol style="list-style-type: none"> ① Set output preset number for every pattern/step. ② Set from numbers 1 to 8. Number 0 can also be set. When 0 is set, it becomes a function that inherits the same step number as that of the previous step. |
| <p>8. Sensor correction number</p> <div style="border: 1px solid black; padding: 5px; width: fit-content;"> PTN : 01 I N P U T S H I F T STEP 01 No. 1 </div> | <ol style="list-style-type: none"> ① Set sensor correction number for every pattern/step. ② Number 0 can also be set. When 0 is set, it becomes a function that inherits the same step number as that of the previous step. |
| <p>9. Time signal number</p> <div style="border: 1px solid black; padding: 5px; width: fit-content;"> PTN : 01 T I M E S I G N A L STEP 01 T S 1 No. O F F </div> | <ol style="list-style-type: none"> ① Only the specifications with external signal output (DO) are displayed. ② For every pattern/step that is set, time signal output destination and time signal number to be used is set. ③ Set time signal output destination in 'TS' and time signal number in 'No.'. ④ Set time signal number from number 1 to 8, number 1R-8R, ON and OFF. The 'R' after number is for repeating the time signal and only during that step, is a function where in time signal of that number repeats with identical setting value. 'ON' means everything ON and 'OFF' means everything OFF. |
| <p>10. Real temperature compensation number</p> <div style="border: 1px solid black; padding: 5px; width: fit-content;"> PTN : 01 G U A R A N . S O A K STEP 01 No. O F F </div> | <ol style="list-style-type: none"> ① Set real temperature compensation number for every pattern/step that is set. ② Set from number 1 to 8 and OFF. 'OFF' is a setting where in real temperature compensation does not operate. |

| | |
|--|---|
| <p>11. Waiting time alarm number</p> <div style="border: 1px solid black; padding: 5px; width: fit-content;"> PTN: 01 WAIT TIMER STEP 01 No. 1 </div> | <ol style="list-style-type: none"> ① Set waiting time alarm number for every pattern/step that is set. ② Number 0 can also be set. When 0 is set, it becomes a function that inherits the same step number as that of the previous step. |
| <p>12. Subsidiary output number</p> <div style="border: 1px solid black; padding: 5px; width: fit-content;"> PTN: 01 SUB OUT STEP 01 No. 1 </div> | <ol style="list-style-type: none"> ① It is displayed in specifications with transmission signal output when transmission type 'SUB' is selected. ② Set subsidiary output number for every pattern/step that is set. ③ Number 0 can also be set. When 0 is set, it becomes a function that inherits the same step number as that of the previous step. |
| <p>13. SV range</p> <div style="border: 1px solid black; padding: 5px; width: fit-content;"> SV LIMIT L - 0 2 0 0 . 0 H 1 3 7 0 . 0 </div> | <ol style="list-style-type: none"> ① Set SV setting range. ② Setting range is within the measurement scope (Including linear scale). ③ When measurement range, unit, measurement scope, linear scale etc is changed, sometimes setting range and decimal point position changes or initialization takes place automatically and relatively hence take care. |
| <p>14. Pattern repeat</p> <div style="border: 1px solid black; padding: 5px; width: fit-content;"> PATTERN REPEAT 0 0 0 0 </div> | <ol style="list-style-type: none"> ① Set pattern repeat (repeat). ② If you want to repeat the program pattern of same pattern number, it is a very convenient function. ③ When '0001' is set, same pattern is repeated once. Hence on a whole, the same pattern is run twice. 'Pattern repeat' is not only applicable to the executing pattern, but this set value is always enabled, hence take care. |
| <p>15. Clear pattern</p> <div style="border: 1px solid black; padding: 5px; width: fit-content;"> PATTERN CLEAR END EACH: 01 ALL </div> | <ol style="list-style-type: none"> ① It is a function that clears (deletes) the pattern that is set. ② When clearing the specified pattern number, set the pattern number that is to be cleared, on the right side of 'EACH:' and click the  key. ③ When clearing all the pattern numbers that are set, move the cursor to 'ALL' and click the  key. ④ When flashing is clear by clicking  key for while, and cursor return to "END", clear (delete) is executed. ⑤ Executing pattern cannot be cleared. ⑥ Cleared pattern number cannot be restored, hence take care. |
| <p>16. Copy pattern</p> <div style="border: 1px solid black; padding: 5px; width: fit-content;"> PATTERN COPY END PTN: 01 → 02 YES </div> | <ol style="list-style-type: none"> ① It is a function of copying the optional pattern number that is set, in pattern number which is not set. ② Set the pattern number of copy source on the left side of and pattern number of copy destination on the right side of '→', move the cursor to 'YES' and click  key. ③ Copy function cannot be performed on the pattern number that is set, hence if you want to copy on the pattern number that is already set, clear that pattern and then copy. |

| | |
|---|---|
| <p>17. SV at the time of resetting</p> <div style="border: 1px solid black; padding: 5px; width: fit-content; margin: 10px auto;"> PROGRAM RESET SV 0 0 0 0 . 0 </div> | <ol style="list-style-type: none"> ① It is displayed in case of specifications with transmission signal output or specifications with communication and when selecting [TRANS] function. ② Sets the SV at the time of resetting. ③ When selecting 'SV' by transmission type, the transmission value at the time of resetting becomes this setting value. |
| <p>18. Time unit</p> <div style="border: 1px solid black; padding: 5px; width: fit-content; margin: 10px auto;"> PROGRAM TIME UNIT HOUR : MIN MIN : SEC </div> | <ol style="list-style-type: none"> ① Set a common time unit related to program pattern, time signal and waiting time alarm. ② If 'HOUR:MIN' is selected it becomes hours and minutes. ③ If 'MIN:SEC' is selected, it becomes minutes and seconds. ④ This setting cannot be changed when the program is running. |

7-5. Mode 3

Mode 3 performs the setting related to PID and alarm.

| Settings screen | Description of the screen |
|---|--|
| <p>1. Mode screen</p> <div style="border: 1px solid black; padding: 5px; width: fit-content; margin: 10px auto;"> MODE 3 PID / ALARM </div> <p>[Lock Status]</p> <div style="border: 1px solid black; padding: 5px; width: fit-content; margin: 10px auto;"> MODE 3 Lock PID / ALARM </div> <p>[Display OFF status]</p> <div style="border: 1px solid black; padding: 5px; width: fit-content; margin: 10px auto;"> MODE 3 NoDisp PID / ALARM </div> | <ol style="list-style-type: none"> ① Mode 3 screen. ② By clicking the  ·  key, 'Lock' and 'No Disp' is displayed. ③ For mode 3 settings screen, if setting change is to be prohibited select 'Lock'. ④ When doing the settings by communications, set all the mode screens to 'Lock'. ⑤ When settings screen of mode 3 is not displayed, select 'NoDisp'. |
| <p>2. 16 types PID</p> <div style="border: 1px solid black; padding: 5px; width: fit-content; margin: 10px auto;"> PID No. 1 P : 0 0 5 . 0 % I : 0 0 6 0 s D : 0 0 3 0 s </div> | <ol style="list-style-type: none"> ① Set all 16 types of PID from 1-8 and from 9-1 to 9-8. ② Numbers 9-1 to 9-8 correspond to automatic PID switching system. ③ By setting P to 0%, it becomes two-position control operation. ④ If I is set to 0s, it is equivalent to ∞ and if D is set to 0s, it is equivalent to OFF. ⑤ After the settings, it is necessary to set the PID number that is to be used for each pattern/step in mode 2. |

| | |
|---|--|
| <p>3. 8 types A.R.W.</p> <div style="border: 1px solid black; padding: 5px; width: fit-content; margin: 10px auto;"> <p style="text-align: center;">A . R . W . No. 1</p> <p style="text-align: center;">L - 0 5 0 . 0 % H 0 5 0 . 0 %</p> </div> | <ul style="list-style-type: none"> ① Set 8 types of ARW (Anti reset windup). ② For PID control, it is a function for deciding the range of PID operation. If this setting value is exceeded, it becomes a PD operation. ③ Setting value is percentage (%) of measurement scope (including linear scale). ④ This function works only for position type PID control. |
| <p>4. Output 2 PID</p> <div style="border: 1px solid black; padding: 5px; width: fit-content; margin: 10px auto;"> <p style="text-align: center;">O U T 2 P I D P : 0 0 5 . 0 %</p> <p style="text-align: center;">I : 0 0 6 0 s D : 0 0 3 0 s</p> </div> | <ul style="list-style-type: none"> ① Output 2 specifications and output 2 control are displayed only when 'PID system' is selected. ② Set the PID for output 2. ③ By setting P to 0%, it becomes two-position control operation. ④ If I is set to 0s, it is equivalent to ∞ and if D is set to 0s, it is equivalent to OFF. |
| <p>5. Output 2 gap</p> <div style="border: 1px solid black; padding: 5px; width: fit-content; margin: 10px auto;"> <p style="text-align: center;">O U T 1 - O U T 2 G A P</p> <p style="text-align: center;">0 0 0 . 0 %</p> </div> | <ul style="list-style-type: none"> ① Output 2 specifications and output 2 control system is displayed only when 'PID system' is selected. ② Set the gap between output 1 and output 2. |
| <p>6. Output dead band</p> <div style="border: 1px solid black; padding: 5px; width: fit-content; margin: 10px auto;"> <p style="text-align: center;">P I D D . B A N D 0 . 0 %</p> <p style="text-align: center;">P = 0 D . B A N D 0 . 5 %</p> </div> | <ul style="list-style-type: none"> ① Set output dead band. ② Set PID dead band in 'PID D.BAND' of the upper row and output dead band of two position control operation (When P=0%) in 'P=0 D.BAND' on the lower row respectively. ③ PID dead band non-linearises the deviation in the dead band and slows down the response of control output. ④ Output dead band of two position operation control action becomes the dead band at the time of output ON/OFF. |
| <p>7. Output 2 dead band</p> <div style="border: 1px solid black; padding: 5px; width: fit-content; margin: 10px auto;"> <p style="text-align: center;">O U T 2 D . B A N D 0 . 0 %</p> <p style="text-align: center;">P = 0 D . B A N D 0 . 5 %</p> </div> | <ul style="list-style-type: none"> ① Output 2 specifications and output 2 control system are displayed only when 'PID system' is selected. ② Set output dead band for output 2. ③ Set PID dead band in 'D.BAND' of upper row, and output dead band of two position control action (When P=0%). in 'P=0 D.BAND' of lower row respectively. ④ PID dead band non-linearises the deviation in dead band and slows the response of control output. ⑤ Output dead band of two-position control action becomes a dead band at the time of output ON/OFF. |



| | | | | | |
|--|--|--|---|--|---|
| <p>8. Alarm format of alarm 1 and alarm 2</p> <div style="border: 1px solid black; padding: 5px; width: fit-content; margin: 10px auto;"> ALARM AL1 : DV - H MODE AL2 : DV - H </div> | <p>① Sets alarm format of alarm 1 (AL1) and alarm 2 (AL2). ② There are various alarm formats as follows, set them on the left side of the hyphen (-). Respectively for that, set the higher limit/lower limit, wait no/wait yes, maintenance no/maintenance yes on the right side of the hyphen (-).</p> <table style="width: 100%; border: none;"> <tr> <td style="width: 50%; vertical-align: top;"> [Left side of the hyphen] ·PV : Absolute value alarm ·DV : Deviation alarm ·ADV : Absolute value deviation alarm ·SV : Setting value alarm ·MV : Output value alarm </td> <td style="width: 50%; vertical-align: top;"> [Right side of the hyphen] ·H : Higher limit alarm ·L : Lower limit alarm ·HW : Wait yes higher limit alarm ·LW : Wait yes lower limit alarm ·HK : Maintenance yes higher limit alarm ·LK : Maintenance yes lower limit alarm ·HWK: Wait yes, maintenance yes higher limit alarm ·LWK : Wait yes, maintenance yes lower limit alarm </td> </tr> </table> <p>Other than these, the following format can also be set according to the specifications.</p> <table style="width: 100%; border: none;"> <tr> <td style="width: 50%;"> ·CT : Heater snapping wire alarm ·TIMER : Timer ·FAIL : Fail alarm ·WAIT : Waiting time alarm </td> <td style="width: 50%; vertical-align: top;"> × Restricted to specifications with heater snapping wire alarm. × Restricted to specifications with external signal input. </td> </tr> </table> | [Left side of the hyphen] ·PV : Absolute value alarm ·DV : Deviation alarm ·ADV : Absolute value deviation alarm ·SV : Setting value alarm ·MV : Output value alarm | [Right side of the hyphen] ·H : Higher limit alarm ·L : Lower limit alarm ·HW : Wait yes higher limit alarm ·LW : Wait yes lower limit alarm ·HK : Maintenance yes higher limit alarm ·LK : Maintenance yes lower limit alarm ·HWK: Wait yes, maintenance yes higher limit alarm ·LWK : Wait yes, maintenance yes lower limit alarm | ·CT : Heater snapping wire alarm ·TIMER : Timer ·FAIL : Fail alarm ·WAIT : Waiting time alarm | × Restricted to specifications with heater snapping wire alarm. × Restricted to specifications with external signal input. |
| [Left side of the hyphen] ·PV : Absolute value alarm ·DV : Deviation alarm ·ADV : Absolute value deviation alarm ·SV : Setting value alarm ·MV : Output value alarm | [Right side of the hyphen] ·H : Higher limit alarm ·L : Lower limit alarm ·HW : Wait yes higher limit alarm ·LW : Wait yes lower limit alarm ·HK : Maintenance yes higher limit alarm ·LK : Maintenance yes lower limit alarm ·HWK: Wait yes, maintenance yes higher limit alarm ·LWK : Wait yes, maintenance yes lower limit alarm | | | | |
| ·CT : Heater snapping wire alarm ·TIMER : Timer ·FAIL : Fail alarm ·WAIT : Waiting time alarm | × Restricted to specifications with heater snapping wire alarm. × Restricted to specifications with external signal input. | | | | |
| <p>9. Alarm format of alarm 3 and alarm 4</p> <div style="border: 1px solid black; padding: 5px; width: fit-content; margin: 10px auto;"> ALARM AL3 : DV - H MODE AL4 : DV - H </div> | <p>① Sets alarm format of alarm 3 (AL3) and alarm 4 (AL4). ② There are various alarm formats as follows, set them on the left side of the hyphen (-). Respectively for that, set the higher limit/lower limit, wait no/wait yes, maintenance no/maintenance yes on the right side of the hyphen (-).</p> <table style="width: 100%; border: none;"> <tr> <td style="width: 50%; vertical-align: top;"> [Left side of the hyphen] ·PV : Absolute value alarm ·DV : Deviation alarm ·ADV : Absolute value deviation alarm ·SV : Setting value alarm ·MV : Output value alarm </td> <td style="width: 50%; vertical-align: top;"> [Right side of the hyphen] ·H : Higher limit alarm ·L : Lower limit alarm ·HW : Wait yes higher limit alarm ·LW : Wait yes lower limit alarm ·HK : Maintenance yes higher limit alarm ·LK : Maintenance yes lower limit alarm ·HWK: Wait yes, maintenance yes higher limit alarm ·LWK : Wait yes, maintenance yes lower limit alarm </td> </tr> </table> <p>Other than these, the following format can also be set according to the specifications.</p> <table style="width: 100%; border: none;"> <tr> <td style="width: 50%;"> ·CT : Heater snapping wire alarm ·TIMER : Timer ·FAIL : Fail alarm ·WAIT : Waiting time alarm </td> <td style="width: 50%; vertical-align: top;"> × Restricted to specifications with heater snapping wire alarm. × Restricted to specifications with external signal input. </td> </tr> </table> | [Left side of the hyphen] ·PV : Absolute value alarm ·DV : Deviation alarm ·ADV : Absolute value deviation alarm ·SV : Setting value alarm ·MV : Output value alarm | [Right side of the hyphen] ·H : Higher limit alarm ·L : Lower limit alarm ·HW : Wait yes higher limit alarm ·LW : Wait yes lower limit alarm ·HK : Maintenance yes higher limit alarm ·LK : Maintenance yes lower limit alarm ·HWK: Wait yes, maintenance yes higher limit alarm ·LWK : Wait yes, maintenance yes lower limit alarm | ·CT : Heater snapping wire alarm ·TIMER : Timer ·FAIL : Fail alarm ·WAIT : Waiting time alarm | × Restricted to specifications with heater snapping wire alarm. × Restricted to specifications with external signal input. |
| [Left side of the hyphen] ·PV : Absolute value alarm ·DV : Deviation alarm ·ADV : Absolute value deviation alarm ·SV : Setting value alarm ·MV : Output value alarm | [Right side of the hyphen] ·H : Higher limit alarm ·L : Lower limit alarm ·HW : Wait yes higher limit alarm ·LW : Wait yes lower limit alarm ·HK : Maintenance yes higher limit alarm ·LK : Maintenance yes lower limit alarm ·HWK: Wait yes, maintenance yes higher limit alarm ·LWK : Wait yes, maintenance yes lower limit alarm | | | | |
| ·CT : Heater snapping wire alarm ·TIMER : Timer ·FAIL : Fail alarm ·WAIT : Waiting time alarm | × Restricted to specifications with heater snapping wire alarm. × Restricted to specifications with external signal input. | | | | |
| <p>10. Alarm 1 and Alarm 2 8 types</p> <div style="border: 1px solid black; padding: 5px; width: fit-content; margin: 10px auto;"> ALARM AL1 / AL2 No. 1 3000.0 / -1999.9 </div> | <p>① Set 8 types of settings values of alarm 1 and alarm 2. ② When FAIL is selected in alarm format, 'FAIL' is displayed and when WAIT is selected, 'WAIT' is displayed, and settings cannot be done. ③ It is necessary to set the alarm number that is to be used for each pattern/step in mode 2 after the settings. ④ When measurement range, unit, measurement scope, linear scale, alarm format etc is changed, sometimes setting range and decimal point position changes automatically and relatively hence take care.</p> | | | | |

| | |
|---|---|
| <p>11. Alarm 3 and Alarm 4 8 types</p> <div style="border: 1px solid black; padding: 5px; width: fit-content; margin: 10px auto;"> ALARM AL3/AL4 No. 1 3000.0 / -1999.9 </div> | <ol style="list-style-type: none"> ① Set 8 types of settings values of alarm 3 and alarm 4. ② When FAIL is selected in alarm format, 'FAIL' is displayed and when WAIT is selected, 'WAIT' is displayed, and settings cannot be done. ③ It is necessary to set the alarm number that is to be used for each pattern/step in mode 2 after the settings. ④ When measurement range, unit, measurement scope, linear scale, alarm format etc is changed, sometimes setting range and decimal point position changes automatically and relatively hence take care. |
| <p>12. Alarm dead band</p> <div style="border: 1px solid black; padding: 5px; width: fit-content; margin: 10px auto;"> ALARM D. BAND AL1 002.00 </div> | <ol style="list-style-type: none"> ① Set alarm dead band of alarms 1 to 4. ② Unit is the same as the setting value of respective alarm. ③ When alarm format is TIMER, FAIL, and WAIT, this setting value is disabled. ④ When measurement range, unit, measurement scope, linear scale, alarm format etc is changed, sometimes decimal point position changes automatically and relatively hence take care. |
| <p>13. Alarm delay</p> <div style="border: 1px solid black; padding: 5px; width: fit-content; margin: 10px auto;"> ALARM ON DELAY 0000.0s </div> | <ol style="list-style-type: none"> ① Set the delay time of alarm. ② If the judgment time of alarm ON is continuously greater than or equal to the setting value, the alarm turns ON in the beginning. If the judgment time of alarm ON is less than the setting value, alarm does not turn ON. ③ When alarm format is TIMER, FAIL, and WAIT, this setting value becomes disabled. ④ Take care as the setting value is common for alarm of all the 4 points. |
| <p>14. SV 8 types for AT2</p> <div style="border: 1px solid black; padding: 5px; width: fit-content; margin: 10px auto;"> AUTO TUNING 2 SV1 ON 0000.0 </div> | <ol style="list-style-type: none"> ① Set 8 types of SV for auto tuning AT2. ② Auto tuning can be set to ON (execute)/OFF (do not execute) for 8 types separately. ③ Setting range is within the measurement scope (including linear scale). ④ PID calculated using SV numbers from 1 to 8 for AT2, correspond to execution numbers 1 to 8 and are registered in PID numbers 1 to 8. ⑤ When measurement range, unit, measurement scope, linear scale etc is changed, sometimes the setting range and decimal point position changes or initialization takes place automatically and relatively hence take care. |
| <p>15. SV section for automatic PID</p> <div style="border: 1px solid black; padding: 5px; width: fit-content; margin: 10px auto;"> SV SCOPE PID No. 9-1 -0200.0 ~ -0003.8 </div> | <ol style="list-style-type: none"> ① Set 8 types of SV sections in automatic PID conversion system. ② Setting range is within the measurement scope (including linear scale). Duplicate SV section cannot be set. ③ When measurement range, unit, measurement scope, linear scale etc is changed, sometimes the setting range and decimal point position changes or initialization takes place automatically and relatively hence take care. |

| | |
|--|---|
| <p>16. SV 8 types for AT3</p> <div style="border: 1px solid black; padding: 5px; width: fit-content; margin: 10px auto;"> <p>AUTO TUNING 3 SV1 OFF -0101.9</p> </div> | <ul style="list-style-type: none"> ① Set 8 types of SV for auto tuning AT3. ② Auto tuning can be set to ON (execute)/OFF (do not execute) for 8 types separately. ③ Setting range is within the range of SV section number of equivalent automatic PID conversion system. ④ PID calculated using SV numbers 1 to 8 for AT3 are registered in PID numbers from 9-1 to 9-8. ⑤ When measurement range, unit, measurement scope, linear scale etc is changed, sometimes the setting range and decimal point position changes or initialization takes place automatically and relatively hence take care. |
| <p>17. AT2, AT3</p> <p>Start direction</p> <div style="border: 1px solid black; padding: 5px; width: fit-content; margin: 10px auto;"> <p>AT2/AT3 START UP DOWN</p> </div> | <ul style="list-style-type: none"> ① Set execution direction at the time of executing auto tuning AT2 or AT3. ② If 'UP' is selected, auto tuning progresses from SV1 to SV8. ③ If 'DOWN' is selected, auto tuning progresses from SV8 to SV1. |
| <p>18. Control algorithm</p> <div style="border: 1px solid black; padding: 5px; width: fit-content; margin: 10px auto;"> <p>PID TYPE POSITION/VELOCITY</p> </div> | <ul style="list-style-type: none"> ① Set control algorithm. ② If 'POSITION' is selected, it is position type PID system. ③ If 'VELOCITY' is selected, it is speed type PID system. |

7-6. Mode 4

Mode 4 performs the setting related to output.

| Settings screen | Description of the screen |
|---|---|
| <p>1. Mode screen</p> <div style="border: 1px solid black; padding: 5px; width: fit-content; margin: 5px 0;"> MODE 4 OUTPUT SET </div> <p>[Lock Status]</p> <div style="border: 1px solid black; padding: 5px; width: fit-content; margin: 5px 0;"> MODE 4 Lock OUTPUT SET </div> <p>[Display OFF status]</p> <div style="border: 1px solid black; padding: 5px; width: fit-content; margin: 5px 0;"> MODE 4 NoDisp OUTPUT SET </div> | <ul style="list-style-type: none"> ① Mode 4 screen. ② By clicking the · key, 'Lock' and 'NoDisp' is displayed. ③ For mode 4 settings screen, if setting change is to be prohibited select 'Lock'. ④ When doing the settings by communications, set all the mode screens to 'Lock'. ⑤ When settings screen of mode 4 is not displayed, select 'NoDisp'. |
| <p>2. Output limiter 8 types</p> <div style="border: 1px solid black; padding: 5px; width: fit-content; margin: 5px 0;"> OUTPUT LIMIT No. 1 L: 000.0% H: 100.0% </div> <p>[Output scale specifications]</p> <div style="border: 1px solid black; padding: 5px; width: fit-content; margin: 5px 0;"> OUTPUT SCALE No. 1 L: 000.0% H: 100.0% </div> <p>※ Option</p> | <ul style="list-style-type: none"> ① Set 8 types of output limiters. ② Set lower limit of output limiter in 'L' , and upper limit of output limiter in 'H'. ③ In either of automatic output operation and manual output operation the output is within this setting range. ④ In case of output scale specifications (option) instead of output limiter, the screen is as shown on the lower left. ⑤ After the settings, it is necessary to set the output limiter number that is to be used for each pattern/step in mode 2. |
| <p>3. Output 2 limiter</p> <div style="border: 1px solid black; padding: 5px; width: fit-content; margin: 5px 0;"> OUT2 OUTPUT LIMIT L: 000.0% H: 100.0% </div> <p>[Output scale specifications]</p> <div style="border: 1px solid black; padding: 5px; width: fit-content; margin: 5px 0;"> OUT2 OUTPUT SCALE L: 000.0% H: 100.0% </div> <p>※ Option</p> | <ul style="list-style-type: none"> ① It is displayed in case of output 2 specifications only. ② Set the output limiter of output 2 side. ③ Set lower limit of output limiter in 'L' , and upper limit of output limiter in 'H'. ④ In either of automatic output operation and manual output operation the output is within this setting range. ⑤ In case of output scale specifications (option) instead of output limiter specifications, the screen is as shown on the lower left. |



| | |
|--|--|
| <p>4. Output variation limiter 8 types</p> <div style="border: 1px solid black; padding: 5px; width: fit-content; margin: 10px auto;"> O S L UP/DOWN No. 1 1 0 0 . 0 % / - 1 0 0 . 0 % </div> | <ol style="list-style-type: none"> ① Set 8 types of output variation limiters. ② On the lower left, output variation limiter at the time of ascending output and on the lower right, output variation limiter at the time of descending output are displayed. ③ After the settings, it is necessary to set the output variation limiter number that is to be used for each pattern/step in mode 2. ④ In case of specifications with external signal input and in case of external signal layout 'Preset manual' layout, numbers up to No. 9 are displayed and in No. 9, variation limiter of MV (output value) at the time of switching from automatic output operation to output preset operation is set. |
| <p>5. Output 2 variation limiter</p> <div style="border: 1px solid black; padding: 5px; width: fit-content; margin: 10px auto;"> O U T 2 O S L UP/DOWN 1 0 0 . 0 % / - 1 0 0 . 0 % </div> | <ol style="list-style-type: none"> ① It is displayed only in case of output 2 specifications. ② Set output variation limiter of output 2 side. ③ On the lower left, output variation limiter at the time of ascending output and on the lower right, output variation limiter at the time of descending output are displayed. |
| <p>6. Output during program end</p> <div style="border: 1px solid black; padding: 5px; width: fit-content; margin: 10px auto;"> P R O G R A M E N D O U T P T N : 0 1 C O N T R O L </div> <p>[Output 2 specifications]</p> <div style="border: 1px solid black; padding: 5px; width: fit-content; margin: 10px auto;"> E N D O U T 1 / 2 P T N : 0 1 C O N T R O L / C O N T R O L </div> | <ol style="list-style-type: none"> ① Sets the output value (MV) at the time of program end (END). ② If 'CONTROL' is selected, automatic output operation (or manual output operation) continues in final SV, until resetting (RESET) is done. ③ If output value is set directly, that output value continues until resetting (RESET) is done. ④ Output range is within the output limiter range. ⑤ Set it for each pattern number. |
| <p>7. Output preset 8 types</p> <div style="border: 1px solid black; padding: 5px; width: fit-content; margin: 10px auto;"> O U T P U T P R E S E T N o . 1 0 5 0 . 0 % </div> | <ol style="list-style-type: none"> ① Set 8 types of output presets. ② Output range is within output limiter range. ③ It is necessary to set whether to use it or not for every pattern/step in mode 2 after the settings. |
| <p>8. Pulse cycle</p> <div style="border: 1px solid black; padding: 5px; width: fit-content; margin: 10px auto;"> P U L S E C Y C L E 0 3 0 s </div> <p>[Output 2 specifications]</p> <div style="border: 1px solid black; padding: 5px; width: fit-content; margin: 10px auto;"> P U L S E C Y C L E O U T 1 / 2 0 3 0 s / 0 3 0 s </div> | <ol style="list-style-type: none"> ① ON-OFF pulse type or SSR drive pulse type only is displayed. ② Set time for one cycle of output ON/OFF. ③ In output 2 specifications, do the respective settings in case of output 2 and pulse type. ④ When setting value is changed, after end of one cycle before the setting value that is changed, do the operation using the setting value after the changed settings. ⑤ Generally set the highest value as far as possible that is within the range and that does not adversely affect the controllability. |

| | |
|--|--|
| <p>9. FB tuning</p> <div style="border: 1px solid black; padding: 5px; width: fit-content; margin: 10px auto;"> <p>F. B. A U T O T U N I N G E N D S T A R T</p> </div> | <ul style="list-style-type: none"> ① ON-OFF servo type only is displayed. ② This function is a function that automatically requests the setting value of FB zero span of this controller and the operation terminal (motor etc.) ③ When FB tuning is started, AT progress status (START, CLOSE, TUNE-ZERO, OPEN, TUNE-SPAN) is displayed. ④ If you want to stop FB tuning in between, set 'END'. ⑤ FB zero span requested in FB tuning, can be confirmed by 'FB zero span' of mode 4. |
| <p>10. FB zero span</p> <div style="border: 1px solid black; padding: 5px; width: fit-content; margin: 10px auto;"> <p>F. B. Z E R O / S P A N Z : 0 0 . 0 % S : 1 0 0 . 0 %</p> </div> | <ul style="list-style-type: none"> ① ON-OFF servo type only is displayed. ② Set the FB zero span of this controller and operation terminal (motor etc.). ③ Set zero value in 'Z' and span value in 'S'. |
| <p>11. FB dead band</p> <div style="border: 1px solid black; padding: 5px; width: fit-content; margin: 10px auto;"> <p>F. B. D. B A N D 1. 0 %</p> </div> | <ul style="list-style-type: none"> ① ON-OFF servo type only is displayed. ② Set FB gain (dead band). ③ Generally, set a value as large as possible and within the scope such that it does not adversely affect the controllability. This setting value is not an accurate percentage (%) value, hence as far as possible take it as a reference. |
| <p>12. Output at the time of PV abnormality</p> <div style="border: 1px solid black; padding: 5px; width: fit-content; margin: 10px auto;"> <p>P V E R R O V R : 0 0 0 . 0 % O U T U D R : 0 0 0 . 0 %</p> </div> | <ul style="list-style-type: none"> ① Output value at the time of PV abnormality is set. ② Set respectively the output value in 'OVR' when PV exceeds the range (including higher limit burnout) and set the value in 'UDR' when PV is below the range (including lower limit burnout). ③ Output range is within the output limiter range. |
| <p>13. Output at the time of output 2 PV abnormality</p> <div style="border: 1px solid black; padding: 5px; width: fit-content; margin: 10px auto;"> <p>P V E R R O V R : 0 0 0 . 0 % O U T 2 U D R : 0 0 0 . 0 %</p> </div> | <ul style="list-style-type: none"> ① It is displayed only in case of output 2 specifications. ② Set the output value at the time of PV abnormality of output 2 side. ③ Set respectively the output value in 'OVR' when PV exceeds the range (including higher limit burnout) and set the value in 'UDR' when PV is below the range (including lower limit burnout). ④ Output range is within the range of output 2 limiter. |

| | |
|---|--|
| <p>14. Direct/Reverse control operation</p> <div style="border: 1px solid black; padding: 5px; text-align: center;"> OUTPUT MODE DIRECT REVERSE </div> <p>[Output 2 specifications]</p> <div style="border: 1px solid black; padding: 5px; text-align: center;"> OUTPUT MODE OUT1/2 REVERSE / DIRECT </div> | <ol style="list-style-type: none"> ① Set control operation. ② If 'DIRECT' is selected, it becomes a direct operation (Cooling operation). ③ If 'REVERSE' is selected, it becomes a reverse operation (heating operation). ④ For output 2 specifications, see the screen on lower left, on the left of '/' is the control action of output 1 and on the right is the control action of output 2. Set each of them separately. |
| <p>15. Preset manual</p> <div style="border: 1px solid black; padding: 5px; text-align: center;"> PRESET MANUAL OUT 000.0% </div> <p>[Output 2 specifications]</p> <div style="border: 1px solid black; padding: 5px; text-align: center;"> PRESET MANU OUT1/2 000.0% / 000.0% </div> | <ol style="list-style-type: none"> ① Displayed only in case of specifications with external signal input (DI) and in case of 'Preset manual' layout in external signal input layout. ② Set preset manual. ③ When preset manual is ON in external signal input, output value becomes the setting value. ④ Output range is within the output limiter range. ⑤ In case of output 2 specifications, the screen is as shown on the lower left and each setting is done separately. |
| <p>16. Output 2 control system</p> <div style="border: 1px solid black; padding: 5px; text-align: center;"> OUT2 CONTROL TYPE PID SPRIT </div> | <ol style="list-style-type: none"> ① It is displayed only in case of output 2 specifications. ② Selects control type of output 2 specifications. ③ When 'PID' is selected, the type is PID control type. ④ When 'SPRIT' is selected, the type is SPRIT control type. |
| <p>17.SPRIT</p> <div style="border: 1px solid black; padding: 5px; text-align: center;"> SPRIT DIR: 0.0% REV:100.0% </div> | <ol style="list-style-type: none"> ① In case of output 2 specifications, output 2 control specifications are displayed only when 'SPRIT' is selected. ② Set direct value in 'DIR' and reverse value in 'REV'. |

7-7. Mode 5

Mode 5 performs the setting related to input.

| Settings screen | Description of the screen | | | | | | | | | | | | | | | | | | | | | | | | | | | | | | | | | | | | | | | | | | | | | | | | | | | | | | | | | | | | | | | | | | | | | | | | | | | | | | | | | | | | | | | | | | | | | | | | | | | | | | | | | | | | | | | | | | | | | | | | | | | | | | | | | | | | | | | | | | | | | | | | | | | | | | | | | | | | | | | | | |
|--|--|-------------------|------------------|-------------------|---------------------|------------------|-------------------|-------------------|-------------------------|-----------------|--------------|-----------------|-----------------|----|--------------|---------|---------------|----|-------------------------|------|-----------|----|----|---------------|----|---------|---------------|----|----|---------------|----|---------|-----------------|----|---|---------------|----|---------|----------------|----|------------------------|----------|-----------------|----|----|------------------|----|---|---------------|----|----------|-----------------|----|----|--------------|----|--------|---------------|----|----------|-----------------|----|----|-----------------|----|-----------|---------------|----|----------|-----------------|----|----|------------------|----|------------|---------------|----|----------|-----------------|----|----|--------------|----|------------|--------------|----|----------|-----------------|----|----|-----------------|----|---|-----------------|----|----------|-----------------|----|----|-----------------|----|---|-----------------|----|----------|-----------------|----|----|------------------|----|---------------------|------|-------|----|--------|-----------------|----|----|-----------------|----|------|-------|----|---------|-----------------|----|----|-----------------|----|------|-------|----|---------|-----------------|----|----|-----------------|----|-------|--------|----|---------|-----------------|----|----|-----------------|----|----|-----|----|---------|-----------------|----|----|-----------------|----|-----|------|--|--|--|--|
| <p>1. Mode screen</p> <div style="border: 1px solid black; padding: 5px; margin: 5px 0;"> MODE <u>5</u> INPUT SET </div> <p>[Lock Status]</p> <div style="border: 1px solid black; padding: 5px; margin: 5px 0;"> MODE <u>5</u> Lock INPUT SET </div> <p>[Display OFF status]</p> <div style="border: 1px solid black; padding: 5px; margin: 5px 0;"> MODE <u>5</u> NoDisp INPUT SET </div> | <p>① Mode 5 screen.</p> <p>② By clicking the · key, 'Lock' and 'NoDisp' is displayed.</p> <p>③ For mode 5 settings screen, if setting change is to be prohibited select 'Lock'.</p> <p>④ When doing the settings by communications, set all the mode screens to 'Lock'.</p> <p>⑤ When settings screen of mode 5 is not displayed, select 'NoDisp'.</p> | | | | | | | | | | | | | | | | | | | | | | | | | | | | | | | | | | | | | | | | | | | | | | | | | | | | | | | | | | | | | | | | | | | | | | | | | | | | | | | | | | | | | | | | | | | | | | | | | | | | | | | | | | | | | | | | | | | | | | | | | | | | | | | | | | | | | | | | | | | | | | | | | | | | | | | | | | | | | | | | | |
| <p>2. Measurement range</p> <div style="border: 1px solid black; padding: 5px; margin: 5px 0;"> INPUT KIND 0 5 K 1 </div> | <p>① Set the measurement range.</p> <p>② Types of measurement ranges are as shown in the table below.</p> <p>③ It differs depending on the measurement range, however it exceeds the higher limit value of the scale range by approximately +5% and is below the range by approximately -5%.</p> <p>④ When measurement range is changed, sometimes the setting range and decimal point position changes or initialization takes place automatically and relatively hence take care.</p> | | | | | | | | | | | | | | | | | | | | | | | | | | | | | | | | | | | | | | | | | | | | | | | | | | | | | | | | | | | | | | | | | | | | | | | | | | | | | | | | | | | | | | | | | | | | | | | | | | | | | | | | | | | | | | | | | | | | | | | | | | | | | | | | | | | | | | | | | | | | | | | | | | | | | | | | | | | | | | | | | |
| [Universal] | | | | | | | | | | | | | | | | | | | | | | | | | | | | | | | | | | | | | | | | | | | | | | | | | | | | | | | | | | | | | | | | | | | | | | | | | | | | | | | | | | | | | | | | | | | | | | | | | | | | | | | | | | | | | | | | | | | | | | | | | | | | | | | | | | | | | | | | | | | | | | | | | | | | | | | | | | | | | | | | | | |
| <table border="1"> <thead> <tr> <th>No.</th> <th>Measurement range</th> <th>Scale range (°C)</th> <th>No.</th> <th>Measurement range</th> <th>Scale range (°C)</th> <th>No.</th> <th>Measurement range</th> <th>Scale range (°C)</th> </tr> </thead> <tbody> <tr> <td>01</td> <td rowspan="17">Thermocouple</td> <td>B</td> <td>0.0 to 1820.0</td> <td>18</td> <td rowspan="10">Thermocouple</td> <td>WRe5-26</td> <td>0.0 to 2310.0</td> <td rowspan="3">36</td> <td rowspan="3">Direct current (Linear)</td> <td rowspan="3">20mA</td> <td rowspan="3">0 to 20mA</td> </tr> <tr> <td>02</td> <td>R1</td> <td>0.0 to 1760.0</td> <td>19</td> <td>W-WRe26</td> <td>0.0 to 2310.0</td> </tr> <tr> <td>03</td> <td>R2</td> <td>0.0 to 1200.0</td> <td>20</td> <td>NiMo-Ni</td> <td>-50.0 to 1410.0</td> </tr> <tr> <td>04</td> <td>S</td> <td>0.0 to 1760.0</td> <td>21</td> <td>CR-AuFe</td> <td>0.0 to 280.0 K</td> <td rowspan="7">41</td> <td rowspan="7">Resistance thermometer</td> <td>JPt100Ω1</td> <td>-200.0 to 649.0</td> </tr> <tr> <td>05</td> <td>K1</td> <td>-200.0 to 1370.0</td> <td>22</td> <td>N</td> <td>0.0 to 1300.0</td> <td>42</td> <td>JPt100Ω2</td> <td>-200.0 to 400.0</td> </tr> <tr> <td>06</td> <td>K2</td> <td>0.0 to 600.0</td> <td>23</td> <td>PR5-20</td> <td>0.0 to 1800.0</td> <td>44</td> <td>JPt100Ω4</td> <td>-200.0 to 200.0</td> </tr> <tr> <td>07</td> <td>K3</td> <td>-200.0 to 300.0</td> <td>24</td> <td>PtRh40-20</td> <td>0.0 to 1880.0</td> <td>45</td> <td>JPt100Ω5</td> <td>-100.0 to 100.0</td> </tr> <tr> <td>08</td> <td>E1</td> <td>-270.0 to 1000.0</td> <td>25</td> <td>Plati II 1</td> <td>0.0 to 1390.0</td> <td>46</td> <td>QPt100Ω1</td> <td>-200.0 to 649.0</td> </tr> <tr> <td>09</td> <td>E2</td> <td>0.0 to 700.0</td> <td>26</td> <td>Plati II 2</td> <td>0.0 to 600.0</td> <td>47</td> <td>QPt100Ω2</td> <td>-200.0 to 400.0</td> </tr> <tr> <td>10</td> <td>E3</td> <td>-270.0 to 300.0</td> <td>27</td> <td>U</td> <td>-200.0 to 400.0</td> <td>49</td> <td>QPt100Ω4</td> <td>-200.0 to 200.0</td> </tr> <tr> <td>11</td> <td>E4</td> <td>-270.0 to 150.0</td> <td>28</td> <td>L</td> <td>-200.0 to 900.0</td> <td>50</td> <td>QPt100Ω5</td> <td>-100.0 to 100.0</td> </tr> <tr> <td>12</td> <td>J1</td> <td>-200.0 to 1200.0</td> <td>31</td> <td rowspan="7">DC voltage (Linear)</td> <td>10mV</td> <td>±10mV</td> <td>51</td> <td>JPt50Ω</td> <td>-200.0 to 649.0</td> </tr> <tr> <td>13</td> <td>J2</td> <td>-200.0 to 900.0</td> <td>32</td> <td>20mV</td> <td>±20mV</td> <td>53</td> <td>Pt100Ω1</td> <td>-200.0 to 850.0</td> </tr> <tr> <td>14</td> <td>J3</td> <td>-200.0 to 400.0</td> <td>33</td> <td>50mV</td> <td>±50mV</td> <td>54</td> <td>Pt100Ω2</td> <td>-200.0 to 400.0</td> </tr> <tr> <td>15</td> <td>J4</td> <td>-100.0 to 200.0</td> <td>34</td> <td>100mV</td> <td>±100mV</td> <td>56</td> <td>Pt100Ω4</td> <td>-200.0 to 200.0</td> </tr> <tr> <td>16</td> <td>T1</td> <td>-270.0 to 400.0</td> <td>35</td> <td>5V</td> <td>±5V</td> <td>57</td> <td>Pt100Ω5</td> <td>-100.0 to 100.0</td> </tr> <tr> <td>17</td> <td>T2</td> <td>-200.0 to 200.0</td> <td>37</td> <td>10V</td> <td>±10V</td> <td></td> <td></td> <td></td> </tr> </tbody> </table> | No. | Measurement range | Scale range (°C) | No. | Measurement range | Scale range (°C) | No. | Measurement range | Scale range (°C) | 01 | Thermocouple | B | 0.0 to 1820.0 | 18 | Thermocouple | WRe5-26 | 0.0 to 2310.0 | 36 | Direct current (Linear) | 20mA | 0 to 20mA | 02 | R1 | 0.0 to 1760.0 | 19 | W-WRe26 | 0.0 to 2310.0 | 03 | R2 | 0.0 to 1200.0 | 20 | NiMo-Ni | -50.0 to 1410.0 | 04 | S | 0.0 to 1760.0 | 21 | CR-AuFe | 0.0 to 280.0 K | 41 | Resistance thermometer | JPt100Ω1 | -200.0 to 649.0 | 05 | K1 | -200.0 to 1370.0 | 22 | N | 0.0 to 1300.0 | 42 | JPt100Ω2 | -200.0 to 400.0 | 06 | K2 | 0.0 to 600.0 | 23 | PR5-20 | 0.0 to 1800.0 | 44 | JPt100Ω4 | -200.0 to 200.0 | 07 | K3 | -200.0 to 300.0 | 24 | PtRh40-20 | 0.0 to 1880.0 | 45 | JPt100Ω5 | -100.0 to 100.0 | 08 | E1 | -270.0 to 1000.0 | 25 | Plati II 1 | 0.0 to 1390.0 | 46 | QPt100Ω1 | -200.0 to 649.0 | 09 | E2 | 0.0 to 700.0 | 26 | Plati II 2 | 0.0 to 600.0 | 47 | QPt100Ω2 | -200.0 to 400.0 | 10 | E3 | -270.0 to 300.0 | 27 | U | -200.0 to 400.0 | 49 | QPt100Ω4 | -200.0 to 200.0 | 11 | E4 | -270.0 to 150.0 | 28 | L | -200.0 to 900.0 | 50 | QPt100Ω5 | -100.0 to 100.0 | 12 | J1 | -200.0 to 1200.0 | 31 | DC voltage (Linear) | 10mV | ±10mV | 51 | JPt50Ω | -200.0 to 649.0 | 13 | J2 | -200.0 to 900.0 | 32 | 20mV | ±20mV | 53 | Pt100Ω1 | -200.0 to 850.0 | 14 | J3 | -200.0 to 400.0 | 33 | 50mV | ±50mV | 54 | Pt100Ω2 | -200.0 to 400.0 | 15 | J4 | -100.0 to 200.0 | 34 | 100mV | ±100mV | 56 | Pt100Ω4 | -200.0 to 200.0 | 16 | T1 | -270.0 to 400.0 | 35 | 5V | ±5V | 57 | Pt100Ω5 | -100.0 to 100.0 | 17 | T2 | -200.0 to 200.0 | 37 | 10V | ±10V | | | | |
| No. | Measurement range | Scale range (°C) | No. | Measurement range | Scale range (°C) | No. | Measurement range | Scale range (°C) | | | | | | | | | | | | | | | | | | | | | | | | | | | | | | | | | | | | | | | | | | | | | | | | | | | | | | | | | | | | | | | | | | | | | | | | | | | | | | | | | | | | | | | | | | | | | | | | | | | | | | | | | | | | | | | | | | | | | | | | | | | | | | | | | | | | | | | | | | | | | | | | | | | | | | | | | | |
| 01 | Thermocouple | B | 0.0 to 1820.0 | 18 | Thermocouple | WRe5-26 | 0.0 to 2310.0 | 36 | Direct current (Linear) | 20mA | | 0 to 20mA | | | | | | | | | | | | | | | | | | | | | | | | | | | | | | | | | | | | | | | | | | | | | | | | | | | | | | | | | | | | | | | | | | | | | | | | | | | | | | | | | | | | | | | | | | | | | | | | | | | | | | | | | | | | | | | | | | | | | | | | | | | | | | | | | | | | | | | | | | | | | | | | | | | | | | |
| 02 | | R1 | 0.0 to 1760.0 | 19 | | W-WRe26 | 0.0 to 2310.0 | | | | | | | | | | | | | | | | | | | | | | | | | | | | | | | | | | | | | | | | | | | | | | | | | | | | | | | | | | | | | | | | | | | | | | | | | | | | | | | | | | | | | | | | | | | | | | | | | | | | | | | | | | | | | | | | | | | | | | | | | | | | | | | | | | | | | | | | | | | | | | | | | | | | | | | | | | | |
| 03 | | R2 | 0.0 to 1200.0 | 20 | | NiMo-Ni | -50.0 to 1410.0 | | | | | | | | | | | | | | | | | | | | | | | | | | | | | | | | | | | | | | | | | | | | | | | | | | | | | | | | | | | | | | | | | | | | | | | | | | | | | | | | | | | | | | | | | | | | | | | | | | | | | | | | | | | | | | | | | | | | | | | | | | | | | | | | | | | | | | | | | | | | | | | | | | | | | | | | | | | |
| 04 | | S | 0.0 to 1760.0 | 21 | | CR-AuFe | 0.0 to 280.0 K | 41 | Resistance thermometer | JPt100Ω1 | | -200.0 to 649.0 | | | | | | | | | | | | | | | | | | | | | | | | | | | | | | | | | | | | | | | | | | | | | | | | | | | | | | | | | | | | | | | | | | | | | | | | | | | | | | | | | | | | | | | | | | | | | | | | | | | | | | | | | | | | | | | | | | | | | | | | | | | | | | | | | | | | | | | | | | | | | | | | | | | | | | |
| 05 | | K1 | -200.0 to 1370.0 | 22 | | N | 0.0 to 1300.0 | | | 42 | | JPt100Ω2 | -200.0 to 400.0 | | | | | | | | | | | | | | | | | | | | | | | | | | | | | | | | | | | | | | | | | | | | | | | | | | | | | | | | | | | | | | | | | | | | | | | | | | | | | | | | | | | | | | | | | | | | | | | | | | | | | | | | | | | | | | | | | | | | | | | | | | | | | | | | | | | | | | | | | | | | | | | | | | | | | |
| 06 | | K2 | 0.0 to 600.0 | 23 | | PR5-20 | 0.0 to 1800.0 | | | 44 | | JPt100Ω4 | -200.0 to 200.0 | | | | | | | | | | | | | | | | | | | | | | | | | | | | | | | | | | | | | | | | | | | | | | | | | | | | | | | | | | | | | | | | | | | | | | | | | | | | | | | | | | | | | | | | | | | | | | | | | | | | | | | | | | | | | | | | | | | | | | | | | | | | | | | | | | | | | | | | | | | | | | | | | | | | | |
| 07 | | K3 | -200.0 to 300.0 | 24 | | PtRh40-20 | 0.0 to 1880.0 | | | 45 | | JPt100Ω5 | -100.0 to 100.0 | | | | | | | | | | | | | | | | | | | | | | | | | | | | | | | | | | | | | | | | | | | | | | | | | | | | | | | | | | | | | | | | | | | | | | | | | | | | | | | | | | | | | | | | | | | | | | | | | | | | | | | | | | | | | | | | | | | | | | | | | | | | | | | | | | | | | | | | | | | | | | | | | | | | | |
| 08 | | E1 | -270.0 to 1000.0 | 25 | | Plati II 1 | 0.0 to 1390.0 | | | 46 | | QPt100Ω1 | -200.0 to 649.0 | | | | | | | | | | | | | | | | | | | | | | | | | | | | | | | | | | | | | | | | | | | | | | | | | | | | | | | | | | | | | | | | | | | | | | | | | | | | | | | | | | | | | | | | | | | | | | | | | | | | | | | | | | | | | | | | | | | | | | | | | | | | | | | | | | | | | | | | | | | | | | | | | | | | | |
| 09 | | E2 | 0.0 to 700.0 | 26 | | Plati II 2 | 0.0 to 600.0 | | | 47 | | QPt100Ω2 | -200.0 to 400.0 | | | | | | | | | | | | | | | | | | | | | | | | | | | | | | | | | | | | | | | | | | | | | | | | | | | | | | | | | | | | | | | | | | | | | | | | | | | | | | | | | | | | | | | | | | | | | | | | | | | | | | | | | | | | | | | | | | | | | | | | | | | | | | | | | | | | | | | | | | | | | | | | | | | | | |
| 10 | | E3 | -270.0 to 300.0 | 27 | | U | -200.0 to 400.0 | | | 49 | | QPt100Ω4 | -200.0 to 200.0 | | | | | | | | | | | | | | | | | | | | | | | | | | | | | | | | | | | | | | | | | | | | | | | | | | | | | | | | | | | | | | | | | | | | | | | | | | | | | | | | | | | | | | | | | | | | | | | | | | | | | | | | | | | | | | | | | | | | | | | | | | | | | | | | | | | | | | | | | | | | | | | | | | | | | |
| 11 | | E4 | -270.0 to 150.0 | 28 | L | -200.0 to 900.0 | 50 | QPt100Ω5 | -100.0 to 100.0 | | | | | | | | | | | | | | | | | | | | | | | | | | | | | | | | | | | | | | | | | | | | | | | | | | | | | | | | | | | | | | | | | | | | | | | | | | | | | | | | | | | | | | | | | | | | | | | | | | | | | | | | | | | | | | | | | | | | | | | | | | | | | | | | | | | | | | | | | | | | | | | | | | | | | | | | | |
| 12 | | J1 | -200.0 to 1200.0 | 31 | DC voltage (Linear) | 10mV | ±10mV | 51 | JPt50Ω | -200.0 to 649.0 | | | | | | | | | | | | | | | | | | | | | | | | | | | | | | | | | | | | | | | | | | | | | | | | | | | | | | | | | | | | | | | | | | | | | | | | | | | | | | | | | | | | | | | | | | | | | | | | | | | | | | | | | | | | | | | | | | | | | | | | | | | | | | | | | | | | | | | | | | | | | | | | | | | | | | | | |
| 13 | | J2 | -200.0 to 900.0 | 32 | | 20mV | ±20mV | 53 | Pt100Ω1 | -200.0 to 850.0 | | | | | | | | | | | | | | | | | | | | | | | | | | | | | | | | | | | | | | | | | | | | | | | | | | | | | | | | | | | | | | | | | | | | | | | | | | | | | | | | | | | | | | | | | | | | | | | | | | | | | | | | | | | | | | | | | | | | | | | | | | | | | | | | | | | | | | | | | | | | | | | | | | | | | | | | |
| 14 | | J3 | -200.0 to 400.0 | 33 | | 50mV | ±50mV | 54 | Pt100Ω2 | -200.0 to 400.0 | | | | | | | | | | | | | | | | | | | | | | | | | | | | | | | | | | | | | | | | | | | | | | | | | | | | | | | | | | | | | | | | | | | | | | | | | | | | | | | | | | | | | | | | | | | | | | | | | | | | | | | | | | | | | | | | | | | | | | | | | | | | | | | | | | | | | | | | | | | | | | | | | | | | | | | | |
| 15 | | J4 | -100.0 to 200.0 | 34 | | 100mV | ±100mV | 56 | Pt100Ω4 | -200.0 to 200.0 | | | | | | | | | | | | | | | | | | | | | | | | | | | | | | | | | | | | | | | | | | | | | | | | | | | | | | | | | | | | | | | | | | | | | | | | | | | | | | | | | | | | | | | | | | | | | | | | | | | | | | | | | | | | | | | | | | | | | | | | | | | | | | | | | | | | | | | | | | | | | | | | | | | | | | | | |
| 16 | | T1 | -270.0 to 400.0 | 35 | | 5V | ±5V | 57 | Pt100Ω5 | -100.0 to 100.0 | | | | | | | | | | | | | | | | | | | | | | | | | | | | | | | | | | | | | | | | | | | | | | | | | | | | | | | | | | | | | | | | | | | | | | | | | | | | | | | | | | | | | | | | | | | | | | | | | | | | | | | | | | | | | | | | | | | | | | | | | | | | | | | | | | | | | | | | | | | | | | | | | | | | | | | | |
| 17 | | T2 | -200.0 to 200.0 | 37 | | 10V | ±10V | | | | | | | | | | | | | | | | | | | | | | | | | | | | | | | | | | | | | | | | | | | | | | | | | | | | | | | | | | | | | | | | | | | | | | | | | | | | | | | | | | | | | | | | | | | | | | | | | | | | | | | | | | | | | | | | | | | | | | | | | | | | | | | | | | | | | | | | | | | | | | | | | | | | | | | | | | | |

[4-wire resistance thermometer]

| No. | Measurement range | Scale range (°C) | No. | Measurement range | Scale range (°C) | No. | Measurement range | Scale range (°C) |
|-----|-------------------|------------------|-----|-------------------|------------------|-----|-------------------|------------------|
| 41 | JPt100Ω1 | -200.0 to 649.0 | 47 | QPt100Ω2 | -200.0 to 400.0 | 53 | Pt100Ω1 | -200.0 to 850.0 |
| 42 | JPt100Ω2 | -200.0 to 400.0 | 49 | QPt100Ω4 | -200.0 to 200.0 | 54 | Pt100Ω2 | -200.0 to 400.0 |
| 44 | JPt100Ω4 | -200.0 to 200.0 | 50 | QPt100Ω5 | -100.0 to 100.0 | 56 | Pt100Ω4 | -200.0 to 200.0 |
| 45 | JPt100Ω5 | -100.0 to 100.0 | 51 | JPt50Ω | -200.0 to 649.0 | 57 | Pt100Ω5 | -100.0 to 100.0 |
| 46 | QPt100Ω1 | -200.0 to 649.0 | 52 | Pt-Co | 4.0 to 374.0 K | | | |

3. RJ

```

R J  C A L C U L A T I O N
I N T      E X T
    
```

- ① This screen is displayed when select “thermocouple”.
- ② When 'INT' is selected RJ functionality is switched ON. Usually 'INT' is selected.
- ③ When 'EXT' is selected RJ functionality is switched OFF.

4. Unit

```

M E A S U R E   U N I T
° C      K
    
```

- ① Set the unit when measurement range is “thermocouple” or “resistance thermometer”.
- ② When measurement range is 'CR-AuFe' or 'Pt-Co' only then the unit is 'K' and '°C' is not selected.
- ③ When unit is changed, sometimes the setting range and decimal point position changes or initialization takes place automatically and relatively hence take care.

5. Measurement scope

```

R A N G E   S E T
- 0 2 0 0 . 0 ~ 1 3 7 0 . 0
    
```

[Linear scale]

```

R A N G E   S E T
0 0 0 . 0 0 ~ 0 1 0 . 0 0
    
```

- ① Set the measurement scope to be actually used for the scale range of measurement range.
- ② The meaning of thermocouple and resistance thermometer is as follows.
 - P in PID calculation is equivalent to 100%.
 - It becomes the maximum setting range like SV range etc.
- ③ In case of linear input, meaning of measurement scope is as follows.
 - It becomes the reference range which is the base of linear scale (with scale.)
- ④ Setting range is within the scale range of the measurement range that is selected.
- ⑤ When measurement scope is changed, sometimes setting range and decimal point position changes or initialization occurs automatically and relatively hence take care.

6. Linear scale

```



L I N E A R   S C A L E   D O T 1
0 0 0 0 . 0 ~ 2 0 0 0 . 0
    
```

- ① Measurement range is displayed only when 'Linear scale' is selected.
- ② Set scale (with scale) for reference range that is set in measurement scope. P of PID operation = Equivalent to 100%.
- ③ Set decimal point position in 'DOT', lower limit value (0%) on the lower left on the scale and higher limit value (100%) on the lower right of the scale.
- ④ When linear scale is changed, sometimes setting range and decimal point position changes or initialization occurs automatically and relatively hence take care.

| | |
|--|--|
| <p>7. Sensor correction 8 types</p> <div style="border: 1px solid black; padding: 5px; width: fit-content; margin: 10px auto;"> <p style="text-align: center;">INPUT SHIFT</p> <p style="text-align: center;">NO. 1 000.00</p> </div> | <ul style="list-style-type: none"> ① Set 8 types of sensor corrections (PV bias). ② After the settings, it is necessary to set the sensor correction that is to be used for each pattern/step in mode 2. ③ When measurement range, unit, measurement scope, linear scale etc is changed, sometimes the setting range and decimal point position changes automatically and relatively, hence take care. |
| <p>8. PV decimal point</p> <div style="border: 1px solid black; padding: 5px; width: fit-content; margin: 10px auto;"> <p style="text-align: center;">PV DISPLAY DOT</p> <p style="text-align: center;">1</p> </div> | <ul style="list-style-type: none"> ① Set the decimal point position of PV. ② Based on the decimal point position that is set, up to five digits including the integer part are displayed. Hence only if the number of digits of integer is less, more number of digits after the decimal point can be displayed within the range of decimal point position that is set. ③ When measurement range, unit, linear scale etc is changed, sometimes setting range and decimal point position changes automatically and relatively hence take care. |
| <p>9. Digital filter</p> <div style="border: 1px solid black; padding: 5px; width: fit-content; margin: 10px auto;"> <p style="text-align: center;">PV FILTER</p> <p style="text-align: center;">00.1 s</p> </div> | <ul style="list-style-type: none"> ① Do the first-order lag operation in PV. It is a valid function when PV is unstable. |
| <p>10. SV decimal point for displaying</p> <div style="border: 1px solid black; padding: 5px; width: fit-content; margin: 10px auto;"> <p style="text-align: center;">SV DISPLAY DOT</p> <p style="text-align: center;">1</p> </div> | <ul style="list-style-type: none"> ① Set the decimal point position of SV which is displayed at the upper display. ② Based on the decimal point position that is set, up to five digits including the integer part are displayed. Hence only if the number of digits of integer is less, more number of digits after the decimal point can be displayed within the range of decimal point position that is set. ③ When measurement range, unit, linear scale etc is changed, setting range and decimal point position may change automatically hence take care. |



7-8. Mode 6

Mode 6 performs the setting related to time event

| Settings screen | Description of the screen |
|--|---|
| <p>1. Mode screen</p> <div data-bbox="212 416 555 506" style="border: 1px solid black; padding: 5px; text-align: center;"> MODE 6 TIME EVENT </div> <p>[Lock status]</p> <div data-bbox="212 577 555 667" style="border: 1px solid black; padding: 5px; text-align: center;"> MODE 6 Lock TIME EVENT </div> <p>[Display OFF status]</p> <div data-bbox="212 739 555 828" style="border: 1px solid black; padding: 5px; text-align: center;"> MODE 6 NoDisp TIME EVENT </div> | <p>① Mode 6 screen.</p> <p>② By clicking the · key, 'Lock' and 'NoDisp' is displayed.</p> <p>③ For mode 6 settings screen, if setting change is to be prohibited select 'Lock'.</p> <p>④ When doing the settings by communications, set all the mode screens to 'Lock'.</p> <p>⑤ When settings screen of mode 6 is not displayed, select 'NoDisp'.</p> |
| <p>2. Time signal 8 types</p> <div data-bbox="212 1061 555 1151" style="border: 1px solid black; padding: 5px;"> TIME SIG ON000:00 No. 1 OFF001:00 </div> | <p>① Displays only the instrument with external signal output (DO).</p> <p>② Set 8 types of time signal.</p> <p>③ Set time from the time of starting the step to switching the time signal ON, in 'ON', and set the time from the time of switching the time signal ON to switching it OFF in 'OFF'.</p> <div data-bbox="691 1167 1417 1368" style="border: 1px solid black; padding: 10px; text-align: center;"> </div> <p>③ Set the unit in 'time unit' of mode 2.</p> <p>④ After the settings, it is necessary to set the time signal number that is to be used for each pattern/step in mode 2.</p> |
| <p>3. Real temperature compensation 8 types</p> <div data-bbox="212 1673 555 1762" style="border: 1px solid black; padding: 5px;"> GUARANTY SOAK No. 1 2000.0 </div> | <p>① Set 8 types of real temperature compensations.</p> <p>② After the settings, it is necessary to set real temperature compensation number that is to be used for each pattern/step in mode 2.</p> <p>③ When measurement range, unit, measurement scope, linear scale etc is changed, sometimes the setting range and decimal point position changes automatically and relatively, hence take care.</p> |
| <p>4. Waiting time alarm 8 types</p> <div data-bbox="212 2002 555 2092" style="border: 1px solid black; padding: 5px;"> WAIT TIMER No. 1 001:00 </div> | <p>① Set 8 types of waiting time alarms.</p> <p>② Unit is the unit set in 'time unit' of mode 2.</p> <p>③ After the settings, it is necessary to set the waiting time alarm number that is to be used for each pattern/step in mode 2.</p> |

7-9. Mode 7







Mode 7 performs the setting related to transmission signal output.

| Settings screen | Description of the screen |
|---|---|
| <p>1. Mode screen</p> <div data-bbox="212 416 555 506" style="border: 1px solid black; padding: 5px; text-align: center;"> MODE 7 TRANSMITTER </div> <p>[Lock status]</p> <div data-bbox="212 577 555 667" style="border: 1px solid black; padding: 5px; text-align: center;"> MODE 7 Lock TRANSMITTER </div> <p>[Display OFF status]</p> <div data-bbox="212 739 555 828" style="border: 1px solid black; padding: 5px; text-align: center;"> MODE 7 NoDisp TRANSMITTER </div> | <ul style="list-style-type: none"> ① Mode 7 screen. Only the specifications with transmission signal output are displayed. ② By clicking the · key, 'Lock' and 'NoDisp' is displayed. ③ For mode 7 settings screen, if setting change is to be prohibited select 'Lock'. ④ When doing the settings by communication, set all the mode screens to 'Lock'. ⑤ When settings screen of mode 7 is not displayed, select 'NoDisp'. |
| <p>2. Transmission types (High-performance type)</p> <div data-bbox="212 999 563 1088" style="border: 1px solid black; padding: 5px;"> TRANS(HIGH) KIND PV SV MV1 MV2 SUB </div> | <ul style="list-style-type: none"> ① Displays only the specifications with transmission signal output (High performance type). ② Sets transmission type of high-performance type. ③ When 'PV' is selected, measurement value (PV) is transmitted. ④ When 'SV' is selected, measurement value (SV) is transmitted. ⑤ When 'MV' is selected, output value (MV) is selected. ⑥ When 'MFB' is selected, operation terminal feedback value (MFB) is transmitted, but ON-OFF servo type only. ⑦ If 'SUB' is selected, setting value of subsidiary output is transmitted. Settings of subsidiary output become '8 types subsidiary output' of mode 7. ⑧ In case of output 2 specifications, output 1 side 'MV1' and output 2 side 'MV2' can be selected separately. ⑨ When transmission type is changed sometimes setting range and decimal point position changes or it may be initialized automatically and relatively hence take care. |
| <p>3. Transmission scale (High-performance type)</p> <div data-bbox="212 1657 563 1747" style="border: 1px solid black; padding: 5px;"> TRANS(HIGH) SCALE L-0200.0 ~H1370.0 </div> | <ul style="list-style-type: none"> ① Specifications with transmission signal output (High-performance type) only are displayed. ② Set a scale corresponding to transmission signal output (analog signal) of high performance type. ③ Set lower limit (0%) and higher limit (100%) of the scale for the minimum value (0%) and maximum value (100%) of the transmission signal output. ④ When transmission scale is changed, sometimes setting range and decimal point position changes automatically and relatively hence take care. |

| | |
|--|--|
| <p>4. Transmission type (General type)</p> <div style="border: 1px solid black; padding: 5px; width: fit-content; margin: 10px auto;"> <p>TRANS(NORMAL) KIND PV SV MV1 MV2 SUB</p> </div> | <ul style="list-style-type: none"> ① Specifications with transmission signal output (General type) only are displayed. ② Transmission type 'Normal' is selected. ③ When 'PV' is selected, measurement value (PV) is transmitted. ④ When 'SV' is selected, measurement value (SV) is transmitted. ⑤ When 'MV' is selected, output value (MV) is selected. ⑥ When 'MFB' is selected, operation terminal feedback value (MFB) is transmitted, but ON-OFF servo type only. ⑦ If 'SUB' is selected, setting value of subsidiary output is transmitted. Subsidiary output setting is '8 types subsidiary output' of mode 7. ⑧ In case of output 2 specifications, output 1 side 'MV1' and output 2 side 'MV2' can be selected separately. ⑨ When transmission type is changed sometimes setting range and decimal point position changes or it may be initialized automatically and relatively hence take care. |
| <p>5. Transmission scale (Normal type)</p> <div style="border: 1px solid black; padding: 5px; width: fit-content; margin: 10px auto;"> <p>TRANS(NORMAL) SCALE L-0200.0 ~H1370.0</p> </div> | <ul style="list-style-type: none"> ① Specifications with transmission signal output (Normal type) only are displayed. ② Set a scale corresponding to transmission signal output (analog signal) of normal type. ③ Set lower limit (0%) and higher limit (100%) of the scale for the minimum value (0%) and maximum value (100%) of the transmission signal output. ④ When transmission scale is changed, sometimes setting range and decimal point position changes automatically and relatively hence take care. |
| <p>6. Subsidiary output 8 types</p> <div style="border: 1px solid black; padding: 5px; width: fit-content; margin: 10px auto;"> <p>SUB OUT No. 1 000.0%</p> </div> | <ul style="list-style-type: none"> ① It is displayed when 'SUB' is selected in transmission type. ② Set 8 types of subsidiary outputs. ③ After the settings, it is necessary to set the subsidiary output number that is to be used for each pattern/step in mode 2. ④ When measurement range, unit, measurement scope, linear scale etc is changed, sometimes decimal point position changes automatically and relatively hence take care. |

7-10. Mode 8

Mode 8 performs the setting related to communications

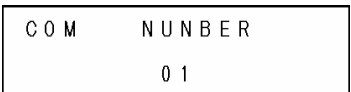
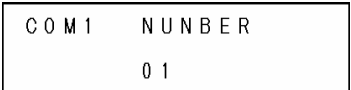
| Settings screen | Description of the screen |
|--|--|
| <p>1. Mode screen</p>  <p>[Lock status]</p>  <p>[Display OFF status]</p>  | <p>① Mode 8 screen. Only the instrument with communications is displayed.</p> <p>② By clicking the   key, 'Lock' and 'NoDisp' is displayed.</p> <p>③ For mode 8 settings screen, if setting change is to be prohibited select 'Lock'.</p> <p>④ When doing the settings by communications, set all the mode screens to 'Lock'.</p> <p>⑤ When settings screen of mode 8 is not displayed, select 'NoDisp'.</p> |
| <p>2. Communications speed</p>  <p>[Communications 2 port specifications]</p>  | <p>① Only the instrument with communications is displayed.</p> <p>② Set the communications speed.</p> <p>③ In case of communications 2 port specifications, this setting screen becomes the communications speed for COM1.</p> |
| <p>3. Instrument number</p>  <p>[Communications 2 port specifications]</p>  | <p>① Only the instrument with communications is displayed.</p> <p>② Set the instrument number.</p> <p>③ In case of communications 2 port specifications, this setting screen becomes the instrument number for COM1.</p> |







| | |
|--|---|
| <p>4. Communications function</p> <div style="border: 1px solid black; padding: 5px; margin: 10px 0;"> COM KIND COM TRANS </div> <p>[Communications 2 port specifications]</p> <div style="border: 1px solid black; padding: 5px; margin: 10px 0;"> COM1 KIND COM TRANS </div> | <ol style="list-style-type: none"> ① Only the instrument with communication is displayed. ② Set the communications function. ③ If 'COM' is selected it is higher order communications function. ④ If 'TRANS' is selected, it is communications transmission function. ⑤ In case of communications 2 port specifications, this setting screen becomes the communications function for COM1. |
| <p>5. Communications transmission types</p> <div style="border: 1px solid black; padding: 5px; margin: 10px 0;"> COM TRANS KIND PV SV MV1 MV2 SUB </div> <p>[Communications 2 port specifications]</p> <div style="border: 1px solid black; padding: 5px; margin: 10px 0;"> COM1 TRANS KIND PV SV MV1 MV2 SUB </div> | <ol style="list-style-type: none"> ① Only the instrument with communication and communication function is displayed when 'TRANS' is selected. ② Set the communications transmission type. ③ When 'PV' is selected, measurement value (PV) is transmitted. ④ When 'SV' is selected, measurement value (SV) is transmitted. ⑤ When 'MV' is selected, output value (MV) is selected. ⑥ When 'MFB' is selected, operation terminal feedback value (MFB) is transmitted, but ON-OFF servo type only. ⑦ If 'SUB' is selected, setting value of subsidiary output is transmitted. ⑧ In case of output 2 specifications, output 1 side 'MV1' and output 2 side 'MV2' can be selected separately. ⑨ In case of communications 2 port specifications, this setting screen becomes the communications transmission type for COM1. |
| <p>6. Communications protocol</p> <div style="border: 1px solid black; padding: 5px; margin: 10px 0;"> COM PROTOCOL MODBUS(RTU) </div> <p>[Communications 2 port specifications]</p> <div style="border: 1px solid black; padding: 5px; margin: 10px 0;"> COM1 PROTOCOL MODBUS(RTU) </div> | <ol style="list-style-type: none"> ① Only the instrument with communications is displayed. ② Set communications protocol. ③ If 'MODBUS (RTU)' is selected, MODBUS (RTU) is displayed. ④ If 'MODBUS (ASCII)' is selected, MODBUS (ASCII) is displayed. ⑤ If 'PRIVATE' is selected, usual CHINO protocol is displayed. ⑥ In case of communications 2 port specifications, this setting screen becomes the communications protocol for COM1. |
| <p>7. Communications character</p> <div style="border: 1px solid black; padding: 5px; margin: 10px 0;"> COM CHARACTER 8 BIT / NON / STOP1 </div> <p>[Communications 2 port specifications]</p> <div style="border: 1px solid black; padding: 5px; margin: 10px 0;"> COM1 CHARACTER 8 BIT / NON / STOP1 </div> | <ol style="list-style-type: none"> ① Only the instrument with communication and communication protocol is displayed when 'MODBUS' is selected. ② Set communication character (bit length, parity, stop bit). ③ In case of communications 2 port specifications, this setting screen becomes the communication character for COM1. |

| | |
|---|--|
| <p>8. Selecting communications 2 port function</p> <div style="border: 1px solid black; padding: 5px; width: fit-content; margin: 10px auto;"> COM2 PORT SELECT COM ENG </div> | <ol style="list-style-type: none"> ① Only the instrument with communications 2 port specifications is displayed. ② Set the function of communications 2 port. ③ If 'COM' is selected 2 port communications is possible from the rear terminal. ④ If 'ENG' is selected 1 port communications is possible from the rear terminal and engineering port communication that exists in the front is possible. |
| <p>9. Communications speed for COM2</p> <div style="border: 1px solid black; padding: 5px; width: fit-content; margin: 10px auto;"> COM2 BIT RATE 9600 bps </div> | <ol style="list-style-type: none"> ① In communications 2 port specifications, communications 2 port function selection is displayed only at the time of selecting 'COM'. ② Set the communications speed for COM2. |
| <p>10. Instrument number for COM2</p> <div style="border: 1px solid black; padding: 5px; width: fit-content; margin: 10px auto;"> COM2 NUMBER 01 </div> | <ol style="list-style-type: none"> ① In communications 2 port specifications, communications 2 port function selection is displayed only at the time of selecting 'COM'. ② Set the instrument number for COM2. |
| <p>11. Communications function for COM2</p> <div style="border: 1px solid black; padding: 5px; width: fit-content; margin: 10px auto;"> COM2 KIND COM TRANS </div> | <ol style="list-style-type: none"> ① In communications 2 port specifications, communications 2 port function selection is displayed only at the time of selecting 'COM'. ② Set the communications function for COM2. ③ If 'COM' is selected it becomes high order communications function. ④ If 'TRANS' is selected it becomes communications transmission function. |
| <p>12. Communications transmission types for COM2</p> <div style="border: 1px solid black; padding: 5px; width: fit-content; margin: 10px auto;"> COM2 TRANS KIND PV SV MV1 MV2 SUB </div> | <ol style="list-style-type: none"> ① In communication 2 port specifications, communications function for COM2 is displayed only when 'TRANS' is selected. ② Set communications transmission type for COM2. ③ When 'PV' is selected, measurement value (PV) is transmitted. ④ When 'SV' is selected, measurement value (SV) is transmitted. ⑤ When 'MV' is selected, output value (MV) is selected. ⑥ When 'MFB' is selected, operation terminal feedback value (MFB) is transmitted. But the output format can be selected only in case of ON OFF servo type. ⑦ If 'SUB' is selected, setting value of subsidiary output is transmitted. ⑧ In case of output 2 specifications, output 1 side 'MV1' and output 2 side 'MV2' can be selected separately. |

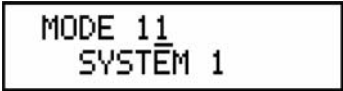
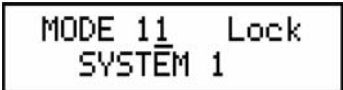
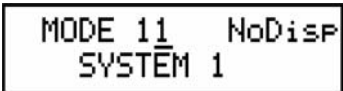
| | |
|--|--|
| <p>13. Communications protocol for COM2</p> <div style="border: 1px solid black; padding: 5px; width: fit-content; margin: 10px auto;"> <p>COM2 PROTOCOL MODBUS (RTU)</p> </div> | <ul style="list-style-type: none"> ① In communications 2 port specifications, communications 2 port function selection is displayed only at the time of selecting 'COM'. ② Set the communications protocol for COM2. ③ If 'MODBUS (RTU)' is selected, MODBUS (RTU) is displayed. ④ If 'MODBUS (ASCII)' is selected, MODBUS (ASCII) is displayed. ⑤ If 'PRIVATE' is selected, usual CHINO protocol is displayed. |
| <p>14. Communications character for COM2</p> <div style="border: 1px solid black; padding: 5px; width: fit-content; margin: 10px auto;"> <p>COM2 CHARACTER 8 BIT / NON / STOP 1</p> </div> | <ul style="list-style-type: none"> ① In communications 2 port specifications, communications protocol for COM2 is displayed only when 'MODBUS' is selected. ② Set communications character (bit length/parity/stop bit) for COM2. |

7-11.Mode 11

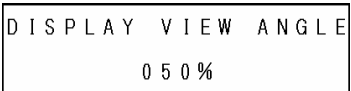
Mode 11 performs the setting related to system (Initial settings of the system).

| Settings screen | Description of the screen |
|---|--|
| <p>1.Mode screen</p>  <p>[Lock Status]</p>  <p>[Display OFF status]</p>  | <p>① Mode 11 screen.</p> <p>② By clicking the · key, 'Lock' and 'NoDisp' is displayed.</p> <p>③ For mode 11 settings screen, if setting change is to be prohibited select 'Lock'.</p> <p>④ When doing the settings by communications, set all the mode screens to 'Lock'.</p> <p>⑤ When settings screen of mode 11 is not displayed, select 'NoDisp'.</p> |
| <p>2. Display back light</p>  | <p>① Set the back light color of lower display.</p> <p>② If 'GREEN' is selected, usually green color is displayed.</p> <p>③ If 'ORANGE' is selected, usually orange color is displayed.</p> <p>④ If 'AUTO' is selected, usually green color is displayed however under the following conditions, orange color is displayed.</p> <ul style="list-style-type: none"> · When any of the alarms is activated. · When an error message is displayed. <p>By effective use of this function, alarm on/off can be judged at a glance.</p> |
| <p>3. Display contrast</p>  | <p>① It adjusts the contrast of LCD (Liquid crystal display) of lower display window.</p> <p>② Adjust and set the LCD such that the characters are clearly visible. 40 to 70% of range is suitable for setting value. When set the range over or under, stripes appear in the LCD. Do not change the setting (initial value 50%) in ordinary use.</p> <p>③ Contrast especially affects the surrounding temperature hence do this adjustment approximately one hour after switching on the power supply and after the surrounding temperature becomes stable.</p> |
| <p>4. Key back light</p>  | <p>① It sets the illumination/non-illumination function of key backlight.</p> <p>② If 'AUTO' is selected, the following operation takes place.</p> <ul style="list-style-type: none"> · Usually it is non-illuminated, however when power is supplied or if any of the key is pressed, it illuminates and gets switched off if no key operation is done for approximately 30 seconds. <p>③ If 'OFF' is selected, it usually gets switched OFF.</p> <p>④ If 'ON' is selected, it usually illuminates.</p> |



5. External signal layout

| | |
|----------|----------|
| TERMINAL | No. 1 2 |
| DI | RUN/STOP |

- ① Only the specifications with external signal input or specifications with external signal output are displayed.
- ② In external signal input (DI) and external signal output, a function for terminal number is allotted.
- ③ In 'TERMINAL No.' terminal number having external signal input (DI) or external signal output (DO) function is displayed hence set the terminal number (No.) and the function corresponding to it.
- ④ External signal input (DI) function is as follows.
 - 'RUN/STOP' : Program drive. Runs when OFF, stops when OFF.
 - 'ADV' : Program drive. Advances from ON (momentary signal) to OFF.
 - 'RESET' : Program drive. Resets when ON (momentary signal).
 - 'WAIT' : Program drive. Waits when ON.
 - 'FAST' : Program drive. Speeds up when ON.
 - 'PTN 1' : Select pattern. BCD code is '1' when ON.
 - 'PTN 2' : Select pattern. BCD code is '2' when ON.
 - 'PTN 4' : Select pattern. BCD code is '4' when ON.
 - 'PTN 8' : Select pattern. BCD code is '8' when ON.
 - 'PTN10' : Select pattern. BCD code is '10' when ON.
 - 'PTN20' : Select pattern. BCD code is '20' when ON.
 - 'MAN1/AUTO1' : Manual output operation on (MANUAL) output 1 side, when ON. Automatic output operation (AUTO) on output 1 side, when OFF.
 - 'MAN2/AUTO2' : Manual output operation (MANUAL) on output 2 side, when ON. Automatic output operation (AUTO) on output 2 side, when OFF.

※ However only output 2 specifications can be selected.



 - 'PRESET/AUTO' : Preset manual (PRESET) when ON.
Automatic output operation (AUTO) when OFF.
 - 'ALARM RESET' : Cancel alarm (ALARM RESET) output when ON (momentary signal).
 - 'PV HOLD' : PV HOLD when ON.
 - 'TIMER 1' : Timer 1 starts when ON. Timer 1 is reset when OFF.
 - 'TIMER 2' : Timer 2 starts when ON. Timer 2 is reset when OFF.
 - 'TIMER 3' : Timer 3 starts when ON. Timer 3 is reset when OFF.
 - 'TIMER 4' : Timer 4 starts when ON. Timer 4 is reset when OFF.
- ⑤ External signal output (DO) function is as follows.
 - From 'TS1' : Time signal. From time signal 1.
 - To 'TS8' : Time signal. To time signal 8.
 - 'RUN/STOP' : Status. Runs when ON and stops when OFF.
 - 'ADV' : Status. Advances when ON (Momentary signal).
 - 'RESET' : Status. Resets when ON.
 - 'WAIT' : Status. Waits when ON.
 - 'END' : Status. Ends when ON.
- ⑥ No setting condition '— — — —' is displayed when shipped from factory. If set any function once, no setting condition is not displayed.
- ⑦ Allotted setting is not initialized even if setting content is initialized.

| | |
|---|--|
| <p>6. Alarm output check</p> <div style="border: 1px solid black; padding: 5px; width: fit-content; margin: 10px auto;"> ALARM OUT CHECK OFF AL1 2 3 4 </div> | <ol style="list-style-type: none"> ① It is a check function of alarm output. ② When this setting screen is displayed, the current alarm activation status of alarm of 4 points is OFF. When select the alarm which would like to ON and click  key, it become ON until selecting OFF. Using this function effectively facilitates the system checking of the final product. ③ When this screen is removed, alarm output automatically returns to current alarm activation status. |
| <p>7. Time signal output testing</p> <div style="border: 1px solid black; padding: 5px; width: fit-content; margin: 10px auto;"> TIME SIGNAL CHECK TS No. 0 (0=NON) </div> | <ol style="list-style-type: none"> ① Displays only the instrument with external signal output (DO). ② It is a testing function of time signal output. ③ When this setting screen is displayed, current activation status of maximum 8 point time signal output become OFF automatically. When select the time signal which make put in output status and click the  key, become output status until selecting No.0 (NON). Using this function effectively facilitates system checking of final product. ④ When this screen is removed, time signal output automatically returns to present activation status. ⑤ If do not allocate external signal, corresponded TS1 to 8 of upper display are lighted in this function. |
| <p>8. Checking status output</p> <div style="border: 1px solid black; padding: 5px; width: fit-content; margin: 10px auto;"> STATUS OUT CHECK OFF </div> | <ol style="list-style-type: none"> ① Displays only the instrument with external signal output (DO). ② Check function of status output. ③ When this setting screen is displayed, current activation status of maximum 5 point status become OFF automatically. When select the status which make put in output status and click the  key, become output status until selecting OFF. ④ When this screen is removed, status output automatically returns to current activation status. ⑤ This function is effective only in the status output operation, and program operation status and operation of display contents are not changed. |

| | |
|---|--|
|  Precaution | <p>All outputs are turned OFF. When it is troubled by becoming OFF, click the mode key, and remove from the alarm checking status output screen.</p> |
|---|--|

7-12. Mode 12

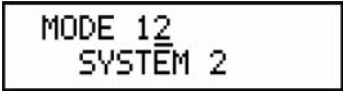
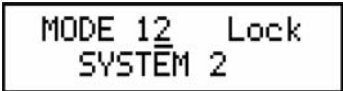
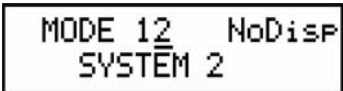
Mode 12 performs the setting related to system (Customer scale correction).

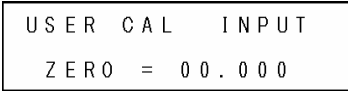
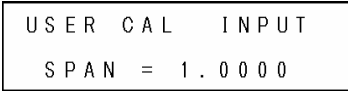
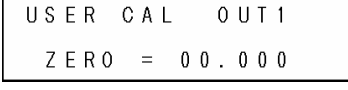
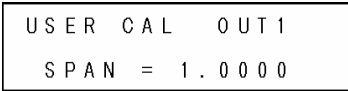
| Settings screen | Description of the screen |
|--|---|
| <p>1. Mode screen</p>  <p>[Lock Status]</p>  <p>[Display OFF status]</p>  | <p>① Mode 12 screen.</p> <p>② By clicking the · key, 'Lock' and 'NoDisp' is displayed.</p> <p>③ For mode 12 settings screen, if setting change is to be prohibited select 'Lock'.</p> <p>④ When doing the settings by communications, set all the mode screens to 'Lock'.</p> <p>⑤ When settings screen of mode 12 is not displayed, select 'NoDisp'.</p> |
| <p>2. Measurement range, zero correction</p>  | <p>① It is a function that performs zero correction (Bias operation) of measurement range.</p> <p>② '0.0' being the standard, if minus value is set, it indicates low measurement value. If plus value is set, it indicates high measurement value.</p> |
| <p>3. Measurement range span correction</p>  | <p>① It is a function that does the span correction (coefficient calculation) of measurement range.</p> <p>② '1.0' being the standard, if a small value is set tilting becomes smaller indicating lower measurement value. On the other hand if a large value is set, the tilting is bigger indicating higher measurement value.</p> |
| <p>4. Output 1 zero correction</p>  | <p>① Output format of output 1 displays current output format or voltage output format only.</p> <p>② It is a function that does the zero correction (bias operation) of output 1.</p> <p>③ '0.0' being the standard, if minus value is set, it indicates low output value. If plus value is set, it indicates high output value.</p> |
| <p>5. Output 1 span correction</p>  | <p>① Output format of output 1 displays current output type or voltage output type only.</p> <p>② It is a function that does the span correction (coefficient calculation) of output 1.</p> <p>③ '1.0' being the standard, if a small value is set tilting becomes smaller indicating lower output value. On the other hand if a large value is set, the tilting is bigger indicating higher output value.</p> |

| | |
|---|--|
| <p>6. Output 2 zero correction</p> <div style="border: 1px solid black; padding: 5px; width: fit-content; margin: 10px auto;"> <pre>USER CAL OUT2 ZERO = 00.000</pre> </div> | <ol style="list-style-type: none"> ① Output format of output 2 displays current output type or voltage output type only. ② It is a function that does the zero correction (bias operation) of output 2. ③ '0.0' being the standard, if minus value is set, it indicates low output value. If plus value is set, it indicates high output value. |
| <p>7. Output 2 span correction</p> <div style="border: 1px solid black; padding: 5px; width: fit-content; margin: 10px auto;"> <pre>USER CAL OUT2 SPAN = 1.0000</pre> </div> | <ol style="list-style-type: none"> ① Output format of output 2 displays current output type or voltage output type only. ② It is a function that does the span correction (coefficient calculation) of output 2 side. ③ '1.0' being the standard, if a small value is set tilting becomes smaller indicating lower output value. On the other hand if a large value is set, the tilting is bigger indicating higher output value. |
| <p>8. Transmission output zero correction (High-performance type)</p> <div style="border: 1px solid black; padding: 5px; width: fit-content; margin: 10px auto;"> <pre>USER CAL TRANS(H) ZERO = 00.000</pre> </div> | <ol style="list-style-type: none"> ① Only the instrument with transmission signal output (High performance type) is displayed. ② It is function that does the zero correction (bias operation) of transmission output (High performance type). ③ '0.0' being the standard, if minus value is set, it indicates low output value. If plus value is set, it indicates high output value. |
| <p>9. Transmission output span correction (High-performance type)</p> <div style="border: 1px solid black; padding: 5px; width: fit-content; margin: 10px auto;"> <pre>USER CAL TRANS(H) SPAN = 1.0000</pre> </div> | <ol style="list-style-type: none"> ① Only the instrument with transmission signal output (High performance type) is displayed. ② It is function that does the span correction (coefficient calculation) of transmission output (High performance type). ③ '1.0' being the standard, if a small value is set tilting becomes smaller indicating lower output value. On the other hand if a large value is set, the tilting is bigger indicating higher output value. |
| <p>10. Transmission output zero correction (Normal type)</p> <div style="border: 1px solid black; padding: 5px; width: fit-content; margin: 10px auto;"> <pre>USER CAL TRANS(N) ZERO = 00.000</pre> </div> | <ol style="list-style-type: none"> ① Only the instrument with transmission signal output (Normal type) is displayed. ② It is a function that does the zero correction (bias operation) of transmission output (Normal type). ③ '0.0' being the standard, if minus value is set, it indicates low output value. If plus value is set, it indicates high output value. |
| <p>11. Transmission output span correction (Normal type)</p> <div style="border: 1px solid black; padding: 5px; width: fit-content; margin: 10px auto;"> <pre>USER CAL TRANS(N) SPAN = 1.0000</pre> </div> | <ol style="list-style-type: none"> ① Only instrument with transmission signal output (Normal type) is displayed. ② It is a function that does the span correction (coefficient calculation) of transmission output (Normal type). ③ '1.0' being the standard, if a small value is set tilting becomes smaller indicating lower output value. On the other hand if a large value is set, the tilting is bigger indicating higher output value. |

| | |
|---|--|
| <p>12. CT input zero correction</p> <div style="border: 1px solid black; padding: 5px; width: fit-content; margin: 10px auto;"> USER CAL CT ZERO = 00.000 </div> | <p>① Only the instrument with heater snapping wire alarm is displayed. ② It is a function that does the zero correction (Bias operation) of CT input. ③ '0.0' being the standard, if minus value is set, it indicates low measurement value. If plus value is set, it indicates high measurement value.</p> |
| <p>13. CT input span correction</p> <div style="border: 1px solid black; padding: 5px; width: fit-content; margin: 10px auto;"> USER CAL CT SPAN = 1.0000 </div> | <p>① Only the instrument with heater snapping wire alarm is displayed. ② It is a function that does the span correction (Coefficient calculation) of CT input. ③ '1.0' being the standard, if a small value is set tilting becomes smaller indicating lower indicating value. On the other hand if a large value is set, the tilting is bigger indicating higher indicating value.</p> |

7-13. Initializing the setup parameter

If set contents are to be returned to initial value, you can do it by the following procedure. There are two types of initializations and you can select from them. Once initialization is executed, you will not be able to return to the original setting contents hence take care.

| Initialization type | Procedure | Screen that is being initialized |
|--|--|--|
| <p>1. Initializing the basic setting contents (Mode 0 to Mode 11)</p> <p>※ However program pattern is not initialized.</p> | <p>① Cut off the power supply. ② Switch on the power supply while pressing the RUN/ MODE key. ③ After confirming that the screen shown on the right is displayed, release the MODE key. ④ After the initialization is done, operation screen is displayed.</p> | <div style="border: 1px solid black; padding: 10px; text-align: center;"> Parameter Initialize </div> |
| <p>2. Initializing all the setting contents (Mode 0 to Mode 11)</p> <p>※ Program pattern is also initialized.</p> | <p>① Cut off the power supply. ② Switch on the power supply while pressing the RUN/ MODE key and ▲/M/ ENT key. ③ After confirming that the screen shown on the right is displayed, release the RUN/ MODE key and ▲/M/ ENT key. ④ After the initialization is done, operation screen is displayed.</p> | <div style="border: 1px solid black; padding: 10px; text-align: center;"> All Parameter Initialize </div> |

* 'External signal allocation' is not initialized.

7-14. Precautions while setting

| Precautions | Explanation |
|--|---|
| 1. Precautions regarding the setting range. | <ul style="list-style-type: none"> · In numeric value settings parameter, there exists a range of numeric value that can be set, hence take care. · For example, 'SV range' of mode 2, is in the numeric value range set in scaling or 'measurement range' of mode 5. · If you try to set a numeric value exceeding the numeric value range that can be set, an error message is displayed. When an error message is displayed confirm the contents of the error message and do the proper settings. |
| 2. When a setting is changed, sometimes the set contents of other settings change. | <ul style="list-style-type: none"> · If the setting of important key parameters is changed, the decimal point position or the setting range of the set value of other related settings screen may sometimes change or may be initialized. · For example if 'measurement range', 'measurement scope', 'linear scale' of mode 5, 'alarm status' of mode 3, transmission type' of mode 7 etc. changed, the set contents of the other settings screen related to them will change. · If the settings of these key parameters is changed, reconfirm the set contents of other settings screen. |
| 3. When 'time 000:00' is to be set in program pattern. | <ul style="list-style-type: none"> · When setting the program pattern in mode 2, for considering the SV of next step momentarily (by step), 'time 000:00' can be set. 'Time 000:00' can also be set in continuous steps however when a program pattern that has set 'time 000:00' for many continuous steps, as error may sometimes occur in the entire system without correct control operation being performed, hence do not do such settings. · In step 'time 000:00', only the operation of changing momentarily only the SV that is set is done. As a result, various calculation processes (PID, alarm, sensor correction etc.) for each step cannot be performed. However those setting contents are valid in 'time 000:00' step also. For example, set 'time 000:00' in step number 3 and set alarm number 4 in that step, in step number 4 which is the next step if alarm number 0 is set, the alarm of step number 04 starts operating by using alarm number 4. · In step 'time 000:00', real temperature compensation and time signal do not operate. If you want to operate those functions at least for a short time, set 'time 000:01' or more. |

7-15. Error message

7-15-1. Usual error display

If proper settings and operation is not done, following error messages are displayed for around 3 seconds. Confirm the contents of the error message and do the proper settings and operation again.

| Error message | Error contents |
|---|--|
| 1. <div style="border: 1px solid black; padding: 5px; width: fit-content; margin: 10px auto;"> ERROR No. 2 2 SV RANGE OVER </div> | <ul style="list-style-type: none"> • SV is exceeding the measurement range. • Confirm the measurement range and do the settings again. |
| 2. <div style="border: 1px solid black; padding: 5px; width: fit-content; margin: 10px auto;"> ERROR No. 5 6 PATTERN IS RUNNING </div> | <ul style="list-style-type: none"> • Pattern cannot be eliminated during operation (RUN). • Eliminate the pattern when it is not operating. |
| 3. <div style="border: 1px solid black; padding: 5px; width: fit-content; margin: 10px auto;"> ERROR No. 5 1 PATTERN EXIST </div> | <ul style="list-style-type: none"> • Pattern of the copying destination is not cleared. • Confirm the copying destination and do the settings again. |
| 4. <div style="border: 1px solid black; padding: 5px; width: fit-content; margin: 10px auto;"> ERROR No. 6 0 PATTERN NO SETTING </div> | <ul style="list-style-type: none"> • Pattern of copy source is not set. • Set the pattern of copy source. • Pattern is not set. • Set the pattern. |
| 5. <div style="border: 1px solid black; padding: 5px; width: fit-content; margin: 10px auto;"> ERROR No. 6 5 AT1 : ONLY RUN </div> | <ul style="list-style-type: none"> • AT1 is not starting as screen is not operating (RUN). • Start AT1 after operating (RUN) the screen. |
| 6. <div style="border: 1px solid black; padding: 5px; width: fit-content; margin: 10px auto;"> ERROR No. 6 6 AT2 : ONLY RESET PRG </div> | <ul style="list-style-type: none"> • AT2 is not starting as status is not RESET status. • Start AT2 after changing the status to RESET. |
| 7. <div style="border: 1px solid black; padding: 5px; width: fit-content; margin: 10px auto;"> ERROR No. 6 7 AT3 : ONLY RESET PRG </div> | <ul style="list-style-type: none"> • AT3 is not starting as status is not RESET status. • Start AT3 after changing the status to RESET. |
| 8. <div style="border: 1px solid black; padding: 5px; width: fit-content; margin: 10px auto;"> ERROR No. 7 6 AT4 : ONLY RUN </div> | <ul style="list-style-type: none"> • AT4 is not starting as status is not operating (RUN). • Start AT4 after changing to operate (RUN). |

| | |
|--|--|
| <p>9.</p> <div style="border: 1px solid black; padding: 5px; width: fit-content;"> ERROR No. 2 3 SV SCOPE OVER </div> | <ul style="list-style-type: none"> ▪ SV section of PID number 9 is out of scope. ▪ Confirm the SV section and do the settings again. |
| <p>10.</p> <div style="border: 1px solid black; padding: 5px; width: fit-content;"> ERROR No. 2 1 INVERTED L > H </div> | <ul style="list-style-type: none"> ▪ L is exceeding H. ▪ Confirm L/H and do the settings again. |
| <p>11.</p> <div style="border: 1px solid black; padding: 5px; width: fit-content;"> ERROR No. 2 4 INVERTED Z > S </div> | <ul style="list-style-type: none"> ▪ Z is exceeding S. ▪ Confirm Z/S and do the settings again. |
| <p>12.</p> <div style="border: 1px solid black; padding: 5px; width: fit-content;"> ERROR No. 2 5 LINEAR RANGE OVER </div> | <ul style="list-style-type: none"> ▪ Linear range is exceeding the scope of measurement range. ▪ Confirm the measurement range and do the settings again. |
| <p>13.</p> <div style="border: 1px solid black; padding: 5px; width: fit-content;"> ERROR No. 6 8 F. B. AT : ONLY RESET </div> | <ul style="list-style-type: none"> ▪ F.B. tuning is not starting as the status is not RESET status. ▪ Start F.B. tuning after making the status as RESET. |
| <p>14.</p> <div style="border: 1px solid black; padding: 5px; width: fit-content;"> ERROR No. 3 7 PTN / DRV SELECT EXT </div> | <ul style="list-style-type: none"> ▪ As pattern selection system or program drive system has selected exterior, operation cannot be done by front key. ▪ When doing the operation by front key, change the pattern selection system. |
| <p>15.</p> <div style="border: 1px solid black; padding: 5px; width: fit-content;"> ERROR No. 6 1 STEP REPEAT MISS </div> | <ul style="list-style-type: none"> ▪ Operation cannot be started as there is an error in step repetition setting. ▪ Start the operation after reconfirming the settings. |
| <p>16.</p> <div style="border: 1px solid black; padding: 5px; width: fit-content;"> ERROR No. 7 0 PID : ONLY RESET </div> | <ul style="list-style-type: none"> ▪ Control algorithm is not changed because of program operating. ▪ Change the control algorithm after stopping the program operating. |
| <p>17.</p> <div style="border: 1px solid black; padding: 5px; width: fit-content;"> ERROR No. 7 1 TIME : ONLY RESET </div> | <ul style="list-style-type: none"> ▪ Time is not changing as status is not RESET status. ▪ Change the time after changing the status to RESET. |

7-15-2. System error display

If an abnormality occurs in the system, the following error messages are displayed for around 2 seconds. Confirm the contents of the error message and contact the dealer or our nearest office.

| Error message | Error contents |
|--|--|
| 1. <div style="border: 1px solid black; padding: 5px; width: fit-content; margin: 5px auto;"> SYSTEM ERROR No. 01 CALIBRATION ERROR </div> | <ul style="list-style-type: none"> • Calibration data abnormality |
| 2. <div style="border: 1px solid black; padding: 5px; width: fit-content; margin: 5px auto;"> SYSTEM ERROR No. 06 RAM BACK UP ERROR </div> | <ul style="list-style-type: none"> • Battery backup abnormality |
| 3. <div style="border: 1px solid black; padding: 5px; width: fit-content; margin: 5px auto;"> SYSTEM ERROR No. 10 A / D COUNT : PV </div> | <ul style="list-style-type: none"> • Abnormality in A/D conversion for PV |
| 4. <div style="border: 1px solid black; padding: 5px; width: fit-content; margin: 5px auto;"> SYSTEM ERROR No. 11 A / D COUNT : RJ </div> | <ul style="list-style-type: none"> • Abnormality in A/D conversion for RJ |

7-15-3. Warning display

If proper settings and operation is not done, following error messages are displayed for around 2 seconds. Confirm the contents of the warning message and do the proper settings and operation again.

| Warning message | Warning contents |
|--|--|
| 1. <div style="border: 1px solid black; padding: 5px; width: fit-content; margin: 5px auto;"> WARNING No. 10 KEY LOCK </div> | <ul style="list-style-type: none"> • Setting is not changed because of the [Lock] condition at the mode screen. • Change the setting after canceling the [Lock] condition. |

8. Initial settings

In '7. Setting screen' setting screen for each mode is explained, but you need not set all of them. The customer should select and set the required parameters depending on the specifications of the controller, system configuration of final product, control conditions etc.

Procedure for setting the minimum limit which is always to be done in the beginning for the finished product is explained here. Do the other settings as per the requirement.

: Always set : Set as per the requirement

| | |
|--|---|
| ① Set 'measurement range' : Mode 5 | ※ Set the measurement range that suits the sensor and the scale range. |
| ② Set 'measurement scope' : Mode 5 | ※ Set the range that is to be actually used. For linear input, set standard range. In case of thermocouple and resistance initial value is also okay. |
| ③ Setting 'linear scale' : Mode 5 | ※ Set the scale incase of linear input. |
| ④ Setting 'Direct/reverse' of control operation : Mode 4 | ※ Set the control operation. |
| ⑤ Setting 'Program pattern' : Mode 2 | ※ Set program pattern. |
| ⑥ Setting 'PID' : Mode 3 | ※ Set the PID. |
| ⑦ 'PID number and Alarm number' : Mode 2 | ※ Set PID number in each step of program pattern that is set. |
| ⑧ Select 'Pattern No.' : Operation screen | ※ Select the pattern number to be executed. |
| ⑩ 'RUN' operation : Operation screen | ※ Perform RUN and start the operation. |

9. Operation

9-1. Confirmations before operation



Confirm the following contents before starting the operation.



















| Item | Confirmation contents |
|-----------------|--|
| 1. Wiring | <ul style="list-style-type: none"> Confirm that the wiring is correct. Especially confirm very properly the wiring of high voltage parts like power supply, output and alarm. Confirm that the terminal screw is not loose. Confirm the wiring of not only the controller but also of the entire finished product. Especially proper confirmation of periphery of operation terminal (thyristor regulator, heater, motor etc.) is important. |
| 2. Power supply | <ul style="list-style-type: none"> Confirm that the power supply is in the rating range. |
| 3. Set contents | <ul style="list-style-type: none"> Confirm that the set contents are correct. When power supply is inserted confirm that the status is RESET status. In RUN status control operation is started immediately. As per the requirement if output is not to be displayed, set 0% in manual output operation. |





| | |
|--|---|
|  Precautions | <p>① If power supply other than the rated power supply is connected, this controller may become out of order, or its performance may deteriorate or it may malfunction etc.</p> <p>② If excessive current or excessive voltage is applied to input output terminal of this controller, this controller may become out of order, or its performance may deteriorate or it may malfunction etc.</p> |
|--|---|

9-2. Program operation and run operation

9-2-1. Run operation

| Status | Key operation and operation screen | Description |
|----------|---|---|
| 1. RESET | <p>[Key operation] In operation screen, click the  key and then click  key.</p> <p>[Operation screen] </p> | <ul style="list-style-type: none"> Resets (release) the program operation. It is enabled in RUN status or STOP status. RESET status is the status in which program operation is not executing, output value is 0% and alarm operation does not run. When the step number is progressing due to program operation etc., the step number returns to '00' due to RESET operation. In case of constant value operation in RESET status, as it is a normal control operation, alarm operation is also executed. |

| | | |
|----------------|---|--|
| <p>2. RUN</p> | <p>In [Key operation] operation screen, click  key after clicking  key.</p> <p>[Operation screen]</p>  | <ul style="list-style-type: none"> • It is RUN of program operation. • It is enabled in RESET status or STOP status. • Execute control operation according to the program pattern. • If RUN is executed in RESET status, program operation starts. If RUN is executed in STOP status, program operation reopens. |
| <p>3. STOP</p> | <p>In [key operation] operation screen, click  key after clicking  key.</p> <p>[Operation screen]</p>  | <ul style="list-style-type: none"> • STOP of program operation. • It is enabled in RUN status. • If STOP is executed in RUN status, program pattern (SV and time) is stopped and at that time control operation is continued using SV (It becomes a constant value operation). |
| <p>4. ADV</p> | <p>In [key operation] operation screen click  key after clicking  key.</p> <p>[Operation screen]</p>  | <ul style="list-style-type: none"> • It is advancing (progress) of step. • It is enabled in RUN status or STOP status. • If ADV operation is done in RUN status, the program operation continues from the beginning of advance step. If ADV operation is done in STOP status, the program operation has STOP status at the beginning of advance step. • In one time ADV operation, progress is by one step hence perform those many number of ADV operations for the number of progress steps. |
| <p>5. PTN</p> | <p>In [key operation] operation screen click  key after clicking  key. After that select a number using,  key  key.</p> <p>[Operation screen]</p>  | <ul style="list-style-type: none"> • Select Pattern number. • It is enabled in RESET status. • Pattern number selection status is obtained in RESET status by clicking  key after  key. After that, by using the  key or  key, select the pattern number for which operation is to be done. At that time the number selected in No. of PTN is displayed in upper display window. |

| | | |
|----------------|---|---|
| <p>6. FAST</p> | <p>In [key operation] operation screen, hold down  key after clicking  key.</p> <p>[Operation screen]</p>  | <ul style="list-style-type: none"> ▪ It is the FAST (fast forward) status of program pattern. ▪ It is enabled in RUN status. ▪ If RUN operation is done again in RUN status, the program pattern progresses from a speed of 'number of times' to a speed of 'ten times that number' only when  key is clicked. When  key is released, FAST status is cancelled. ▪ In case of FAST status, output value (MV) and alarm output maintain the output status that was there just before the FAST operation however time signal outputs depending on the program pattern. However the time error becomes bigger. <ul style="list-style-type: none"> ※ Limited to specifications with external signal output, time signal allotment and setting time. ▪ ADV operation progresses till the beginning of step number however the fast operation can progress up to the middle of program pattern (or step). |
|----------------|---|---|

If run operation is done, words indicating that run operation are displayed in 3 step snap display on the left side of the operation screen.

9-2-2 Procedure of program operation

When considering that program pattern and each parameter is set, the start/end procedure of program operation is as follows.

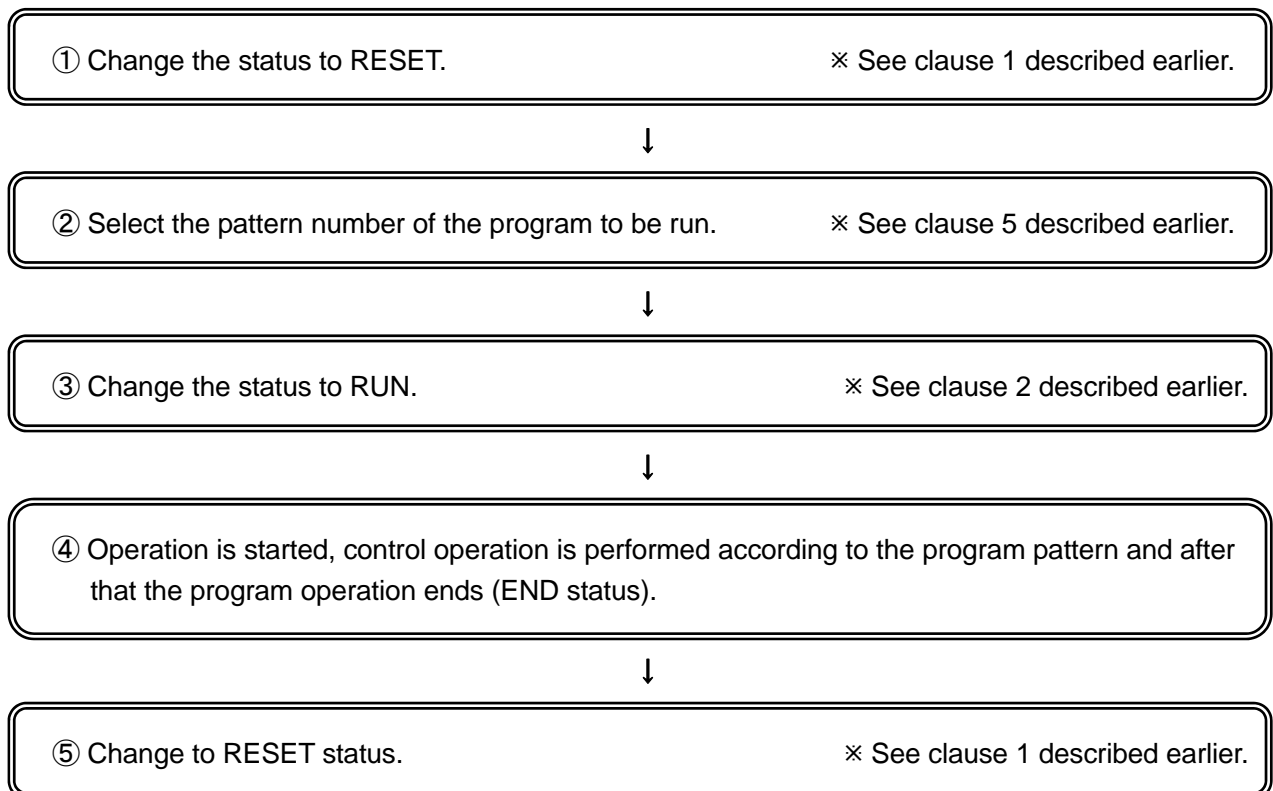

9-3. Trial operation

After the confirmations before operation is done, refer to the following and start the trial operation and do various confirmations. This procedure is an example of the most basic trial operation procedure. Add the confirmation contents depending on specifications of the controller, system configuration of finished product, control conditions etc.

① Start the power supply. Considering the safety, preferably make the output in RESET status when power supply is started as 0% or output as 0% in manual output operation such that the control output of the controller is 0%.



② Confirm that the instrument configuring the system that includes the controller also, is normal.



③ Confirm that all the signal levels (voltage value, current value, ON/OFF signal etc.) connected between the instrument configuring the system that includes the controller also, is normal.



④ When output format is current output format and thyristor regulator is connected as operation terminal, confirm the setting contents of thyristor. When output format is ON OFF servo type and motor is connected as operation terminal, do the operation terminal adjustment (FB zero span settings). Confirm the settings of thyristor regulator. In other output format also, confirm the operation terminal and do the adjustment as per the requirement.



⑤ Consider that the controller has a status of 0% output due to manual output operation. Output increases gradually, the operation of the operation terminal is equivalent to the output value and confirms that it is normal.



⑥ Set appropriate program pattern, start program operation by 'RUN' operation and switch over to automatic output operation and get the auto control status.



⑦ See the status for a while and if the control is stable then there is no problem. However if the control is unstable, adjust the parameters (PID etc.) of the controller. PID can be calculated automatically also by using the auto tuning function.





⑧ Confirm that operation (Alarm, external signal input etc.) with peripheral devices that are connected to the controller is normal.



⑨ Set various parameters of the controller as per the requirement.













⑩ After some time of starting the operation confirm the normality of final product that includes the controller and all the devices configuring the system.

9-4. Constant value operation

This controller is exclusively used for program operation and constant value operation can be performed by the following method. Use it as per the requirement.

| System | Description |
|--|--|
| 1. Switching from program operation status to constant value operation [Operation screen] | ① Set 'CONST' in 'control format' of mode 1. <ul style="list-style-type: none"> It becomes a constant value operation by using SV that was obtained when switching over to 'CONST'. For parameters other than SV also, control operation is done using parameters of mode 0. ② Set desired SV in 'Executing SV and time' of mode 0. <ul style="list-style-type: none"> When changing the SV, set the desired SV in 'Executing SV and time' of mode 0. For parameters other than SV also, set them in mode 0. ③ When returning to program operation, set 'PROGRAM', in 'Control format' of mode 1. <ul style="list-style-type: none"> When one switches to 'Program', program operation reopens. |
| 2. Switching from RESET status to constant value operation [Operation screen] | ① Set 'CONST' in 'control format' of mode 1. <ul style="list-style-type: none"> It becomes a constant value operation by using SV 'Executing SV and time' of mode 0. For parameters other than SV also, control operation is done using parameters of mode 0. ② Set desired SV in 'Executing SV and time' of mode 0. <ul style="list-style-type: none"> When changing the SV, set the desired SV in 'Executing SV and time' of mode 0. For parameters other than SV also, set using mode 0. ③ When returning to program operation, set 'PROGRAM', in 'Control format' of mode 1. <ul style="list-style-type: none"> When one switches to 'Program', it becomes a RESET status. |

9-5. Automatic output operation and manual output operation

| Operation method | Key operation and operation screen | Explanation |
|---|--|--|
| Automatic output operation (Auto output) | <p>[Key operation] In automatic output operation, switch to output display screen from operation screen, and click  key after clicking  key.</p> <p>[Operation screen]</p>  | <ul style="list-style-type: none"> Based on SV that is being executed and on the PV that is being measured, perform the control calculation, calculate the control output value and output it. Usual control operation is this automatic output operation. |
| Manual output operation (Manual output) | <p>[Key operation] In manual output operation, switch to output display screen from operation screen, and click  key after clicking  key.</p> <p>[Operation screen]</p>  | <ul style="list-style-type: none"> SV and PV output the control output value that is set irrespective of each other. If you want to switch to manual output operation, switch to output display screen from operation screen, and click the  key and the  key on the operation screen or switching can be done by external signal input also. Set the output value by  key/ key. Output range is within the output limit range. During automatic/manual switching, the output value does not change suddenly because of balance less bump less function. During manual output operation, 'M' is added before the word 'OUT' of the operation screen. In case of output 2 specifications, switching between automatic/manual can be done separately for operation screen of output 1 side and that of output 2 side. It is popularly called as manual output. |

9-6. Precautions during operation

9-6-1. Change in settings during operation

When changing the settings during operation any of the settings except partial setting screen can be changed. When settings cannot be changed during operation, error message is displayed during setting change operation. However changing the settings during control operation by using parameter, may adversely affect the control, hence take care.

An example, when a step was changed during execution is given below, please refer to it.

① When SV1 is changed

An example where in SV1 (setting value) of step n is changed to SV2 is given. In case of this example, please understand that there was a setting value operation in step n+1 before change, however there is no setting value operation in step n+1 after change.

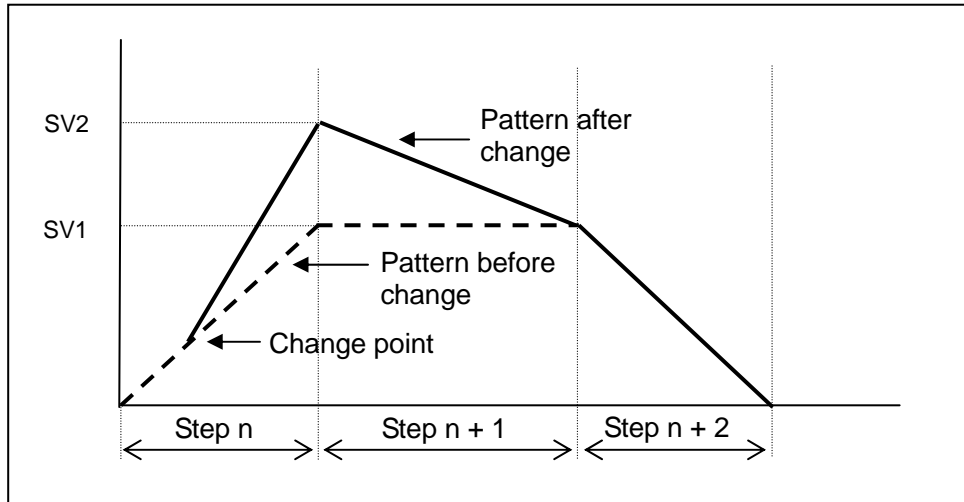

② When TIME is changed

An example wherein TIME (required time) of step n is changed just a little by T is given. On a whole there is a shift of only T minutes.

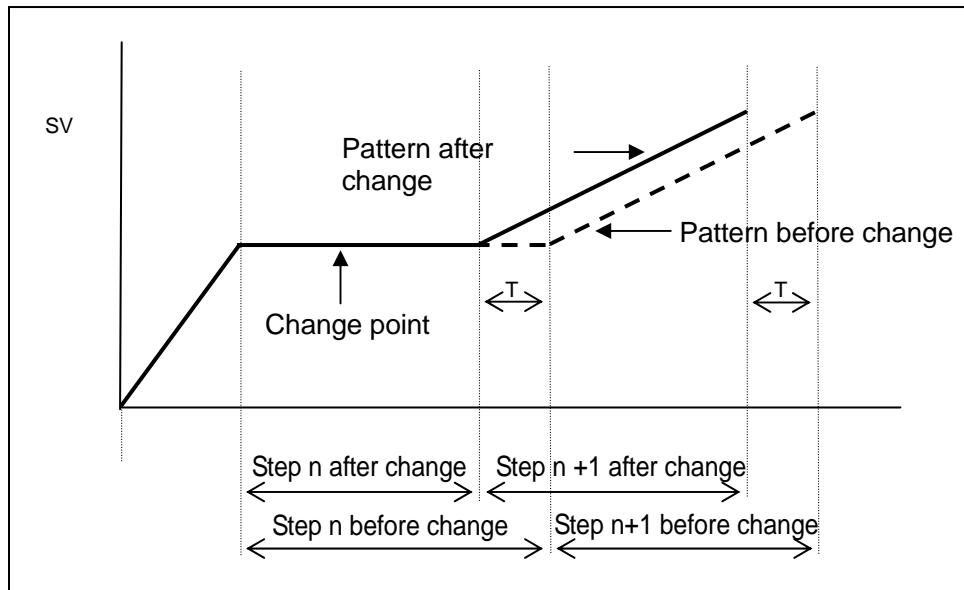

9-6-2. Precautions when power supply is started

1. P (proportion) operation when starting the power supply

Even though the settings of PID control are done, only the initial control operation at the time of power supply becomes the P (proportion) operation. As a result, due to the conditions the output value becomes very big momentarily during the power supply, hence take care.

2. Countermeasures against the erroneous output during power supply

During the power supply, until the controller starts normally, output related signals are sometimes momentarily output. Implement the countermeasures against erroneous output as per the requirement by using external circuit.

3. Precautions in case of momentary power cut off

When power supply is started again, operation status is depends on the settings of 'Operation when power supply is started' of mode 1.

When 'CONTINUE' is selected, one returns to the status at the time of power supply cut off. In other words, if status is RUN at the time of power cut off then it remains RUN and if it is READY at that time it remains READY. When 'RESET' is selected, even if the status is 'RUN' in the setting screen and external signal input, the status is always 'RESET'. At that time if change it to RUN again in the setting screen and external signal input, the status becomes RUN. In this case the status becomes RUN from step number 00. Especially when using external signal input take care about the sequence.

Even though the power supply cut off/start does not take place due to operation by the customer or due to final product sequence, there is a temporary power cut off/start due to some reason, and even when the controller detects the power supply cut off/start, the operation is performed based on the settings of 'Operation at the time of starting the power supply' of mode 1. For example if a good quality power supply is not used, if 'RESET' is selected when a momentary power cut off etc. takes place, unknowingly the status becomes 'RESET' status, hence take care. Do not select 'RESET' as it adversely affects the entire system of the final product when power supply is not stable.

The momentary power cut off and detection time for this product is approximately 200mS (Power supply voltage:0%) or more.



Precautions

- ① Take care while changing the settings during operation. Control may sometimes be adversely affected due to parameters.
- ② Use a good quality and stable power supply. Due to noise or momentary power cut off the controller may sometimes be adversely affected and it may sometimes malfunction unexpectedly.

10. Detailed explanation of main functions

10-1 Measurement range

The controller is a universal input type or a 4-wire resistance thermometer type and various measurement ranges. From among them, select the appropriate measurement range from the sensor and the scale range that is to be actually used. For thermocouple and resistance thermometer, confirm the standards and then select the measurement range. Especially 'Pt100Ω' system of resistance thermometer has three types of standards hence take care.

Displayed measurement range which is set at [measurement range] of mode 5 may be not in order.

[Universal]

| No. | Measurement range | Scale range (°C) | Scale range (K) | No. | Measurement range | Scale range (°C) | Scale range (K) | | |
|-----|-------------------|------------------|------------------|-----------------|------------------------|------------------------|-----------------|-----------------|----------------|
| 01 | Thermocouple | B | 0.0 to 1820.0 | 273.0 to 2093.0 | 31 | Direct current voltage | 10mV | ±10mV | |
| 02 | | R1 | 0.0 to 1760.0 | 273.0 to 2033.0 | 32 | | 20mV | ±20mV | |
| 03 | | R2 | 0.0 to 1200.0 | 273.0 to 1473.0 | 33 | | 50mV | ±50mV | |
| 04 | | S | 0.0-1760.0 | 273.0 to 2033.0 | 34 | | 100mV | ±100mV | |
| 05 | | K1 | -200.0 to 1370.0 | 73.0 to 1643.0 | 35 | | 5V | ±5V | |
| 06 | | K2 | 0.0 to 600.0 | 273.0 to 873.0 | 37 | | 10V | ±10V | |
| 07 | | K3 | -200.0 to 300.0 | 73.0 to 573.0 | 36 | Direct current | 20mA | 0 to 20mA | |
| 08 | | E1 | -270.0 to 1000.0 | 3.0 to 1273.0 | | | | | |
| 09 | | E2 | 0.0 to 700.0 | 273.0 to 973.0 | | | | | |
| 10 | | E3 | -270.0 to 300.0 | 3.0 to 573.0 | | | | | |
| 11 | | E4 | -270.0 to 150.0 | 3.0 to 423.0 | | | | | |
| 12 | | J1 | -200.0 to 1200.0 | 73.0 to 1473.0 | Resistance thermometer | JPt100Ω1 | -200.0 to 649.0 | 73.0 to 922.0 | |
| 13 | | J2 | -200.0 to 900.0 | 73.0 to 1173.0 | | 41 | JPt100Ω2 | -200.0 to 400.0 | 73.0 to 673.0 |
| 14 | | J3 | -200.0 to 400.0 | 73.0 to 673.0 | | 42 | JPt100Ω4 | -200.0 to 200.0 | 73.0 to 473.0 |
| 15 | | J4 | -100.0 to 200.0 | 173.0 to 473.0 | | 44 | JPt100Ω5 | -100.0 to 100.0 | 173.0 to 373.0 |
| 16 | | T1 | -270.0 to 400.0 | 3.0 to 673.0 | | 45 | QPt100Ω1 | -200.0 to 649.0 | 73.0 to 922.0 |
| 17 | | T2 | -200.0 to 200.0 | 73.0 to 473.0 | | 46 | QPt100Ω2 | -200.0 to 400.0 | 73.0 to 673.0 |
| 18 | | WRe5-26 | 0.0 to 2310.0 | 273.0 to 2583.0 | | 47 | QPt100Ω4 | -200.0 to 200.0 | 73.0 to 473.0 |
| 19 | | W-WRe26 | 0.0 to 2310.0 | 273.0 to 2583.0 | | 49 | QPt100Ω5 | -100.0 to 100.0 | 173.0 to 373.0 |
| 20 | | NiMo-Ni | -50.0 to 1410.0 | 223.0 to 1683.0 | | 50 | QPt100Ω5 | -100.0 to 100.0 | 173.0 to 373.0 |
| 21 | | CR-AuFe | 0.0 to 280.0 K | 0.0 to 280.0 | | 51 | JPt50Ω | -200.0 to 649.0 | 73.0 to 922.0 |
| 22 | | N | 0.0 to 1300.0 | 273.0 to 1573.0 | | 53 | Pt100Ω1 | -200.0 to 850.0 | 73.0 to 1123.0 |
| 23 | | PR5-20 | 0.0 to 1800.0 | 273.0 to 2073.0 | | 54 | Pt100Ω2 | -200.0 to 400.0 | 73.0 to 673.0 |
| 24 | | PtRh40-20 | 0.0 to 1880.0 | 273.0 to 2153.0 | | 56 | Pt100Ω4 | -200.0 to 200.0 | 73.0 to 473.0 |
| 25 | | Plati II 1 | 0.0 to 1390.0 | 273.0 to 1663.0 | | 57 | Pt100Ω5 | -100.0 to 100.0 | 173.0 to 373.0 |
| 26 | | Plati II 2 | 0.0 to 600.0 | 273.0 to 873.0 | | | | | |
| 27 | | U | -200.0 to 400.0 | 73.0 to 673.0 | | | | | |
| 28 | | L | -200.0 to 900.0 | 73.0 to 1173.0 | | | | | |

[4-wire resistance thermometer]

| No. | Measurement range | Scale range (°C) | Scale range (K) | No. | Measurement range | Scale range (°C) | Scale range (K) | | |
|-----|------------------------|------------------|-----------------|----------------|-------------------|------------------------|-----------------|-----------------|----------------|
| 41 | Resistance thermometer | JPt100Ω1 | -200.0 to 649.0 | 73.0 to 922.0 | 50 | Resistance thermometer | QPt100Ω5 | -100.0 to 100.0 | 173.0 to 373.0 |
| 42 | | JPt100Ω2 | -200.0 to 400.0 | 73.0 to 673.0 | 51 | | JPt50Ω | -200.0 to 649.0 | 73.0 to 922.0 |
| 44 | | JPt100Ω4 | -200.0 to 200.0 | 73.0 to 473.0 | 52 | | Pt-Co | 4.0 to 374.0 K | 4.0 to 374.0 |
| 45 | | JPt100Ω5 | -100.0 to 100.0 | 173.0 to 373.0 | 53 | | Pt100Ω1 | -200.0 to 850.0 | 73.0 to 1123.0 |
| 46 | | QPt100Ω1 | -200.0 to 649.0 | 73.0 to 922.0 | 54 | | Pt100Ω2 | -200.0 to 400.0 | 73.0 to 673.0 |
| 47 | | QPt100Ω2 | -200.0 to 400.0 | 73.0 to 673.0 | 56 | | Pt100Ω4 | -200.0 to 200.0 | 73.0 to 473.0 |
| 49 | | QPt100Ω4 | -200.0 to 200.0 | 73.0 to 473.0 | 57 | | Pt100Ω5 | -100.0 to 100.0 | 173.0 to 373.0 |

[Standard list]

K, E, J, T, R, S, B, N: IEC584 (1977,1982), JIS C 1602-1995, JIS C 1605-1995
 WRe5-WRe26, W-WRe26, NiMo-Ni, Platinel II, CR-AuFe, PtRh40-PtRh2: ASTM Vo1.14.03
 U, L: DIN43710-1985
 Pt100: IEC751 (1995), JIS C 1604-1997
 QPt100: IEC751 (1983), JIS C 1604-1989, JIS C 1606-1989
 ※QPt100 is also called old PT100.
 JPt100: JIS C 1604-1981, JIS C 1606-1986
 JPt50: JIS C 1604-1981

10-2 .Linear scale

If linear input (DC voltage and current) is selected, initial value of linear scale and measurement scope is as follows.

| Measurement range | Scale range | Measurement scope (Initial value) | Linear scale (Initial value) |
|-------------------|--------------------|-----------------------------------|------------------------------|
| 31 10mV | - 10.0 to 10.0 mV | 0.00 to 10.00 mV | 0.0 to 2000.0 |
| 32 20mV | - 20.0 to 20.0 mV | 0.00 to 20.00 mV | 0.0 to 2000.0 |
| 33 50mV | - 50.0 to 50.0 mV | 0.00 to 50.00 mV | 0.0 to 2000.0 |
| 34 100mV | -100.0 to 100.0 mV | 0.0 to 100.0 mV | 0.0 to 2000.0 |
| 35 5V | -5.0 to 5.0 V | 0.000 to 5.000 V | 0.0 to 2000.0 |
| 37 10V | -10.0 to 10.0V | 0.000 to 10.000 | 0.0 to 2000.0 |
| 36 20mA | 0.0 to 20.0 mA | 4.00 to 20.00 mA | 0.0 to 2000.0 |

Setting procedure is as follows.

- ① For 'measurement scope' of mode 5, set the minimum value and the maximum value of the analog signal that is actually input from the sensor.
- ② For 'linear scale' of mode 5, after confirming how to display that minimum value and maximum value, set the decimal point position and lower limit and upper limit of the scale.
- ③ For example, for 4 to 20 mA if you want to display 0.00 to 100.00, the settings are as follows.
 - Measurement scope : 4.000 (minimum value) to 20.000 (Maximum value).
 - Linear scale : DOT2.
0.00 (Lower limit) to 100.00 (Higher limit).

10-3. Alarm mode

Following are the types of alarm formats.

- ① PV (Measurement value) alarm
 - PV (Absolute value alarm) : PV alarm due to alarm setting value.
 - DV (Deviation alarm) : SV+PV alarm depending to alarm setting value.
 - ADV (Absolute value deviation alarm) : SV±PV alarm due to alarm setting value.
※ Set integer number (absolute value) for alarm value.
- ② SV (Setting value) alarm
 - SV (Setting value alarm) : SV alarm due to alarm setting value.
- ③ MV (Output value) alarm
 - MV (Output value alarm) : MV alarm due to alarm setting value.
※ In case of output 2 specifications, it becomes the output value (MV1) alarm of output 1.
- ④ Control related alarms
 - CT (Heater snapping wire alarm) : CT measurement value alarm due to alarm setting value.
※ Only specifications with heater snapping wire alarm can be selected.
- ⑤ FAIL (Abnormal) alarm
 - FAIL (Fail alarm) : RJ data abnormal, A/D conversion abnormal.
※ Setting value does not exist.
- ⑥ Timer
 - TIMER : Timer combined with external signal input.
※ Only specifications with external signal input can be selected.
- ⑦ Wait time alarm
 - WAIT (Wait alarm) : Real temperature compensation.

In addition select the following conditions in alarm format ① to ③, mentioned above.

- H (High limit alarm) : Alarm turns ON if alarm setting value is exceeded.
- L (Low limit alarm) : Alarm turns ON if alarm setting value is less.
- HW (Wait high limit alarm) : In a system that has wait function in high limit alarm, keep the alarm ON in wait status until it once enters the normal range. When RUN is performed from RESET status or ADV (stepping) is performed, it becomes wait status.
- LW (Wait low limit alarm) : In a system that has wait function in low limit alarm, keep the alarm ON in wait status until it once enters the normal range. When RUN is performed from RESET status or ADV (stepping) is performed, it becomes wait status.
- HK (Maintenance high limit alarm) : In a system that has maintenance function in high limit alarm, the alarm ON status is maintained from the time when alarm is switched ON to the time when it is cancelled.
※ Alarm is cancelled by alarm output cancellation, switching to RESET from program operation, or OFF/ON of power.
- LK (Maintenance low limit alarm) : In a system that has maintenance function in low limit alarm, the alarm ON status is maintained from the time when alarm is switched ON to the time when it is cancelled.
※ Alarm is cancelled by alarm output cancellation, switching to RESET from program operation, or OFF/ON of power.
- HWK (Wait maintenance high limit alarm): It is a system that has wait function and maintenance function in high limit alarm.
- LWK (Wait maintenance low limit alarm) : It is a system that has wait function and maintenance function in low limit alarm.

*Alarm calculation is performed in program operation and constant value operation, not in RESET.

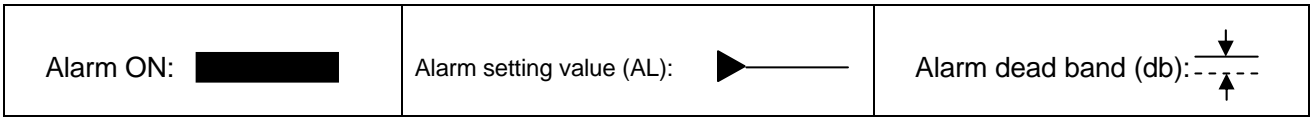

| | |
|--|---|
| <p style="text-align: center;">[PV-H(Absolute value high limit alarm)]</p> <p style="text-align: center;">Alarm ON </p> <p style="text-align: center;">$AL < PV: ON, AL - db < PV \leq AL: KEEP, PV \geq AL + db: OFF$</p> | <p style="text-align: center;">[PV-L(Absolute value low limit alarm)]</p> <p style="text-align: center;">Alarm ON </p> <p style="text-align: center;">$AL > PV: ON, AL \leq PV < AL + db: KEEP, PV \leq AL - db: OFF$</p> |
| <p style="text-align: center;">[PV-HW (Wait absolute value high limit alarm)]</p> <p style="text-align: center;">Alarm ON </p> <p style="text-align: center;">* AL: OFF until it once enters the normal range</p> <p style="text-align: center;">$AL < PV: ON, AL - db < PV \leq AL: KEEP, PV \geq AL + db: OFF$</p> | <p style="text-align: center;">[PV-LW (Wait absolute value low limit alarm)]</p> <p style="text-align: center;">Alarm ON </p> <p style="text-align: center;">* AL: OFF until it once enters the normal range</p> <p style="text-align: center;">$AL > PV: ON, AL \leq PV < AL + db: KEEP, PV \geq AL + db: OFF$</p> |
| <p style="text-align: center;">[PV-HK (Maintenance absolute value high limit alarm)]</p> <p style="text-align: center;">Alarm ON </p> <p style="text-align: center;">* AL: ON until alarm is cancelled after AL: ON</p> <p style="text-align: center;">$AL < PV: ON, AL - db < PV \leq AL: KEEP, PV \leq AL - db: OFF$</p> | <p style="text-align: center;">[PV-LK (Maintenance absolute value low limit alarm)]</p> <p style="text-align: center;">Alarm ON </p> <p style="text-align: center;">* AL: ON until alarm is cancelled after AL: ON</p> <p style="text-align: center;">$AL > PV: ON, AL \leq PV < AL + db: KEEP, PV \geq AL + db: OFF$</p> |
| <p style="text-align: center;">[PV-HWK (Wait maintenance absolute value high limit alarm)]</p> <p style="text-align: center;">Alarm ON </p> <p style="text-align: center;">* AL: OFF until it once enters the normal range</p> <p style="text-align: center;">* AL: ON until alarm is cancelled after AL: ON</p> <p style="text-align: center;">$AL < PV: ON, AL - db < PV \leq AL: KEEP, PV \leq AL - db: OFF$</p> | <p style="text-align: center;">[PV-LWK (Wait maintenance absolute value low limit alarm)]</p> <p style="text-align: center;">Alarm ON </p> <p style="text-align: center;">* AL: OFF until it once enters the normal range</p> <p style="text-align: center;">* AL: ON until alarm is cancelled after AL: ON</p> <p style="text-align: center;">$AL > PV: ON, AL \leq PV < AL + db: KEEP, PV \geq AL + db: OFF$</p> |

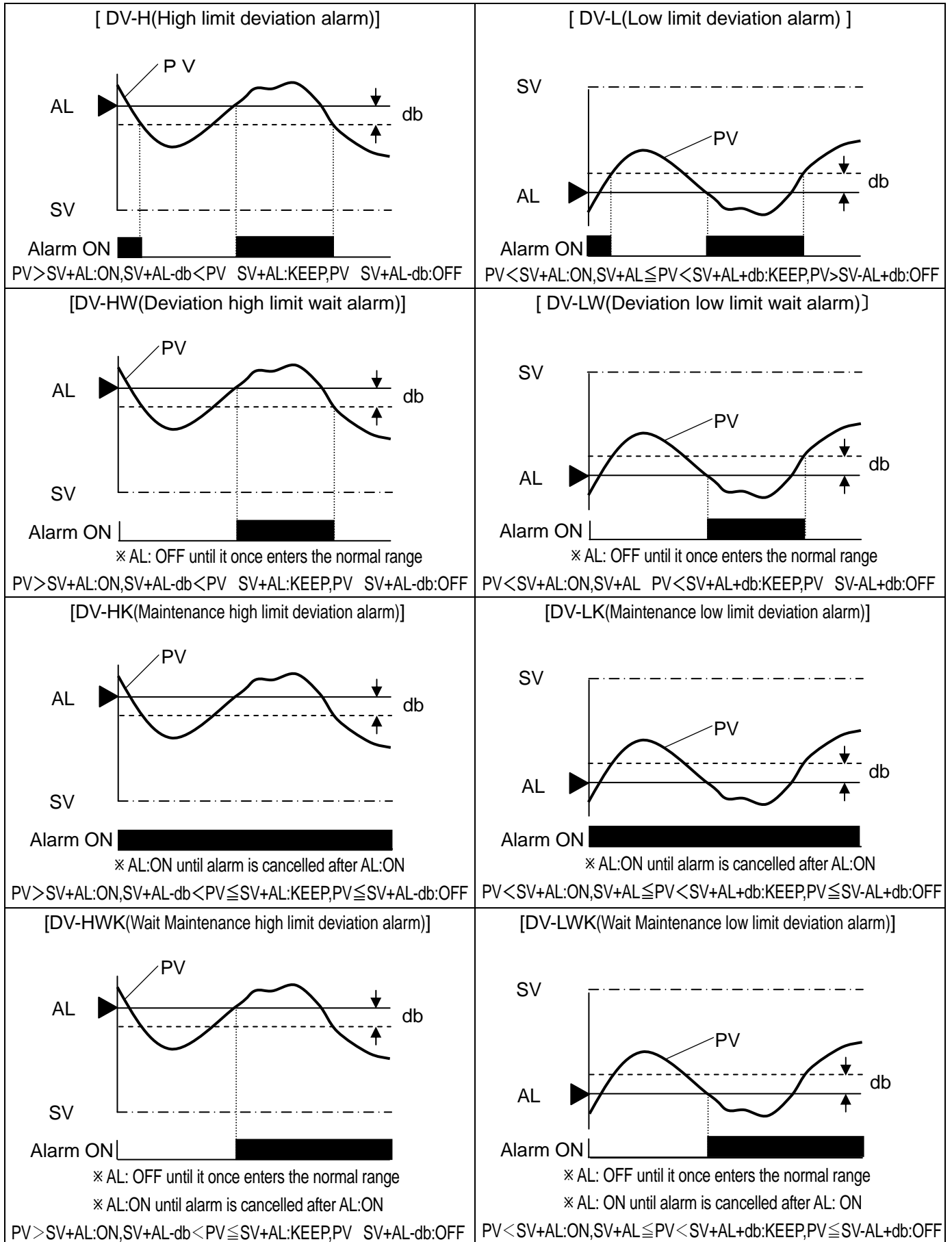

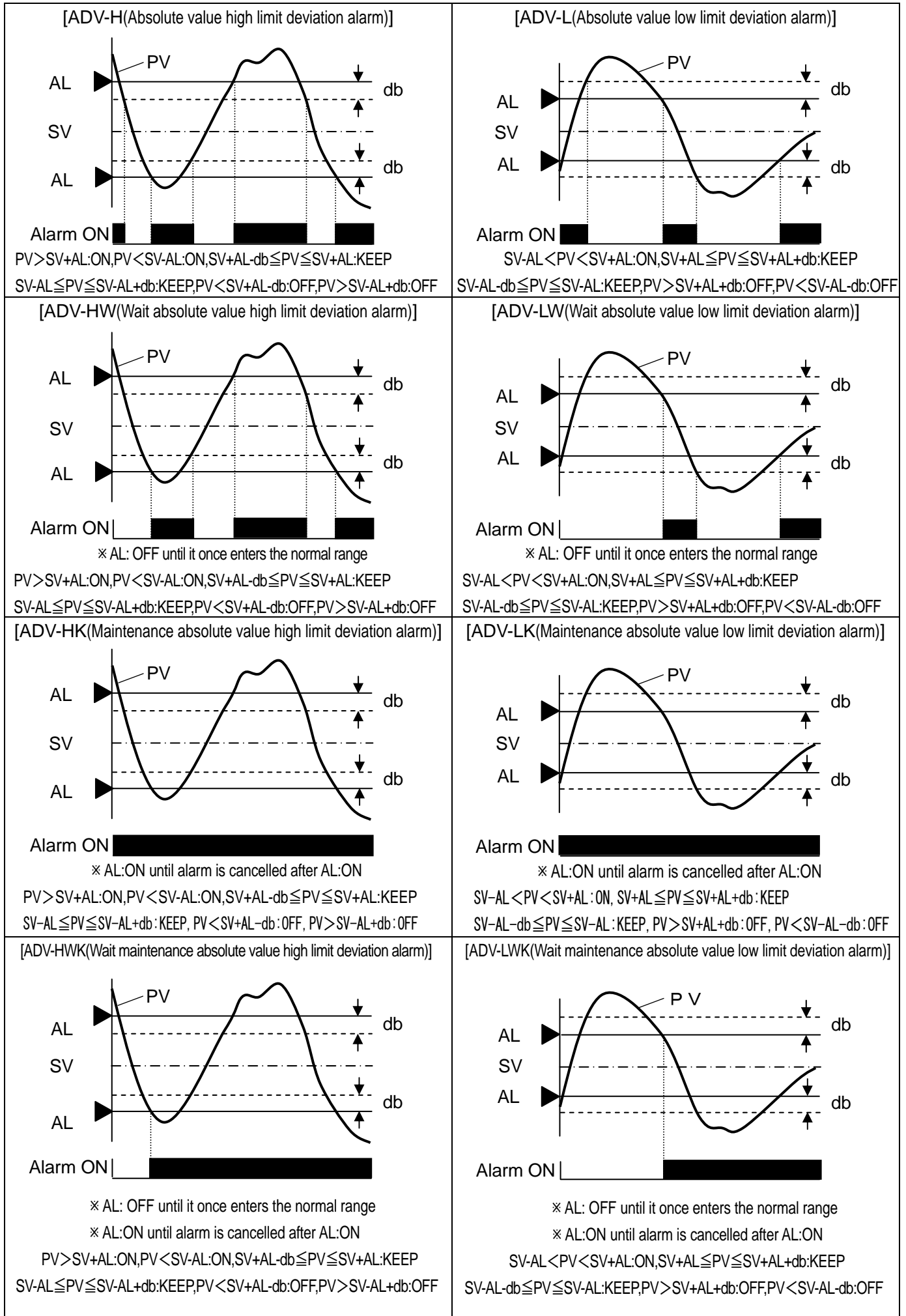

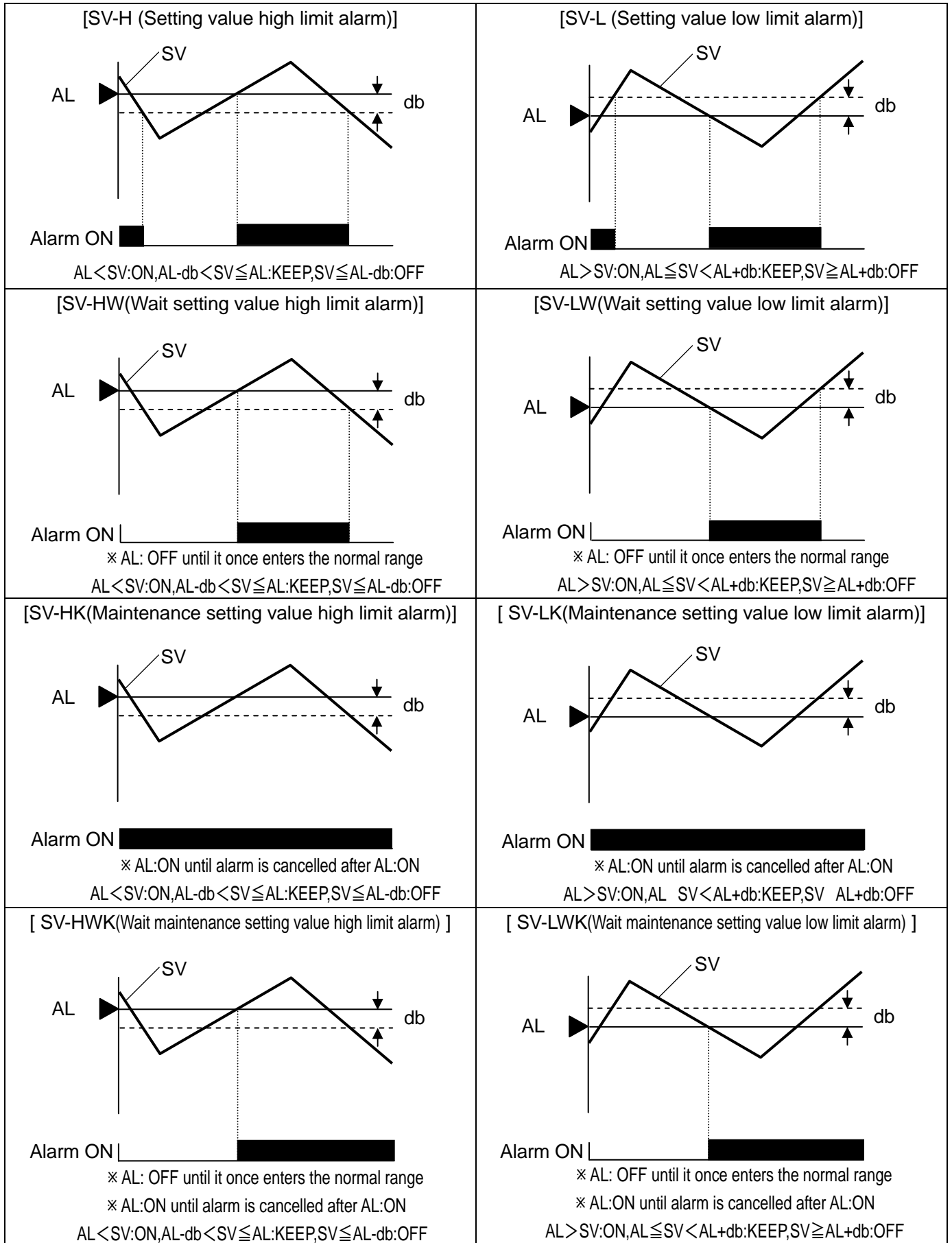

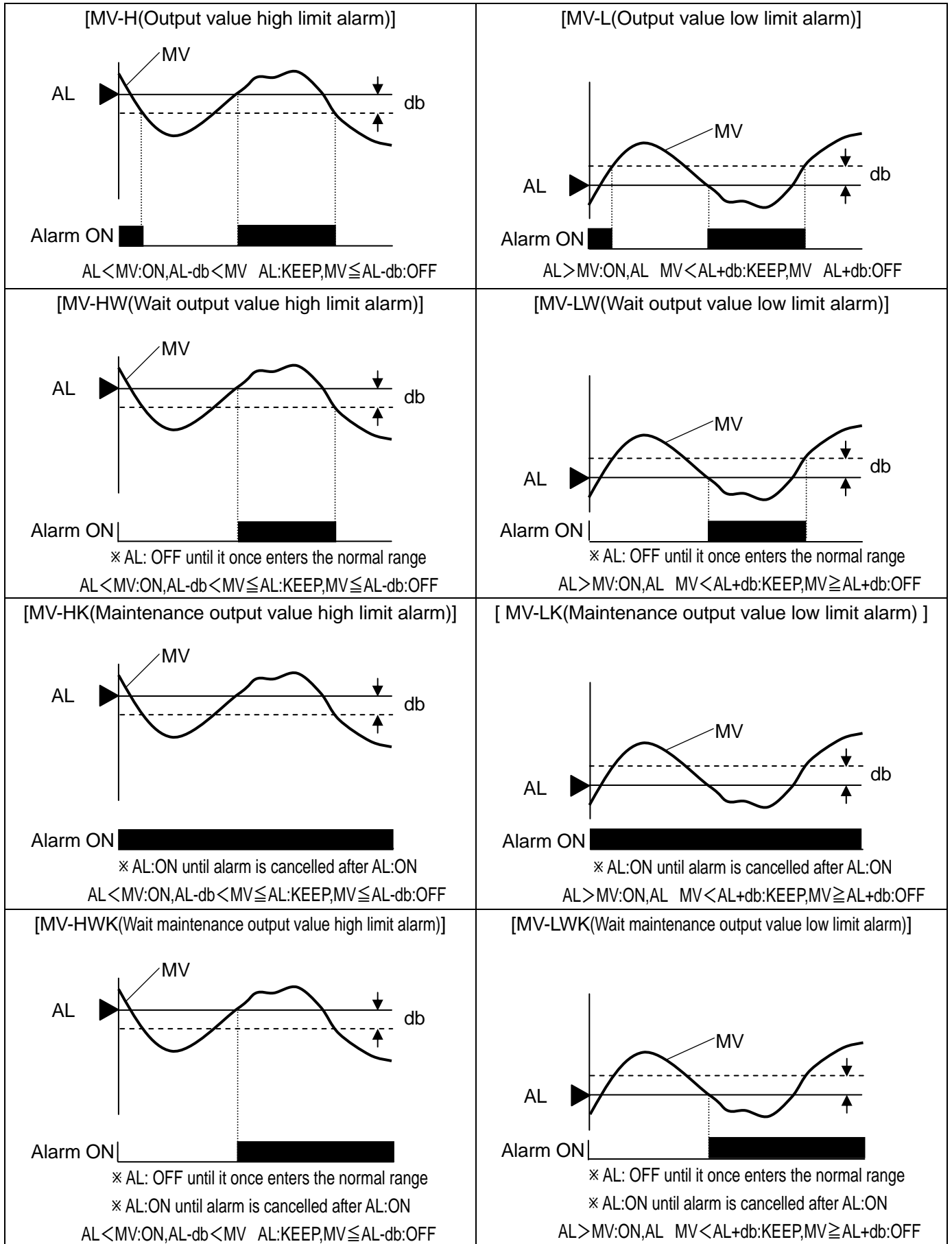

[CT(Heater snapping wire alarm)]

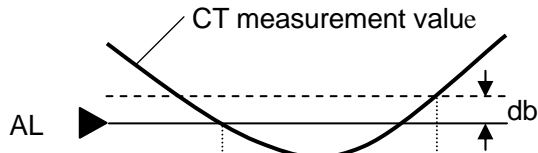

Alarm ON |
 $AL > CT: ON, AL \leq CT < AL + db: KEEP, CT \geq AL + db: OFF$

- ① Only specifications with heater snapping wire alarm can be selected.
- ② After startup the initial CT value is '- - -A'. At that time alarm cannot be judged.
- ③ When pulse output is switched OFF, final value when it was ON is displayed.
- ④ As this alarm considers the delayed time for which the current flows in the heater, the output of the controller is measured after approximately 300mS onwards after it is switched ON and judgment is done. Accordingly alarm judgment is not done when time elapsed is less than approximately 300mS after the output of the controller is switched ON.
- ⑤ CT display is valid between 5A to 100A. Current value other than that is not accurately displayed.
- ⑥ When both outputs are pulse type, alarm is judged by output 1.

[TIMER]

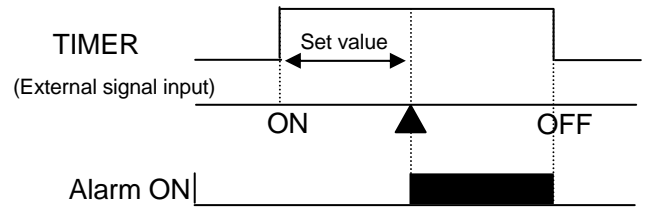

- ① Only specifications with external signal input can be selected.
- ② Layout of timer and external signal input is as follows.
 - AL1:TIMER1
 - AL2:TIMER2
 - AL3:TIMER3
 - AL4:TIMER4
- ③ Time unit of alarm setting value is s (second).

[WAIT (Wait alarm)]

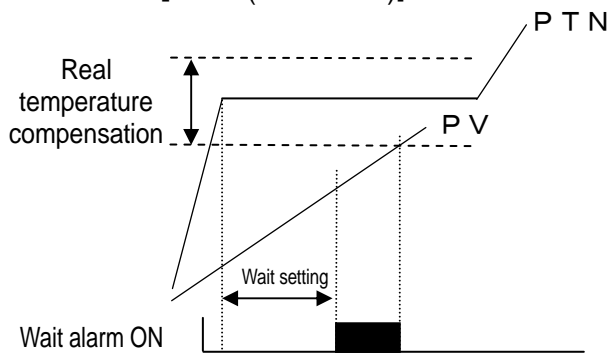

- ① Judged by end time of step with real temperature compensation.
- ② When real temperature compensation time is longer than wait alarm value, wait alarm is outputted.
- ③ WAIT of upper display blinks during wait alarm. WAIT is displayed on setting screen of alarm value because alarm value is not used during WAIT setting

10-4. Auto tuning

Auto tuning (AT) is a function that automatically calculates PID constant.

There are four types of auto tunings namely AT1 to AT4 as shown below.

① AT1

- It is an auto tuning for output 1.
- It can be executed in RUN status (excluding program end status) or in constant value control status.
- Execute auto tuning by using SV when AT1 is set.
- PID calculated by using AT1, is registered in PID of PID number that is executing.

② AT2

- It is an auto tuning for output 1.
- It can be executed in RESET status (excluding constant value control status).
- 8 types of SV for AT2 can be set beforehand and 8 types of PIDs can be calculated according to those.
- PID calculated using AT2, is registered respectively in PID numbers from 1 to 8. ON/OFF of AT can be set for each of the 8 types separately and AT execution of only arbitrary numbers is also possible.

③ AT3

- It is an auto tuning for output 1.
- It can be executed in RESET status (excluding constant value control status).
- 8 types of SV for AT3 can be set beforehand and 8 types of PIDs can be calculated according to those.
- PID calculated using AT3, is registered respectively in PID numbers from 9-1 to 9-8. ON/OFF of AT can be set for each of the 8 types separately and AT execution of only arbitrary numbers is possible. ON/OFF of AT can be set for each of the 8 types separately and AT execution of only arbitrary numbers is also possible.

④ AT4

- It is an auto tuning for output 2.
- It can be executed in RUN status (excluding program end status) or in constant value control status.
- Execute auto tuning by using SV when AT4 is set.
- PID calculated by using AT4, is registered in output 2 PID

In case of output 2 specifications, MV (output value) on output 2 side during non executable AT is continued control.

Sometimes even on starting the auto tuning operation normally, PID is not requested. Conditions when it is not requested are as follows. In that case PID constants are not changed and the original PID constants remain.

- When response is delayed too much, when it does not end even after around six hours of auto tuning operation.
- When the value of P calculated by auto tuning is less than 0.1% or more than 1000%.
- When the value of I calculated by auto tuning is less than 1 second.
- When the value of D calculated by auto tuning is less than 1 second.

10-5. PID control

PID is the most generic control algorithm that consists of three operations namely P (Proportion), I (Integration) and D (Differentiation).

① P operation

- It is the basic operation of PID control. It largely affects the responsiveness and the stability. Offset occurs only in proportion operation.
- If P is increased, the amplitude of PV (measurement value) becomes less and the stability improves however the responsiveness deteriorates.
- By setting $P=0\%$ two-position control action takes place.





② I operation

- Offset due to P operation can be eliminated however as the phase is delayed stability deteriorates.
- If I is reduced (integral operation is strengthened), responsiveness improves, over shoot increases.
- Setting value '0' is equivalent to ∞ (infinity).

③ D operation

- It compensates the time that is wasted and delay in phase due to delayed elements. However as gain in high frequency area increases, there is a limit for the strength.
- If D is increased, responsiveness increases for a large deviation, however for quick periodic deviations stability deteriorates.
- '0' of the settings value is equivalent to OFF.
- The setting value of D, is $1/6^{\text{th}}$ to $1/4^{\text{th}}$ the setting value of I and it is generic.

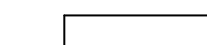
Collectively the PID operation is as follows.

| | P (Proportion) operation | I (Integration) operation | D (Differentiation) operation |
|--------|---|---|--|
| Input |  |  |  |
| Output |  |  |  |

The controller has 2 types of PID control algorithms installed, either of it can be selected.

① POSITION

- Position type PID system.
- Comparatively, response is valid for control target.

② VELOCITY

- Speed type PID system.
- Comparatively, response is valid for quick control target.

For theory and details of PID control see its special literature.

10-6. Automatic PID switching system

For execution number system, automatic PID switching system makes maximum 8 divisions of SV section in which measurement scope is considered as maximum range and registers a PID in each of that SV section beforehand. As a result this function operates by using the PID that is registered in each of those SV sections when any of the SV is executed.

Hence once the PID numbers from 9-1 to 9-8 are set, for SV section and automatic PID switching system, even though the SV is changed, there is no trouble of changing the PID accordingly.

Automatic PID switching system is a function of PID for output 1 only. There is only one type of PID for output 2.

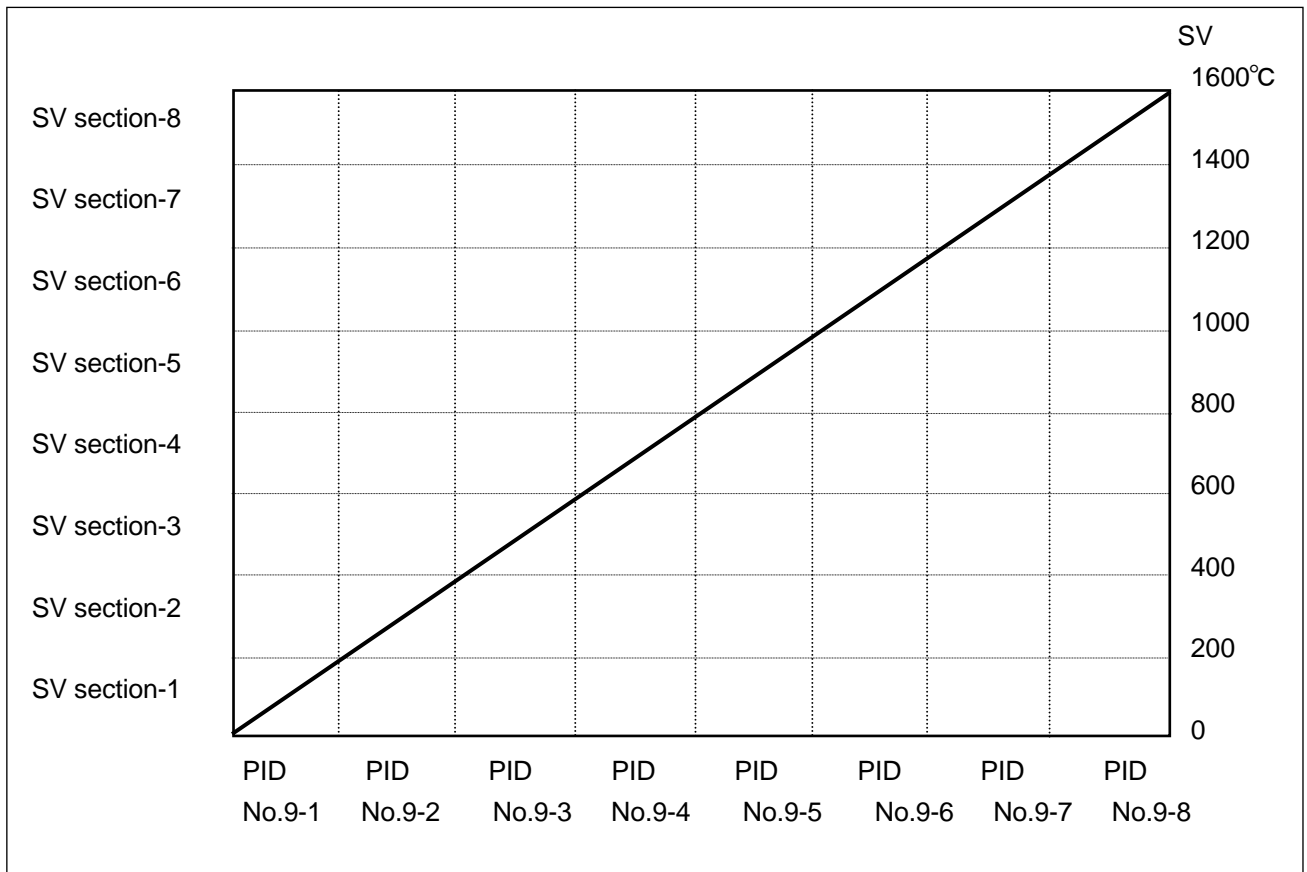

Refer to the above when reading the explanation of setting method.

① Setting SV section

- Confirm the setting range and SV range and decide in how many parts is the SV section to be divided.
- Set SV section in 'SV section for automatic PID' of mode 3.

※ In the above example, measurement scope is 0 to 1600°C, and for a span of 1600°C eight sections each of 200 are done and SV section is set.

② Setting PID

- In 'PID 16 types' of mode 3, PID numbers from 9-1 to 9-8 according to the SV sections, are set.

※ PID can be requested from auto tuning also. Auto tuning that requests PID numbers from 9-1 to 9-8 is AT3.

③ Selecting PID system

- Select 'No. 9' as the PID No. in 'PID No. and Alarm No.' of mode 2.

10-7. Actuator adjustment of ON-OFF servo type

If the output format is ON-OFF servo type, the controller and the actuator (motor etc.) should be adjusted. Do the adjustment basically by auto adjustment. Fine adjustment can be done manually also, however if you are using it for the first time, use the automatic adjustment first and then the manual fine adjustment. When auto adjustment is not performed, output value of output display screen and feedback value have a margin of error.

1. Auto adjustment

① Initializing the setting value

- Before the adjustment, consider the setting value of 'FB dead band' of mode 4 as the initial value.
- For initial value, the dead band becomes 1.0%.
- Other than that for output in the range of 0-100%, confirm each parameter.

② Zero span adjustment

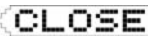
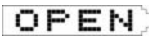
- Select 'START' in 'FB tuning' of mode 4, click  key and start FB tuning, and then adjusted data of feedback which is displayed at output display screen is initialized.
- The actuator automatically runs on  side and  side and calculates the zero span value automatically.
- When FB tuning is completed, return to 'END'.
- The automatically calculated zero span value is automatically registered in 'FB zero span' of mode 4 hence confirm it.

③ Dead band adjustment (Gain adjustment)

- See ⑤ of "Manual adjustment".



If the movement of actuator is delayed too much, auto calculation by 'FB tuning' is not possible. In that case after a fixed period return to 'END' and zero span value is not registered.

2. Manual adjustment

① Initializing the setting value

- Before the adjustment, return the setting value of 'FB dead band' and 'FB zero span' of mode 4 to initial value.
- Initial values are zero is 0.0%, span is 100.0% and dead band is 1.0%.
- Other than that for output in the range of 0-100%, confirm each parameter.

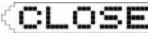
② Zero adjustment

- Perform manual output operation (manual output) and set the output value to 0.0%.
- Actuator scales out on  side.
- Increase the output value by 0.1% every time and request an output value that erases  display.

③ Span adjustment

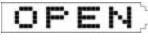
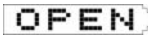
- Similarly the output value is set to 100.0%.
- Actuator scales out on  side.
- Decrease the output value by 0.1% every time and request an output value that erases  display.

④ Registering zero span value

- Set the output value requested in  and , in 'FB zero span' of mode 4 respectively.

⑤ Dead band adjustment (Gain adjustment)

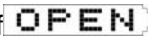
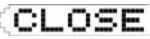
- Successively, similarly set the output value to 50.0%.
- Increase the setting value a little every time in 'FB dead zone' of mode 4 and request a setting value that erases both the displays of  and  of the operation screen.
- Perform a trial operation, increase the setting value little by little until the range where there is no error in controllability and set the greatest value as the settings value of final 'FB dead band'.

10-8. Output 2

Output 2 system of the controller is made for heating and cooling and has two types of systems PID system and SPRIT system.

Understand each system properly and then select the appropriate one.

1. PID system

- It is a system for setting PID of output 2 and gap between output 1 and output 2.
- Usually, consider output 1 as heating operation and set 'direct/reverse controlling operation' of mode 4 as 'REVERSE' and consider output 2 as cooling operation and set controlling operation as 'DIRECT'.
- Gap is as shown in the figure below. It is called the gap between SV and 0% of output 2 (For proportion band).
- When both output 1 and output 2 are $PV=SV$, if you want output to be 50% (When I operation and D operation are not included), it can be done by requesting a gap $G (\%) = -P/2$ (P: Proportion band of output 2, output 2 is direct operation).

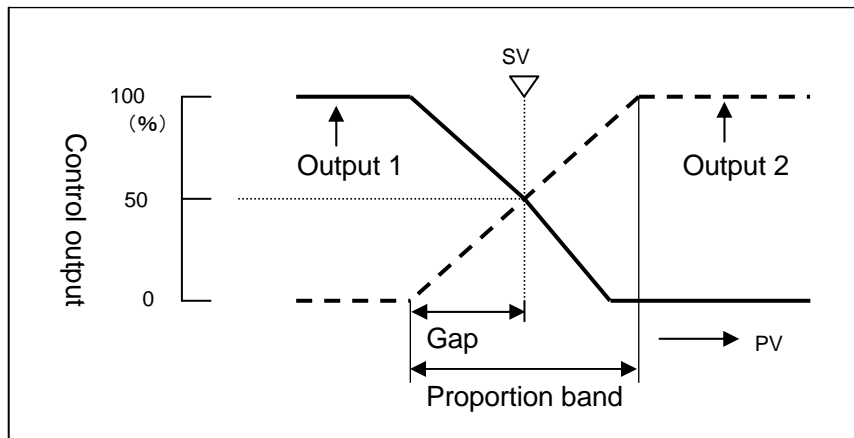

2. SPRIT system

- In matching box calculation system, PID calculation result of output 1 is considered as base and the operation shown in the following figure takes place.
- Setting range is 0-60% for DIRECT and 40-100% for REVERSE.
- When output 1 is set 'REVERSE' in setting of 'direct/reverse controlling operation' of mode 4, output 2 performs 'REVERSE' operation. When output 1 is set 'DIRECT', output 2 performs 'REVERSE'.

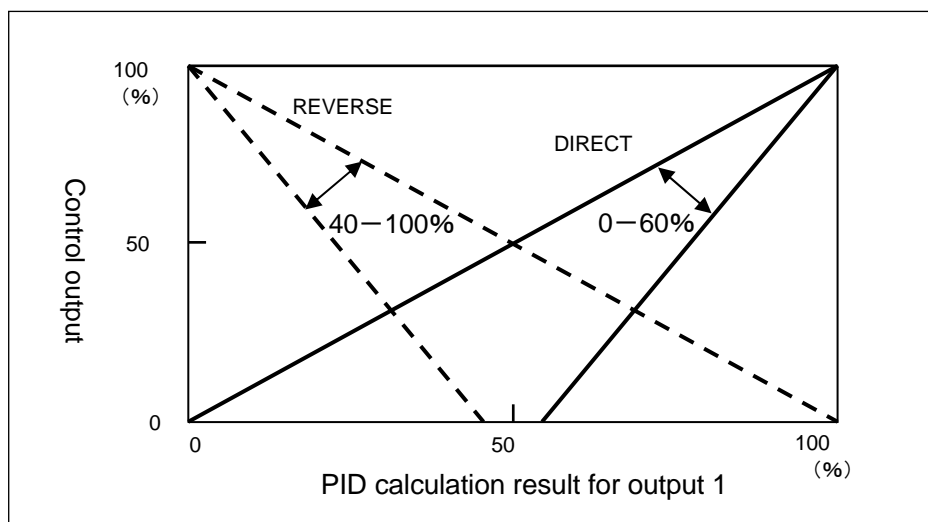

10-9. Transmission signal output

It is a function that selects one type from PV (measurement value), SV (measurement value), MV1 (Output value 1), MV2 (Output value 2), MFB (feedback value), SUB (subsidiary output) and outputs using analog signal. Output 2 specifications of transmission signal output depending on the format are also available.

For example it is used in applications like, selecting a PV transmission and connecting that analog signal to the recorder and recording the PV of this controller in the recorder. Specifications of analog signal are specified in a format.

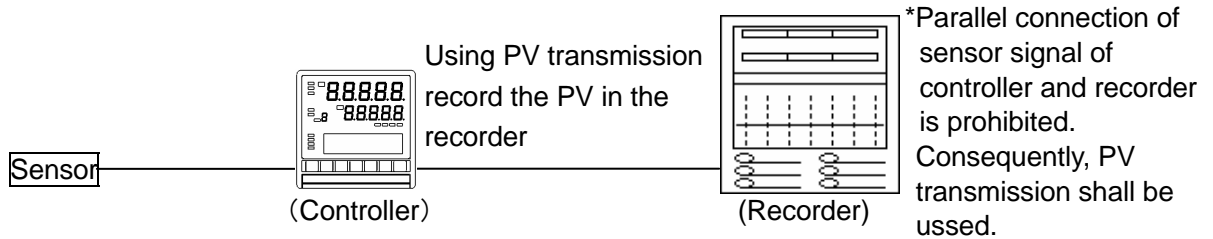

The following occurs when transmission signal output with 4-20mA specified and measurement range K1 and in a range of 0-1200°C transmits PV.

- Set 'PV' in transmission type of mode and '0-1200' in 'transmission scale'.

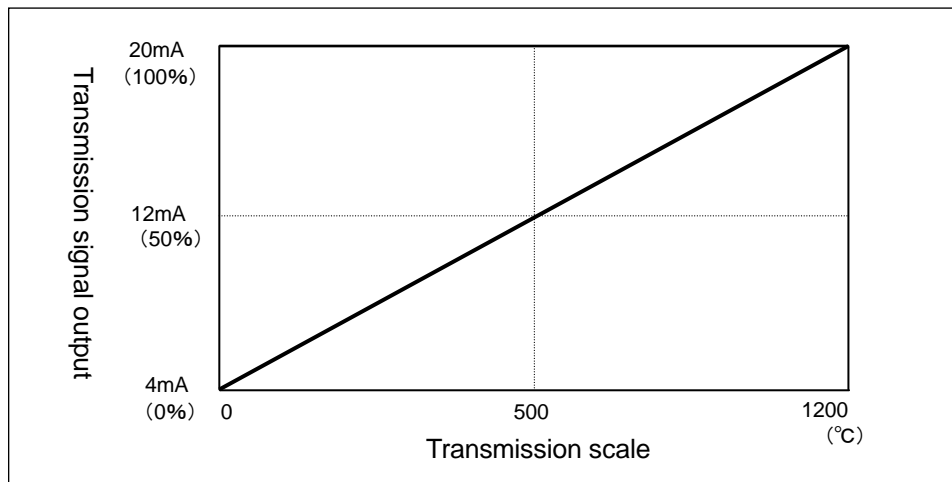



10-10. External signal input

In case of specifications with external drive input, this controller can have specific functions by using communication signal(ON/OFF) of external no contact signal (relay, switch, open-collector signal etc.).In 'External signal layout' of mode 11, terminal and function of external signal input is allotted and used. When external signal is allotted at 'External signal allotment' and external signal input is switched, key operation or switching by communications may be invalidated.

| Function name | Description |
|---------------|--|
| 1. RUN/STOP | <ul style="list-style-type: none"> ▪ RUN/STOP operation is done by external drive input. ▪ It is function of switching between RUN and STOP of program operation. ▪ Fixed external signal input is controlled by continuous signal. The status is RUN status after approximately 0.5 seconds or more after conduction (ON) and it is OFF status after approximately 0.5 seconds or more after non-conduction (OFF). ▪ It is enabled only when 'MASTER EXT' or 'MASTER FREE' is selected in 'Program drive system' of mode 1. ▪ Execution condition and operation contents etc are same as section 9-2 'Program operation and operation'. |
| 2. ADV | <ul style="list-style-type: none"> ▪ ADV operation is done by external drive input. ▪ It is a function to ADV (Advance: Progress) the step of program pattern. ▪ Fixed external signal input is controlled by momentary signal. Conduction (ON) is done for approximately 0.5 seconds or more and when it becomes non conducting (OFF) it advances (ADV) only by 1 step ▪ It is enabled only when 'MASTER EXT' or 'MASTER FREE' is selected in 'Program drive system' of mode 1. ▪ Execution condition and operation contents etc are same as section 9-2 'Program operation and operation'. |
| 3. RESET | <ul style="list-style-type: none"> ▪ RESET operation is done by external drive input. ▪ It is a function for resetting the program operation. ▪ Fixed external signal input is controlled by momentary signal. RESET status is obtained after around 1.0 seconds or more after conduction (ON). In order to return to normal status after RESET, choose non conduction (OFF) directly. ▪ It is enabled only when 'MASTER EXT' or 'MASTER FREE' is selected in 'Program drive system' of mode 1. ▪ Execution condition and operation contents etc are same as section 9-2 'Program operation and operation'. |
| 4. WAIT | <ul style="list-style-type: none"> ▪ Operation function exclusively for external drive input. ▪ It is a WAIT function for program operation. WAIT means stopping the program operation temporarily. In case of WAIT status, program operation is stopped by SV and time that exists just before WAIT and control operation is inherited by that SV. It is a function that is mainly used at the time of slave synchronous operation. ▪ Fixed external signal input is controlled by continuous signal. The status is WAIT status after approximately 0.5 seconds or more after conduction (ON). ▪ It is enabled only when 'MASTER EXT' or 'MASTER FREE' is selected in 'Program drive system' of mode 1. |

| Function name | Description | | | | | | | | | | | | | | | | | | | | | | | | | | | | | | | | | | | | | | | | | | | | | | | | | | | | | | | | | | | | | | | | | | | | | | | | | | | | | | | | | | | | | | | | | | | | | | | | | | | | | | | | | | | | | | | | | | | | | | | | | | | | | | | | | | | | | | | | | | | | |
|---|---|--------------|--------------|--------------|--------------|--------------|--------------|--------------|--------------|-------------|-------------|-------|---|---|---|---|---|---|---|---|---|-------|---|---|---|---|---|---|---|---|---|-------|---|---|---|---|---|---|---|---|---|-------|---|---|---|---|---|---|---|---|---|-------|---|---|---|---|---|---|---|---|---|-------|---|---|---|---|---|---|---|---|---|--|--------------|--------------|--------------|--------------|--------------|--------------|--------------|--------------|--------------|-------|---|---|---|---|---|---|---|---|---|-------|---|---|---|---|---|---|---|---|---|-------|---|---|---|---|---|---|---|---|---|-------|---|---|---|---|---|---|---|---|---|-------|---|---|---|---|---|---|---|---|---|-------|---|---|---|---|---|---|---|---|---|
| 5. FAST | <ul style="list-style-type: none"> • Run operation of FAST function is done using external drive signal. • It is a function for fast forwarding the program operation. • Fixed external signal input is controlled using continuous signal. The status becomes FAST after approximately 0.5 seconds or more after switching it ON (ON). • It is enabled only when 'MASTER EXT' or 'MASTER FREE' is selected in 'Program drive system' of mode 1. • Execution conditions and operation contents etc. are similar to 'Program operation and run operation' in section 9.2. | | | | | | | | | | | | | | | | | | | | | | | | | | | | | | | | | | | | | | | | | | | | | | | | | | | | | | | | | | | | | | | | | | | | | | | | | | | | | | | | | | | | | | | | | | | | | | | | | | | | | | | | | | | | | | | | | | | | | | | | | | | | | | | | | | | | | | | | | | | | |
| 6. PTN 1 PTN 2 PTN 4 PTN 8 PTN10 PTN20 | <ul style="list-style-type: none"> • Pattern number (PTN) is selected by external signal input. • Pattern number selection is based on control signal due to BCD code. • Fixed external signal input is controlled by continuous signal. See the example table below, depending on the pattern number to be selected, conduct (ON) external signal input with ○ mark. Pattern number is selected in around 0.5 seconds after conduction (ON). In addition, it is possible to select conducting patterns except ○ mark depend on the pattern number. For example, when select pattern No. 10, select conducting PTN8 and PTN2. <table border="1" data-bbox="507 913 1481 1594"> <thead> <tr> <th data-bbox="507 913 624 999"></th> <th data-bbox="624 913 703 999">PTN No.9</th> <th data-bbox="703 913 783 999">PTN No.8</th> <th data-bbox="783 913 863 999">PTN No.7</th> <th data-bbox="863 913 943 999">PTN No.6</th> <th data-bbox="943 913 1023 999">PTN No.5</th> <th data-bbox="1023 913 1102 999">PTN No.4</th> <th data-bbox="1102 913 1182 999">PTN No.3</th> <th data-bbox="1182 913 1262 999">PTN No.2</th> <th data-bbox="1262 913 1481 999">PTN No.1</th> </tr> </thead> <tbody> <tr> <td data-bbox="507 999 624 1043">PTN20</td> <td data-bbox="624 999 703 1043">×</td> <td data-bbox="703 999 783 1043">×</td> <td data-bbox="783 999 863 1043">×</td> <td data-bbox="863 999 943 1043">×</td> <td data-bbox="943 999 1023 1043">×</td> <td data-bbox="1023 999 1102 1043">×</td> <td data-bbox="1102 999 1182 1043">×</td> <td data-bbox="1182 999 1262 1043">×</td> <td data-bbox="1262 999 1481 1043">×</td> </tr> <tr> <td data-bbox="507 1043 624 1088">PTN10</td> <td data-bbox="624 1043 703 1088">×</td> <td data-bbox="703 1043 783 1088">×</td> <td data-bbox="783 1043 863 1088">×</td> <td data-bbox="863 1043 943 1088">×</td> <td data-bbox="943 1043 1023 1088">×</td> <td data-bbox="1023 1043 1102 1088">×</td> <td data-bbox="1102 1043 1182 1088">×</td> <td data-bbox="1182 1043 1262 1088">×</td> <td data-bbox="1262 1043 1481 1088">×</td> </tr> <tr> <td data-bbox="507 1088 624 1133">PTN 8</td> <td data-bbox="624 1088 703 1133">○</td> <td data-bbox="703 1088 783 1133">○</td> <td data-bbox="783 1088 863 1133">×</td> <td data-bbox="863 1088 943 1133">×</td> <td data-bbox="943 1088 1023 1133">×</td> <td data-bbox="1023 1088 1102 1133">×</td> <td data-bbox="1102 1088 1182 1133">×</td> <td data-bbox="1182 1088 1262 1133">×</td> <td data-bbox="1262 1088 1481 1133">×</td> </tr> <tr> <td data-bbox="507 1133 624 1178">PTN 4</td> <td data-bbox="624 1133 703 1178">×</td> <td data-bbox="703 1133 783 1178">×</td> <td data-bbox="783 1133 863 1178">○</td> <td data-bbox="863 1133 943 1178">○</td> <td data-bbox="943 1133 1023 1178">○</td> <td data-bbox="1023 1133 1102 1178">○</td> <td data-bbox="1102 1133 1182 1178">×</td> <td data-bbox="1182 1133 1262 1178">×</td> <td data-bbox="1262 1133 1481 1178">×</td> </tr> <tr> <td data-bbox="507 1178 624 1223">PTN 2</td> <td data-bbox="624 1178 703 1223">×</td> <td data-bbox="703 1178 783 1223">×</td> <td data-bbox="783 1178 863 1223">○</td> <td data-bbox="863 1178 943 1223">○</td> <td data-bbox="943 1178 1023 1223">×</td> <td data-bbox="1023 1178 1102 1223">×</td> <td data-bbox="1102 1178 1182 1223">○</td> <td data-bbox="1182 1178 1262 1223">○</td> <td data-bbox="1262 1178 1481 1223">×</td> </tr> <tr> <td data-bbox="507 1223 624 1267">PTN 1</td> <td data-bbox="624 1223 703 1267">○</td> <td data-bbox="703 1223 783 1267">×</td> <td data-bbox="783 1223 863 1267">○</td> <td data-bbox="863 1223 943 1267">×</td> <td data-bbox="943 1223 1023 1267">○</td> <td data-bbox="1023 1223 1102 1267">×</td> <td data-bbox="1102 1223 1182 1267">○</td> <td data-bbox="1182 1223 1262 1267">×</td> <td data-bbox="1262 1223 1481 1267">○</td> </tr> <tr> <th data-bbox="507 1267 624 1352"></th> <th data-bbox="624 1267 703 1352">PTN No.30</th> <th data-bbox="703 1267 783 1352">PTN No.29</th> <th data-bbox="783 1267 863 1352">PTN No.26</th> <th data-bbox="863 1267 943 1352">PTN No.22</th> <th data-bbox="943 1267 1023 1352">PTN No.20</th> <th data-bbox="1023 1267 1102 1352">PTN No.17</th> <th data-bbox="1102 1267 1182 1352">PTN No.15</th> <th data-bbox="1182 1267 1262 1352">PTN No.13</th> <th data-bbox="1262 1267 1481 1352">PTN No.10</th> </tr> <tr> <td data-bbox="507 1352 624 1397">PTN20</td> <td data-bbox="624 1352 703 1397">○</td> <td data-bbox="703 1352 783 1397">○</td> <td data-bbox="783 1352 863 1397">○</td> <td data-bbox="863 1352 943 1397">○</td> <td data-bbox="943 1352 1023 1397">○</td> <td data-bbox="1023 1352 1102 1397">×</td> <td data-bbox="1102 1352 1182 1397">×</td> <td data-bbox="1182 1352 1262 1397">×</td> <td data-bbox="1262 1352 1481 1397">×</td> </tr> <tr> <td data-bbox="507 1397 624 1442">PTN10</td> <td data-bbox="624 1397 703 1442">○</td> <td data-bbox="703 1397 783 1442">×</td> <td data-bbox="783 1397 863 1442">×</td> <td data-bbox="863 1397 943 1442">×</td> <td data-bbox="943 1397 1023 1442">×</td> <td data-bbox="1023 1397 1102 1442">○</td> <td data-bbox="1102 1397 1182 1442">○</td> <td data-bbox="1182 1397 1262 1442">○</td> <td data-bbox="1262 1397 1481 1442">○</td> </tr> <tr> <td data-bbox="507 1442 624 1487">PTN 8</td> <td data-bbox="624 1442 703 1487">×</td> <td data-bbox="703 1442 783 1487">○</td> <td data-bbox="783 1442 863 1487">×</td> <td data-bbox="863 1442 943 1487">×</td> <td data-bbox="943 1442 1023 1487">×</td> <td data-bbox="1023 1442 1102 1487">×</td> <td data-bbox="1102 1442 1182 1487">×</td> <td data-bbox="1182 1442 1262 1487">×</td> <td data-bbox="1262 1442 1481 1487">×</td> </tr> <tr> <td data-bbox="507 1487 624 1532">PTN 4</td> <td data-bbox="624 1487 703 1532">×</td> <td data-bbox="703 1487 783 1532">×</td> <td data-bbox="783 1487 863 1532">○</td> <td data-bbox="863 1487 943 1532">×</td> <td data-bbox="943 1487 1023 1532">×</td> <td data-bbox="1023 1487 1102 1532">○</td> <td data-bbox="1102 1487 1182 1532">○</td> <td data-bbox="1182 1487 1262 1532">×</td> <td data-bbox="1262 1487 1481 1532">×</td> </tr> <tr> <td data-bbox="507 1532 624 1576">PTN 2</td> <td data-bbox="624 1532 703 1576">×</td> <td data-bbox="703 1532 783 1576">×</td> <td data-bbox="783 1532 863 1576">○</td> <td data-bbox="863 1532 943 1576">○</td> <td data-bbox="943 1532 1023 1576">×</td> <td data-bbox="1023 1532 1102 1576">○</td> <td data-bbox="1102 1532 1182 1576">×</td> <td data-bbox="1182 1532 1262 1576">○</td> <td data-bbox="1262 1532 1481 1576">×</td> </tr> <tr> <td data-bbox="507 1576 624 1594">PTN 1</td> <td data-bbox="624 1576 703 1594">×</td> <td data-bbox="703 1576 783 1594">○</td> <td data-bbox="783 1576 863 1594">×</td> <td data-bbox="863 1576 943 1594">×</td> <td data-bbox="943 1576 1023 1594">×</td> <td data-bbox="1023 1576 1102 1594">○</td> <td data-bbox="1102 1576 1182 1594">○</td> <td data-bbox="1182 1576 1262 1594">○</td> <td data-bbox="1262 1576 1481 1594">×</td> </tr> </tbody> </table> <ul style="list-style-type: none"> • When BCD code with pattern number other than 0-30 is selected, the pattern number that is selected earlier remains. • It is enabled only when 'EXT' or 'FREE' is selected in 'Pattern selection system' of mode 1. • As an example if only pattern numbers 1-4 need to be selected, only three external signal inputs of PTN 1, PTN 2, PTN 3, PTN 4 can be assigned. • Execution condition and operation contents etc are same as section 9-2 'Program operation and operation'. | | PTN No.9 | PTN No.8 | PTN No.7 | PTN No.6 | PTN No.5 | PTN No.4 | PTN No.3 | PTN No.2 | PTN No.1 | PTN20 | × | × | × | × | × | × | × | × | × | PTN10 | × | × | × | × | × | × | × | × | × | PTN 8 | ○ | ○ | × | × | × | × | × | × | × | PTN 4 | × | × | ○ | ○ | ○ | ○ | × | × | × | PTN 2 | × | × | ○ | ○ | × | × | ○ | ○ | × | PTN 1 | ○ | × | ○ | × | ○ | × | ○ | × | ○ | | PTN No.30 | PTN No.29 | PTN No.26 | PTN No.22 | PTN No.20 | PTN No.17 | PTN No.15 | PTN No.13 | PTN No.10 | PTN20 | ○ | ○ | ○ | ○ | ○ | × | × | × | × | PTN10 | ○ | × | × | × | × | ○ | ○ | ○ | ○ | PTN 8 | × | ○ | × | × | × | × | × | × | × | PTN 4 | × | × | ○ | × | × | ○ | ○ | × | × | PTN 2 | × | × | ○ | ○ | × | ○ | × | ○ | × | PTN 1 | × | ○ | × | × | × | ○ | ○ | ○ | × |
| | PTN No.9 | PTN No.8 | PTN No.7 | PTN No.6 | PTN No.5 | PTN No.4 | PTN No.3 | PTN No.2 | PTN No.1 | | | | | | | | | | | | | | | | | | | | | | | | | | | | | | | | | | | | | | | | | | | | | | | | | | | | | | | | | | | | | | | | | | | | | | | | | | | | | | | | | | | | | | | | | | | | | | | | | | | | | | | | | | | | | | | | | | | | | | | | | | | | | | | | | | | | |
| PTN20 | × | × | × | × | × | × | × | × | × | | | | | | | | | | | | | | | | | | | | | | | | | | | | | | | | | | | | | | | | | | | | | | | | | | | | | | | | | | | | | | | | | | | | | | | | | | | | | | | | | | | | | | | | | | | | | | | | | | | | | | | | | | | | | | | | | | | | | | | | | | | | | | | | | | | | |
| PTN10 | × | × | × | × | × | × | × | × | × | | | | | | | | | | | | | | | | | | | | | | | | | | | | | | | | | | | | | | | | | | | | | | | | | | | | | | | | | | | | | | | | | | | | | | | | | | | | | | | | | | | | | | | | | | | | | | | | | | | | | | | | | | | | | | | | | | | | | | | | | | | | | | | | | | | | |
| PTN 8 | ○ | ○ | × | × | × | × | × | × | × | | | | | | | | | | | | | | | | | | | | | | | | | | | | | | | | | | | | | | | | | | | | | | | | | | | | | | | | | | | | | | | | | | | | | | | | | | | | | | | | | | | | | | | | | | | | | | | | | | | | | | | | | | | | | | | | | | | | | | | | | | | | | | | | | | | | |
| PTN 4 | × | × | ○ | ○ | ○ | ○ | × | × | × | | | | | | | | | | | | | | | | | | | | | | | | | | | | | | | | | | | | | | | | | | | | | | | | | | | | | | | | | | | | | | | | | | | | | | | | | | | | | | | | | | | | | | | | | | | | | | | | | | | | | | | | | | | | | | | | | | | | | | | | | | | | | | | | | | | | |
| PTN 2 | × | × | ○ | ○ | × | × | ○ | ○ | × | | | | | | | | | | | | | | | | | | | | | | | | | | | | | | | | | | | | | | | | | | | | | | | | | | | | | | | | | | | | | | | | | | | | | | | | | | | | | | | | | | | | | | | | | | | | | | | | | | | | | | | | | | | | | | | | | | | | | | | | | | | | | | | | | | | | |
| PTN 1 | ○ | × | ○ | × | ○ | × | ○ | × | ○ | | | | | | | | | | | | | | | | | | | | | | | | | | | | | | | | | | | | | | | | | | | | | | | | | | | | | | | | | | | | | | | | | | | | | | | | | | | | | | | | | | | | | | | | | | | | | | | | | | | | | | | | | | | | | | | | | | | | | | | | | | | | | | | | | | | | |
| | PTN No.30 | PTN No.29 | PTN No.26 | PTN No.22 | PTN No.20 | PTN No.17 | PTN No.15 | PTN No.13 | PTN No.10 | | | | | | | | | | | | | | | | | | | | | | | | | | | | | | | | | | | | | | | | | | | | | | | | | | | | | | | | | | | | | | | | | | | | | | | | | | | | | | | | | | | | | | | | | | | | | | | | | | | | | | | | | | | | | | | | | | | | | | | | | | | | | | | | | | | | |
| PTN20 | ○ | ○ | ○ | ○ | ○ | × | × | × | × | | | | | | | | | | | | | | | | | | | | | | | | | | | | | | | | | | | | | | | | | | | | | | | | | | | | | | | | | | | | | | | | | | | | | | | | | | | | | | | | | | | | | | | | | | | | | | | | | | | | | | | | | | | | | | | | | | | | | | | | | | | | | | | | | | | | |
| PTN10 | ○ | × | × | × | × | ○ | ○ | ○ | ○ | | | | | | | | | | | | | | | | | | | | | | | | | | | | | | | | | | | | | | | | | | | | | | | | | | | | | | | | | | | | | | | | | | | | | | | | | | | | | | | | | | | | | | | | | | | | | | | | | | | | | | | | | | | | | | | | | | | | | | | | | | | | | | | | | | | | |
| PTN 8 | × | ○ | × | × | × | × | × | × | × | | | | | | | | | | | | | | | | | | | | | | | | | | | | | | | | | | | | | | | | | | | | | | | | | | | | | | | | | | | | | | | | | | | | | | | | | | | | | | | | | | | | | | | | | | | | | | | | | | | | | | | | | | | | | | | | | | | | | | | | | | | | | | | | | | | | |
| PTN 4 | × | × | ○ | × | × | ○ | ○ | × | × | | | | | | | | | | | | | | | | | | | | | | | | | | | | | | | | | | | | | | | | | | | | | | | | | | | | | | | | | | | | | | | | | | | | | | | | | | | | | | | | | | | | | | | | | | | | | | | | | | | | | | | | | | | | | | | | | | | | | | | | | | | | | | | | | | | | |
| PTN 2 | × | × | ○ | ○ | × | ○ | × | ○ | × | | | | | | | | | | | | | | | | | | | | | | | | | | | | | | | | | | | | | | | | | | | | | | | | | | | | | | | | | | | | | | | | | | | | | | | | | | | | | | | | | | | | | | | | | | | | | | | | | | | | | | | | | | | | | | | | | | | | | | | | | | | | | | | | | | | | |
| PTN 1 | × | ○ | × | × | × | ○ | ○ | ○ | × | | | | | | | | | | | | | | | | | | | | | | | | | | | | | | | | | | | | | | | | | | | | | | | | | | | | | | | | | | | | | | | | | | | | | | | | | | | | | | | | | | | | | | | | | | | | | | | | | | | | | | | | | | | | | | | | | | | | | | | | | | | | | | | | | | | | |

| Function name | Description |
|----------------|---|
| 7. MAN1/AUTO1 | <ul style="list-style-type: none"> · It is a function for switching between manual output operation (manual output) and automatic output operation (automatic output) of output 1. · Fixed external signal input is controlled by continuous signal. In around 0.5 seconds or more after conduction (ON), it is manual output operation and in around 0.5 seconds or more after non-conduction (OFF), it is automatic output operation. · When switching between MAN/AUTO is done using external signal input, the key operation on the operation screen selects 'AUTO' and then switching is done by external signal input. · At the time of manual output switching, 'e' is displayed on the left side of 'OUT' on the operation screen.  |
| 8. MAN2/AUTO2 | <ul style="list-style-type: none"> · It is a function for switching between manual output operation (Manual output) and automatic output operation (automatic output) of output 2 and only output 2 specifications can be selected. · Fixed external signal input is controlled by continuous signal. In around 0.5 seconds or more after conduction (ON), it is manual output operation and in around 0.5 seconds or more after non-conduction (OFF), it is automatic output operation. · When switching between MAN/AUTO is done using external signal input, the key operation on the operation screen selects 'AUTO' and then switching is done by external signal input. · At the time of manual output switching, 'e' is displayed on the left side of 'OUT' on the operation screen.  |
| 9. PRESET/AUTO | <ul style="list-style-type: none"> · It is a function for switching between output preset operation (Preset manual output) and automatic output operation (Auto output). · Fixed external signal input is controlled by continuous signal. In around 0.5 seconds or more after conduction (ON), it is output preset operation and in around 0.5 seconds or more after non-conduction (OFF), it is automatic output operation. · MV (Output value) becomes the setting value according to the variation ration set in No. 9 of variation limiter when one switches from automatic output operation to output preset operation. When switching from output preset operation to automatic output operation, it becomes automatic output operation according to bump less balance less operation. · In case of output preset operation, output value becomes the setting value of 'preset manual' of mode 4, alarm operation is executed and auto tuning cannot be executed. · 'p' is displayed on the left side of 'OUT' of the operation screen at the time of switching the preset manual output.  |

| Function name | Description |
|--|---|
| 10. ALARM RESET | <ul style="list-style-type: none"> · It is a function that resets (cancels) alarm output. · Fixed external signal input is controlled by momentary signal. In around 0.5 seconds or more after conduction (ON), it is reset. After reset as it returns to normal status, immediately change to non conduction (OFF). |
| 11. PV HOLD | <ul style="list-style-type: none"> · It is the PV hold function. · Fixed external signal input is controlled by continuous signal. In around 0.5 seconds or more after conduction (ON), status is 'hold'. · When performing 'hold' using external signal 'PV hold' of mode 1 selects 'NON' and switching is done by external signal input. · Hold status is the value of PV just before the settings and PV is fixed and control action continues with that PV. |
| 12. TIMER1 TIMER2 TIMER3 TIMER4 | <ul style="list-style-type: none"> · It is a function for switching between timer start/reset. · Fixed external signal input is controlled by continuous signal. In around 0.5 seconds or more after conduction (ON), the status of timer is start and in around 0.5 seconds or more after non-conduction (OFF), it is reset. · TIMER1, TIMER2, TIMER3 and TIMER4 are respectively allotted to AL1, AL2, AL3 and AL4. |

*1 No setting condition '----' is displayed when shipped from factory. If set any function once, not setting condition is not displayed. Allocation setting is not initialized (no setting condition), even if contents of settings are initialized.

10-11. External signal output

In case of specifications with external drive input, this controller can output externally the time signal and various status signals by using open-collector signal. In 'External signal layout' of mode 11, terminal and function of external signal output is allotted and used.

| Function name | Description |
|---|---|
| 1. TS1 TS2 TS3 TS4 TS5 TS6 TS7 TS8 | <ul style="list-style-type: none"> It is a time signal (continuous signal). There are 8 types of time signals from TS 1 to TS 8. When time signal is ON output signal is ON. |
| 2. RUN/STOP | <ul style="list-style-type: none"> It is the status signal of RUN/STOP (continuous signal). When operation status is RUN output signal is ON and when it is STOP output signal is OFF. |
| 3. ADV | <ul style="list-style-type: none"> It is the status signal of ADV (momentary signal). When operation status signal is ADV (Advance: Progress) output signal is ON only for around 0.5 seconds. |
| 4. RESET | <ul style="list-style-type: none"> It is the status signal of RESET (Continuous signal). When operation status is RESET, output signal is ON. |
| 5. WAIT | <ul style="list-style-type: none"> It is the status signal of WAIT (Continuous signal). When operation status is WAIT, output signal is ON. WAIT means waiting during real temperature compensation and in external signal input the status is WAIT at the time of ON. |
| 6. END | <ul style="list-style-type: none"> It is the status signal of END (Continuous). When operation status is END (program end) output signal is ON. |

*' No setting condition '-----' is displayed when shipped from factory. If set any function once, not setting condition is not displayed. Allocation setting is not initialized (no setting condition), even if contents of settings are initialized.

Operation status and status signal are shown together in the diagram as follows.

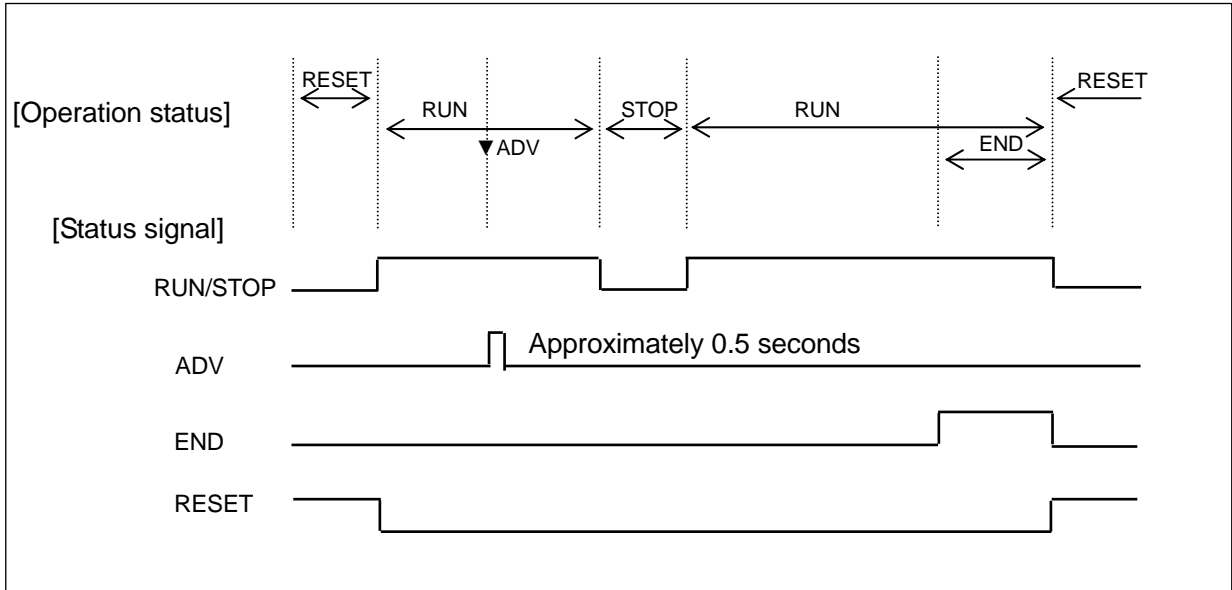

10-12. Timer slave synchronous operation

In case of specifications with external signal input and external signal output only, by combining external drive signal and status signal for a number of KP series unit and also including real temperature compensation status synchronous program operation can be done.

Even when real time compensation operation takes place, a system that inherits synchronous operation is called master slave synchronous operation and it is one of the excellent functions of KP series. In case of real time compensation operation, when asynchronous operation is okay, it is okay to operate using series connection of general external drive signal.

1. View point

Combine external drive signal and status signal. From among a number of units performing synchronous operation, consider one unit as master instrument and the rest of them as slave instruments. Slave instruments will receive from the master instrument the status signal by using external drive signal and will run the program. If any one of the units is in WAIT status during real temperature compensation operation, by sending the status signal of that WAIT to WAIT of external drive signal of the master instrument, all the other slave instruments also get the WAIT status. Thus in case of real temperature compensation operation also, a synchronous operation that minimizes temporal errors can be realized.

2. Wiring

An example of basic master slave synchronous operation wiring is given below.

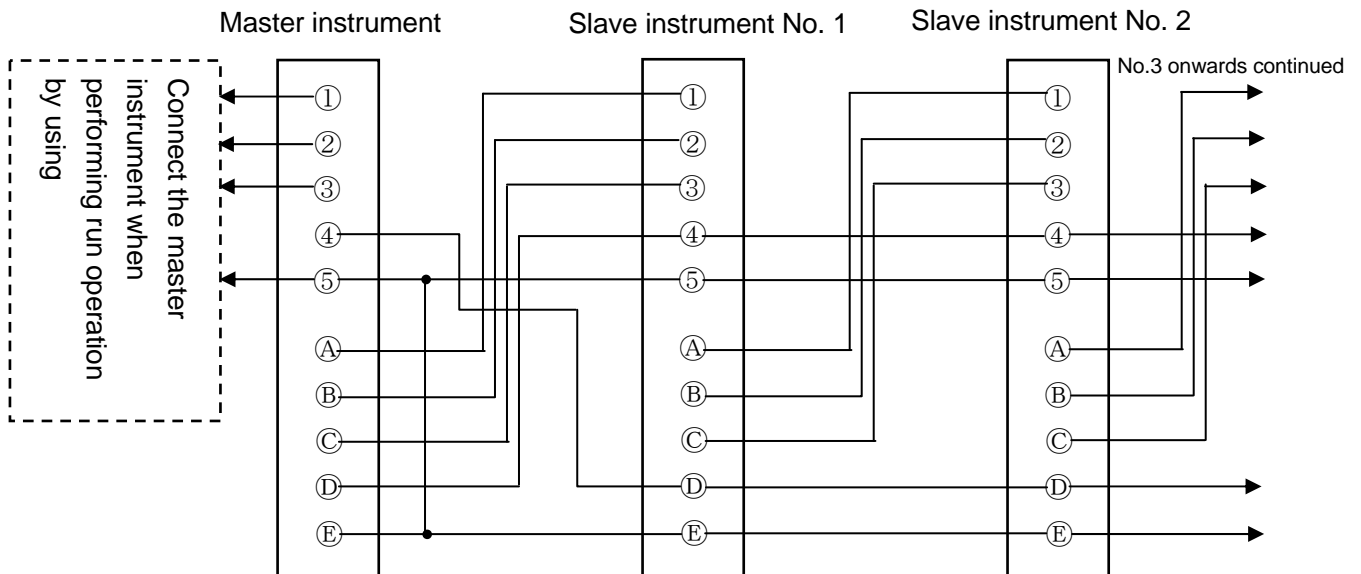

| Master drive input | | Status signal | |
|--------------------|----------|---------------|----------|
| Terminal | Function | Terminal | Function |
| ① | RUN/STOP | Ⓐ | RUN/STOP |
| ② | ADV | Ⓑ | ADV |
| ③ | RESET | Ⓒ | RESET |
| ④ | WAIT | Ⓓ | WAIT |
| ⑤ | COM | Ⓔ | COM |

※ As terminal is a tentative number, replace it by the terminal number you are using and read.

3. Setting

Set the 'Program drive operation' of mode 1 as follows.

| | Setting contents |
|-------------------|---|
| Master instrument | Set from any of the following. <ul style="list-style-type: none">▪ 'MASTER KEY' : Set when performing the run operation using the front key.▪ 'MASTER EXT' : Set when performing run operation by using external drive input.▪ 'MASTER COM' : Set when performing run operation by communication. However it can be selected only in case of specifications with communication.▪ 'MASTER FREE' : Set when performing the run operation by front key/external drive signal/communication optional signal. However, communication can be selected only in case of specifications with communication. |
| Slave instrument | Set all to 'SLAVE EXT'. |

When 'MASTER FREE' is set in master instrument, run operation can be done by optional signal instead of changing the settings and it is convenient, however, as run status is based on the signal that is last sent, it is very difficult to judge as to on which signal does the last operation signal depend.

For example, when operating using both, front key and external drive signal, the status of external switch connected to external drive input and actual operation status may differ. Thus this is normal for this controller however for the entire system of the final product it may be received as mal operation which is risky hence take care.

In order to avoid the mal operation of the entire we do not recommend 'MASTER FREE' setting.

4. Operation

① Run operation

- Run operation is executed for master device only.
- All the slave devices are run by synchronizing them with the status signal of the master device.

② Real temperature compensation operation

- When real temperature compensation is done on any one machine, WAIT status signal is output from that machine and WAIT signal is sent to all the slave devices from this master device. Thus all the connected products have the wait status and are synchronized.

10-13. Communication interface

The controller is provided with various communication functions and they are as follows.

10-13-1. Engineering port

It is a communication function provided in all the products. Engineering port exists on the right side on the front after opening the lower cover of the front part. Communication with the PC can be done by connecting an exclusive engineering cable (sold separately).

Specifications of communication by using the engineering port is as follows.

- Communication protocol: MODBUS-RTU
- Communication speed: 9600bps
- Communication character: bit length 8/parity NON/stop bit 1

10-13-2. Specifications with communication

Usually when doing communications, select specifications with communication. Type of communication can be selected from amongst RS232C, RS422A and RS485.

Communication enables the setting of parameters (Data Write) and data reading (Data Read) by connecting to PC and remote operation for which PC is used and data management can be done. As one more function of KP series, is the communication transmission (digital transmission) function. It is a function which is combined with digital indicating controller DB series which is a sister model, and SV transmission is sent from KP series using communication and by receiving it as remote SV of DB series, using communication, a remote operation without any error at all can be realized. Remote operation due to remote signal input of DB series is called Analog Remote, and remote operation due to communication remote is called Digital Remote.

The following diagram is a model example of remote operation by communication transmission through KP series and communication remote function due to DB series, while selecting specifications with 2 port communication and performing high order communication with the PC.

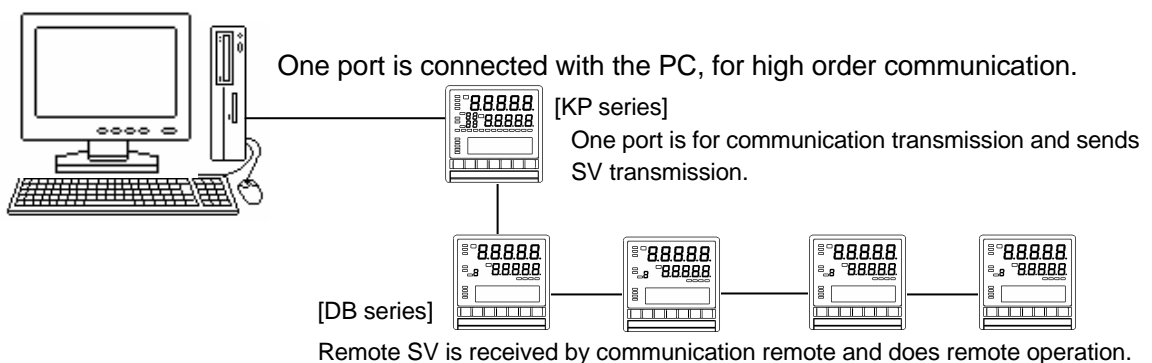

10-14. Customer scale correction

In this controller a function for correcting the customer scale is provided in mode 12. High precision voltage current occurrence device, digital multi-meter, dial resistance device etc. is prepared and customer scale correction can be done.

10-14-1. Overview

This function can perform scale correction of the following input output functions.

- Measurement range.
- Output 1 (Output 1 is only current output or voltage output).
- Output 2 (Output 2 is only current output or voltage output).
- Remote signal input (With remote signal input only).
- High precision type transmission signal output (With transmission signal output only).
- Normal type transmission signal output (With transmission signal output only).
- CT input (With heater snapping wire alarm only).

10-14-2. Viewpoint of scale correction

Scale correction is done by internal operation process using the following expression [$Y=aX+b$] and two correction values namely zero correction (equivalent to b) and span correction (equivalent to a) are used.

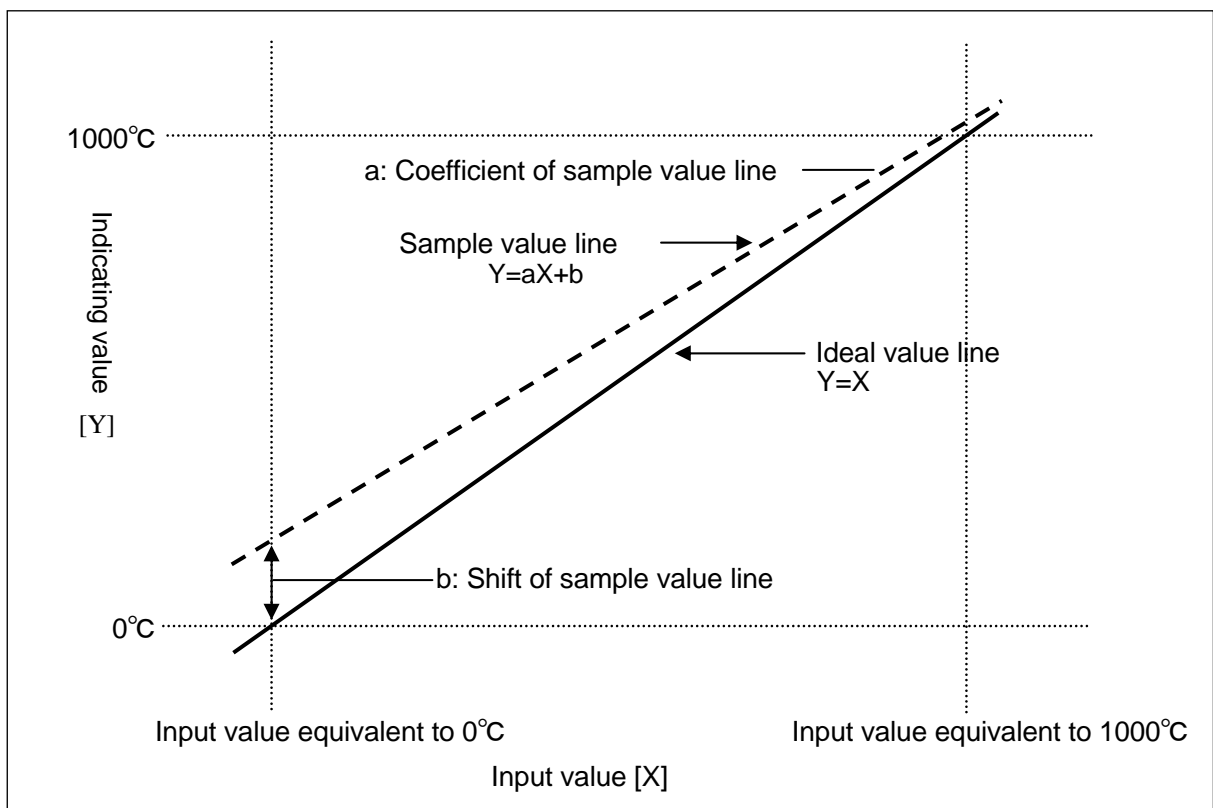

Ideal value line is a straight line when there is no measurement error. If 'input value equivalent to 0°C' is entered, 0°C is indicated whereas when 'input value equivalent to 1000°C' is entered, 1000°C is indicated.

Thus according to the expression as there is no correction value, $Y=X$.

In case of sample value line, as compared to ideal value line, it shifts to + side by b units in the neighborhood of 0°C and the tilt of straight line lowers.

For example when 'input value equivalent to 0°C' is entered '+20°C' is indicated and when 'input value equivalent to 1000°C' is entered, 1005°C is indicated and so on.

Thus bias(b) equivalent to -20°C is added and multiplication by a coefficient that increases the tilting is done and thus ideal straight line is obtained. In other words, indicator shift can be lost.

Thus the expression is $Y=aX-b$.

10-14-3. Input related scale correction

Details about the procedure for input related (measurement range, CT input) scale correction are as follows.

Scale correction of measurement range is done in the measurement range that is selected, hence if other measurement scale is scale is selected after correction, indicator shifting occurs. This is because even when any measurement range is selected, the scale correction function operates with the same scale correction value. After the scale correction if measurement range is changed, perform scale correction again.

1. Preparations related to measurement device

| Input to be corrected | Required measurement device and instruments |
|--|--|
| Measurement range | <p>① High precision voltage current occurrence device ※ Required for thermocouple, DC voltage, DC current correction.</p> <p>· Accuracy: Less than $\pm 0.05\%$.</p> <p>② Digital multi-meter ※ Required for thermocouple, DC voltage, DC current correction.</p> <p>· Accuracy: Less than $\pm 0.05\%$.</p> <p>· If the accuracy of the voltage current occurrence device of clause ① is not good, confirm the voltage value (current value) using digital multi-meter also.</p> <p>③ Dial resistance ※ Required in correction of resistance thermometer.</p> <p>· Accuracy: Less than $\pm 0.05\%$.</p> <p>④ Thermocouple ※ Required in correction of thermocouple.</p> <p>· JIS:0.4 level.</p> <p>⑤ Freezing point expression reference junction ※ Required in correction of thermocouple.</p> <p>· Accuracy: Less than $\pm 0.1^\circ\text{C}$.</p> <p>· Freezing point device that uses triple point of water.</p> |
| CT input (Heater snapping wire alarm) | <p>① AC current occurrence device</p> <p>· Accuracy: Less than $\pm 0.2\%$.</p> |



Warning

To avoid serious accidents always cut off the power supply and then do the wiring.

2. Wiring

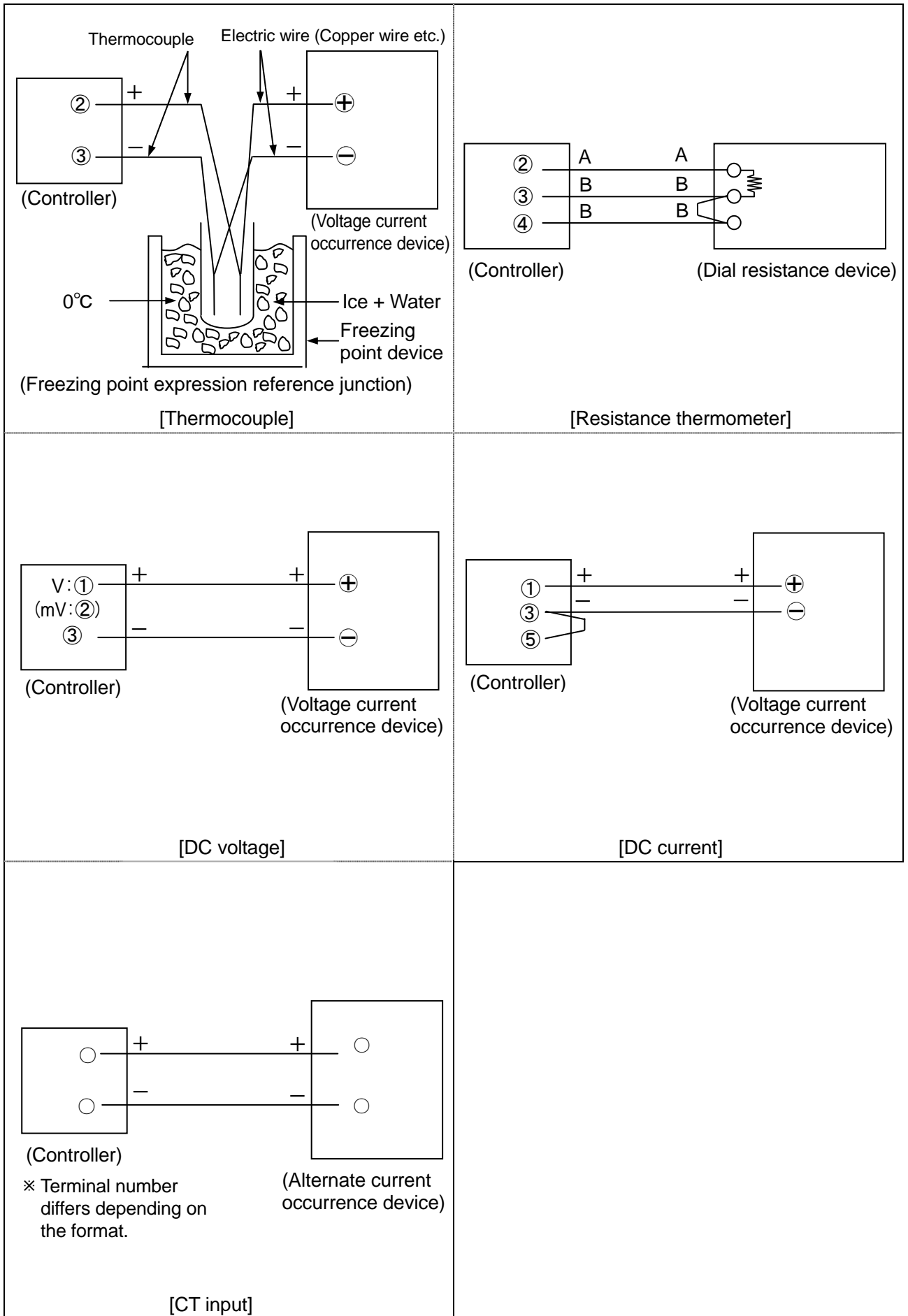

3. Scale correction

① Preparation and conduction

- By making operation condition of the controller as 'standard operation condition' the controller is stabilized.
- After confirming the wiring, it is stabilized by making relation of the controller and the measurement device stable.

② Indicator check before scale correction

- Select the measurement range that is to be actually used, refer to the following and perform indicator check (3 places) before scale correction.

In case of thermocouple refer to thermo-electromotive table and in case of resistance thermometer refer to resistance value table and confirm the input values.

| | Minimum value : □□□°C (Input value: □□□mV) | Medium value : □□□°C (Input value: □□□mV) | Maximum value : □□□°C (Input value: □□□mV) |
|-----------------------------------|---|--|---|
| Indicator check before correction | | | |
| Indicator check after correction | | | |

③ Setting the zero correction value

- Enter the minimum value of measurement range.
- Compare the minimum value with the ideal value, if it is positive, set a negative zero correction value and if it is negative, set a positive zero correction value.
- By referring to the PV (measurement value), set the zero correction value such that it matches the ideal value.

④ Setting the span correction value

- Enter the maximum value of measurement range.
- If maximum value is positive as compared to ideal value, set the span correction value less than 1.0 and if the value is negative, set the span correction value as 1.0 or more.
- By referring to the PV (measurement value), set the span correction value such that it matches the ideal value.

⑤ Readjustment

- Repeat the adjustment mentioned in clauses ③ and ④ a number of times till the indicator value is in the permitted range.

⑥ Indicator check after correction

- Perform this check in the same way as the indicator check (3 places) before correction and confirm that there is no problem.

⑦ Precautions during scale correction of CT input

- CT input can measure heater current up to 100A by connecting external CT. Secondary current that is transformed by external CT is several ten mA, and those several ten mA are entered in this controller and heater current is measured indirectly. Hence in the scale correction of CT input, input the following standard current that is fixed (decided).

| | Minimum value : 10A (Input value:12.4mA AC) | Medium value : 50A (Input value : 68.2mA AC) | Maximum value : 100A (Input value :124.0mA AC) |
|-----------------------------------|--|---|---|
| Indicator check before correction | | | |
| Indicator check after correction | | | |

- Unit of standard current is mA. See to it that excessive current is not applied.
- Setting procedure of correction value is same as ③, ④, ⑤. However in order to display the CT measurement value, set 'ON' in 'CT screen existence' of mode 1 and make the manual output operation as 100% and it is necessary to set the condition that enables the display of CT measurement value in the operation screen.

| | |
|--|--|
|  Precautions | <p>① If power supply that is out of rating range is connected, the product may get out of order, performance may deteriorate or it may malfunction.</p> <p>② If excess voltage or excess current is applied to input output terminal of the controller, the product may get out of order, performance may deteriorate or it may malfunction.</p> |
|--|--|

10-14-4. Output related scale correction

Detailed procedure of output related (Current output/voltage output, transmission signal output) scale correction is as follows.

1. Preparation of measurement devices

| Input to be corrected | Required measurement devices and tools |
|-------------------------------|---|
| Current output/voltage output | ① Digital multi-meter · Accuracy: Less than $\pm 0.05\%$. |
| Transmission signal output | ① Digital multi-meter · Accuracy: Less than $\pm 0.05\%$. |

2. Wiring

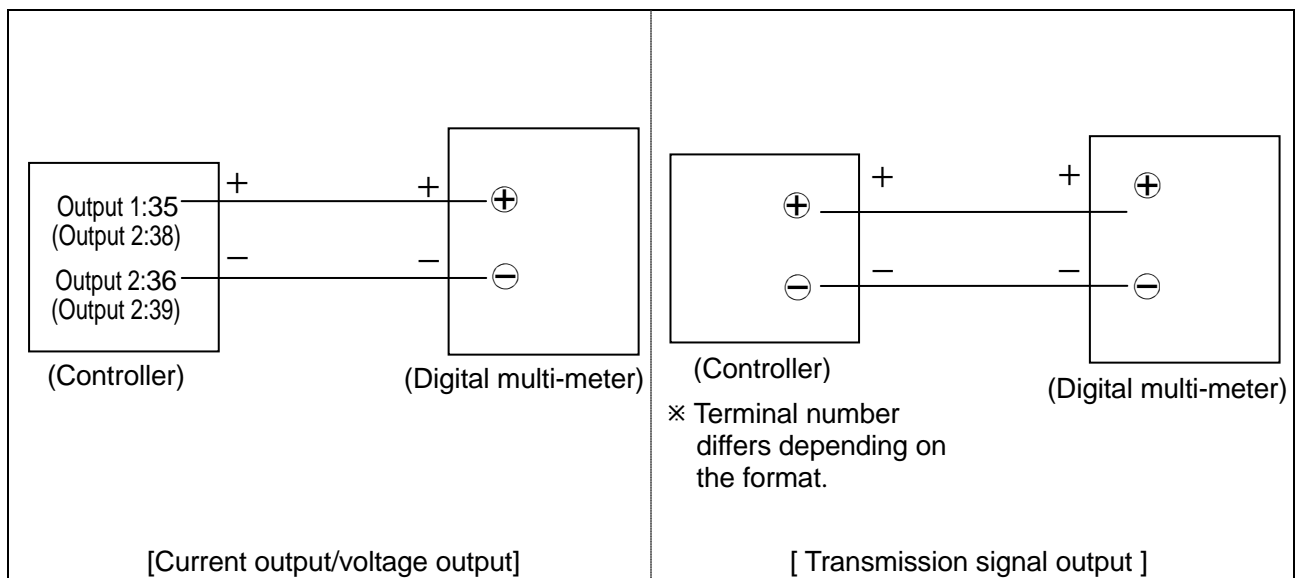

3. Scale correction

① Preparation and conduction

- By making operation environment of the controller as 'standard operation condition' the controller is stabilized.
- After confirming the wiring, it is stabilized by making relation of the controller and the measurement device stable.

② Indicator check before scale correction

- Refer to the following and perform the output check (3 places) before correction.

| | Minimum value : □□mA (Input value : 0%) | Medium value: □□mA (Output value: 50%) | Maximum value: □□mA (Output value: 100%) |
|-----------------------------------|--|---|---|
| Indicator check before correction | | | |
| Indicator check after correction | | | |

③ Setting zero correction value

- Output, output value 0%.
- If minimum value is positive as compared to ideal value, set negative value for zero correction and if maximum value is negative as compared to ideal value, set positive value for zero correction.
- By referring to the digital multi-meter, set the zero correction value such that it matches the ideal value.

- ④ Setting the span correction value
 - Output, output value 100%.
 - If maximum value is positive as compared to ideal value, set the span correction value less than 1.0 and if the value is negative, set the span correction value as 1.0 or more.
 - By referring to the digital multi-meter, set the span correction value such that it matches the ideal value.
- ⑤ Readjustment
 - Repeat the adjustment mentioned in clauses ③ and ④ a number of times till the indicator value is in the permitted range.
- ⑥ Indicator check after correction
 - Perform this check in the same way as the indicator check (3 places) before correction and confirm that there is no problem.
- ⑦ Precautions during scale correction of current output/voltage output
 - Current output and voltage output that exists in MV (output value) are adjusted such that they can be output in a range slightly broader than the factory shipping status. In other words for current output, at the time of 0% current is 4.0mA, adjusted to approximately 3.5 to 3.9mA and at the time of 100% current is 20.0mA adjusted to approximately 20.1 to 20.5mA. Normally in case of current output it is connected to the operation terminal like thyristor regulator, but in order to operate it as operation terminal in a certain range of 0-100%, eliminate the input error of those operation terminals. and make it such that it outputs in some broader range.
 - Accordingly, we recommend that you adjust current output and voltage output which is MV (output value) can be adjusted to some low value for 0% and some high value for 100%. However adjust the transmission output exactly to the standard value without considering such things.

11. Engineering port

This function can connect with the PC from the front of the controller. Even if this function is not in the specifications with communication interface, it is provided as standard to all products.

An exclusive engineering cable is inserted in this port and connected to the PC.

Parameter setup software 'PASS' is available with our company. Various parameters can be easily set from the front of the controller by using this 'PASS' and engineering cable, and PC.

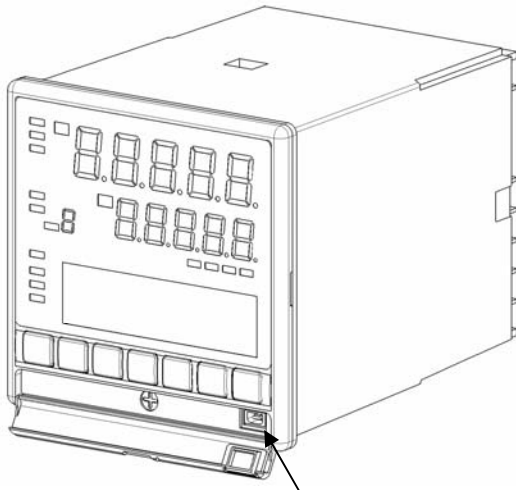

Engineering port

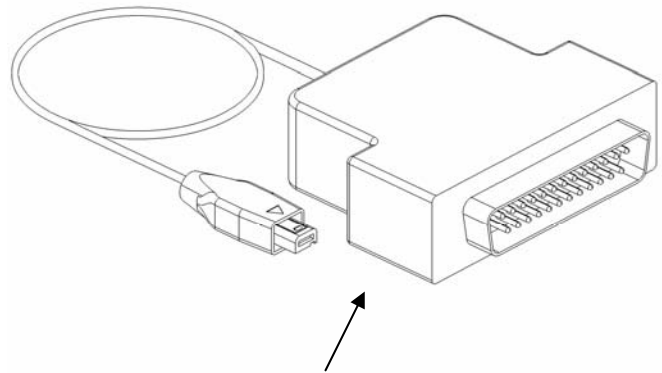

Engineering cable

Engineering port is used for temporary communication connection on that structure and is not for usual connection. If you want to carry out the communication by usual connection, while purchasing specify specifications with communication interface and do a permanent connection from the back side.



Precaution

Connecting and disconnecting of engineering cable to engineering port in this instrument should be done while applying power.

12. Trouble shooting

| Condition | Items to be confirmed |
|--|--|
| 1. There is an error in PV or PV is not stable | <ul style="list-style-type: none"> ▪ Confirm that there is no problem in the wiring with the sensor. ▪ For thermocouple, confirm that wiring is done till the terminal screw by using thermocouple and compensation lead wire. ▪ Confirm that the terminal screws are tightened properly. ▪ Confirm that sensor signal is not connected in parallel with other instrument. ▪ Confirm that protective elements etc are connected to sensor signal and the impedance does not become high. ▪ Confirm that there is no problem in output specifications (impedance etc.) and output signal of sensor itself. ▪ Confirm that ground terminal is connected to good quality protective ground. ▪ Confirm that there is no noise. ▪ Confirm that there is no problem in the environment and atmosphere (surrounding temperature, wind etc.) ▪ Confirm that set contents of various parameters (Measurement range, sensor correction, customer scale calibration etc) are correct. |
| 2. PV display becomes '-----'. | <ul style="list-style-type: none"> ▪ It indicates excessive input or higher limit burn out for measurement range. Confirm the sensor signal. |
| 3. PV display becomes '-----'. | <ul style="list-style-type: none"> ▪ It indicates very little input or lower limit burn out for measurement range. Confirm the sensor signal. |
| 4. Control is not stable. | <ul style="list-style-type: none"> ▪ Confirm that there is no problem with the wiring of the actuator. ▪ Confirm that the terminal screw is tightened properly. ▪ Confirm that there is no noise. ▪ Confirm that the set contents of various parameters (PID, output limiter etc.) are correct. <p>※ Regarding controllability, it is necessary to do the design/adjustment not only in just the controller but in the entire system of the final product. If the controllability does not improve even on adjusting the set contents of various parameters (PID etc.) of the controller, consult the designer of this final product.</p> |
| 5. 'ERR' of status display lights. | <ul style="list-style-type: none"> ▪ It indicated abnormality in taking the input. In addition to chances of abnormality in the internal circuit of the controller, it might be adversely affected by noise also, hence confirm that there is no noise. |
| 6. Cause unclear however operation is strange | <ul style="list-style-type: none"> ▪ Confirm that the contents of various parameters are correct. ▪ Even then if the operation of the controller is strange, initialize the set contents. Do all the settings again and confirm that there is no problem in it. |

| | |
|---|--|
| 7. Lower display is not displayed normally, displayed strips. | <ul style="list-style-type: none"> Set the proper value of the [Display contrast] in mode11. 40 to 70% of range is suitable setting value. When setting the range of 80 to 100%, stripes appear in the LCD. The setting value is set the initial value (50%) in ordinary use. |
| 8. Error message is displayed when setting the parameter | <ul style="list-style-type: none"> After confirming error message, change to the correct setting because of the setting which is not registered. |
| 9. Error message is displayed when starting operations | <ul style="list-style-type: none"> After confirming error message, change to the correct setting because of the setting which is not started operation. |

When problems are not improved after executing the above troubleshooting, contact the dealer or your local CHINO's sales agent.

| | |
|---|--|
|  Warning | <p>When repair or modification of this instrument is needed, contact the dealer or your local CHINO's sales agent. Make sure that no persons other than service engineers approved by CHINO CORPORATION do not repair or modify this instrument by replacing parts.</p> <p>The data of settings may be deleted during repairing for unexpected trouble (power failure, earthquake, or other unexpected accident).</p> <p>Backup the data of settings before having the instrument repaired. We are not responsible for the lost or damaged data.</p> |
|---|--|

13. Checking and maintenance

13-1. Checking

13-1-1. Checking according to the trial operation

Every time before starting the operation, do a trial operation and confirm that the final product is correct.

13-1-2. Checking the accuracy

For the controller, depending on the requirement of the client periodical accuracy checking is necessary. Due to secular changes, these may slightly drift from accuracy, from the time when it was purchased.

Accuracy checking is done in our company hence consult your dealer or our company's nearest office.

13-1-3. Overhaul

Since the controller is reliable, we recommend an over oiling after 2-3 years. For ordering overhaul contact your dealer or our company's nearest office.

13-2. Life component

Clear life component of the controller is as follows.

Please understand that secular changes and aging occurs in almost all the products.

| Component name | Estimated life |
|--|---|
| 1. Relay × Relay for control, relay for alarm. | Approximately one hundred thousand times |
| 2. Electrolysis condenser × Condenser for smoothness of electric circuit. | Approximately 5 years (Surrounding temperature: 30°C, operation time: 12 hours/day) |
| 3. Battery × Battery for memory backup. | Approximately 10 years (Surrounding temperature: 30°C, operation time: 12 hours/day) |

13-3. Disposal



Precaution

- ① A small amount of hazardous substance below the specified level with RoHS directive is included in this controller.
- ② When disposing the controller always request a professional to do it, or dispose the controller in according to the garbage collection method of the each community.
- ③ This controller uses lithium battery. When disposing the controller, always request a professional to do it.
- ④ Separate the box, plastic bags, and cushioning materials the controller is packaged in according to the garbage collection method of the each community, and please cooperate to recycle.

14. Explanation of terms

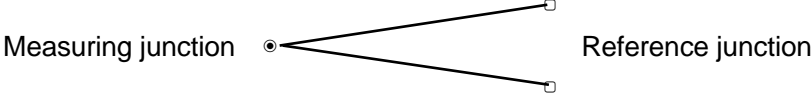
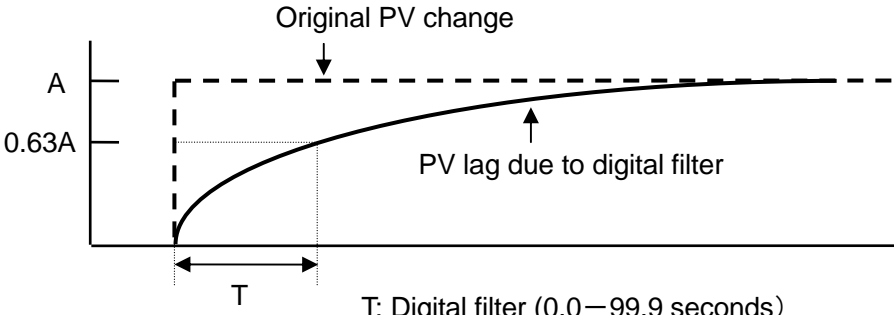
| Term | Explanation |
|------------------------------|--|
| Unit | Only for thermocouple or resistance thermometer select °C or K. Operation equation is as follows. <ul style="list-style-type: none"> • °C = K-273.15 • K = °C + 273.15 |
| RJ (Reference Junction) | <p>Thermocouple has measurement junction (temperature measurement side) and reference junction (electromotive force generation side) and reference junction decides the standards of thermo-electromotive force table (with scale) at 0°C condition.</p> <div style="text-align: center;">  </div> <p>When connecting the thermocouple to terminal of the controller, usually the temperature of the terminal becomes same as the surrounding temperature and is not 0°C. As a result, unless that temperature is compensated correct temperature cannot be measured. That compensation that is done automatically in the product internally is called the compensation function 'RJ'.</p> |
| Sensor correction | It is a function that corrects the PV (measurement value). It can also be used as zero point adjustment of sensor signal. |
| PV decimal point | It is a function that enables the selection of decimal point function of PV (measurement). Decimal point position can be selected from 5 digits display. |
| SV decimal point for display | This is a function for changing position of the decimal point of SV at the upper display. For example, when number of digits after decimal point is not displayed, use this function. |
| Digital filter | <p>It is a filter function on the operation having first order lag in PV (measurement value). Setting value of digital filter is equivalent to time constant (T), and when PV is changed during step condition it is equivalent to the time (seconds) to reach approximately 63%.</p> <div style="text-align: center;">  </div> <p style="text-align: right;">T: Digital filter (0.0—99.9 seconds)</p> |

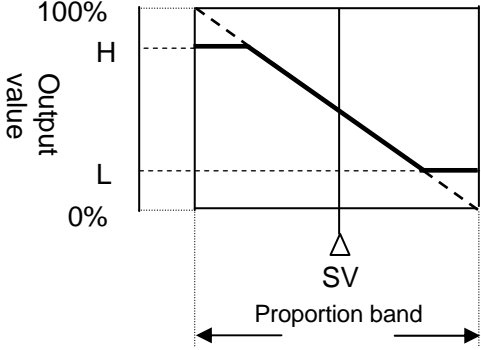
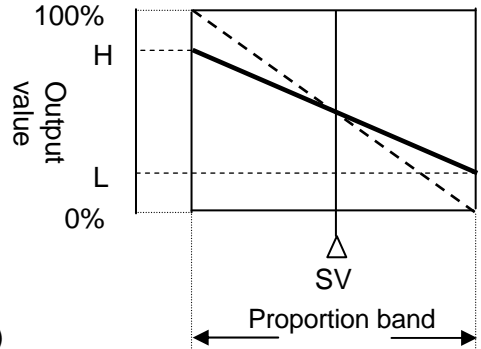
| Term | Explanation |
|--------------------------------------|---|
| Output limiter | <p>It is a function that sets higher Limit and lower limit in a range from -5.0 to 105% in MV.</p> <p>All the MVs (output value) on the control, lie within the range of higher limit and lower limit that is set.</p>  <p>The graph shows 'Output value' on the y-axis with markers for 0%, L, and H, and '100%' at the top. A dashed line represents the ideal linear relationship. A solid line shows the output being limited to H for values above the setpoint (SV) and to L for values below SV. A horizontal double-headed arrow below the x-axis is labeled 'Proportion band'.</p> |
| Output scale | <p>It is a function that lays out MV from 0.0 to 100%, in a range from higher limit value to lower limit value that is set.</p> <p>All the MVs (output value) on the control, lie within the range of higher limit and lower limit that is set.</p> <p>※ Option (Specify when placing an order)</p>  <p>The graph shows 'Output value' on the y-axis with markers for 0%, L, and H, and '100%' at the top. A dashed line represents the ideal linear relationship. A solid line shows the output scaled from H at 0% to L at 100%. A horizontal double-headed arrow below the x-axis is labeled 'Proportion band'.</p> |
| Output variation limiter | <p>It is a function that limits the variation quantity of MV (output value), for each control cycle (approximately 0.1 seconds). For example when variation in MV is 50% and set value of output variation limiter is 5%, then approximately 0.1 seconds x 50 / 5 = approximately 1.0 seconds, to arrive to a variation of 50% approximately 1.0 seconds are required.</p> <p>By using this function appropriately, sudden variation in MV (output value) can be avoided and controllability can be improved.</p> <p>However, manual output (include immediately after switching manual to auto) and output during PV abnormality are not effect this function.</p> |
| Output preset | <p>It is a function that can set MV (output value) when SV = PV, when controlling only the P (proportion) operation.</p> |
| Preset manual | <p>By using external signal input, MV (Output value) can be forcefully changed to this setting value.</p> |
| Output at the time of PV abnormality | <p>It is a function that considers forcibly MV (output value) as set value when, PV (measurement value) exceeds the range (including higher limit burnout), is below range (including lower limit burnout).</p> <p>Separate settings can be done in case of over range (including higher limit burnout) and under range (including lower limit burnout). In case of internal data abnormality, MV (output value) is the same as that in case of over range (including higher limit burnout).</p> <p>In case of output 2 specifications, output 2 side is 0% for all conditions.</p> |

| | |
|--|--|
| <p>Pulse cycle</p> | <p>It is a function that sets one cycle time of output ON/OFF in case of ON OFF pulse type or SSR drive pulse type.</p> <p>The smaller the set value the better the controllability, however as the ON/OFF count increases the life span of relay etc. decreases. Set the highest possible value in the range such that there is no error in controllability.</p> |
| <p>Control operation</p> | <p>'Reverse operation' is a control operation for SV (Setting value) in which the lower the PV (measurement value) the bigger the MV (output value) and it is generally used at the time of heating operation.</p> <p>'Direct operation' is a control operation for SV (Setting value) in which the higher the PV (measurement value) the bigger the MV (output value) and it is generally used at the time of cooling operation.</p> <div style="display: flex; justify-content: space-around; align-items: flex-end;"> <div style="text-align: center;"> <p>[Reverse operation]</p> </div> <div style="text-align: center;"> <p>[Direct operation]</p> </div> </div> |
| <p>Output dead band (Two-position control operation)</p> | <p>It is a dead band of output operation of two-position control operation (when P=0%).</p> <p>The smaller the set value the better the controllability, however as the ON/OFF count increases the life span of relay etc. decreases. Set the highest possible value in the range such that there is no error in controllability.</p> <div style="text-align: right; margin-right: 50px;"> <p>[For reverse operation]</p> </div> |
| <p>Alarm dead band</p> | <p>It is a function that, activates the alarm at the alarm setting value during alarm activation and releases the alarm, when the dead band that is set in the alarm setting value exceeds the dead band that is set in alarm setting value during alarm release.</p> |

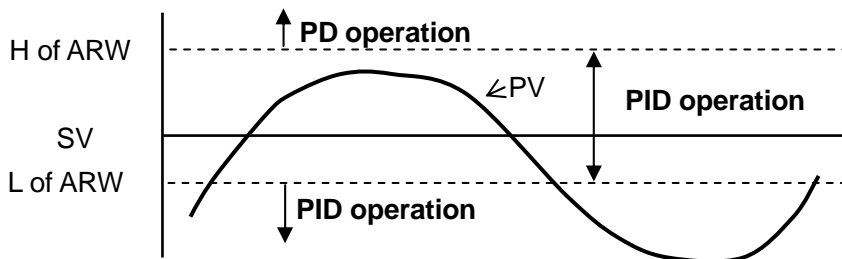
| | |
|--------------------------------------|---|
| <p>Alarm delay</p> | <p>In the function that has delay in alarm output, initial alarm is switched ON, when the judgment time of alarm ON is continuously equal to the setting value or more. If the judgment time of alarm ON, is less than the setting value, alarm is not switched ON. For example, if setting value of alarm delay is 5, when alarm is activated continuously for 5 seconds or more, initial alarm is switched ON. However when alarm is released it is switched OFF immediately.</p> |
| <p>A.R.W (Anti reset windup)</p> | <p>It is a function that decides the range of PID operation (especially I operation) in position type PID control. If this set value is exceeded, it becomes a PD operation.</p>  |
| <p>PV start</p> | <p>It is one of the functions in program operation and is a function that starts the SV (setting value) of program pattern from current PV (measurement value). When setting PV start, when operation status is changed from RESET to RUN, the operation starts from first identical SV in program pattern and PV at that time. If identical SV does not exist, SV is started and the operation starts from the first step. When pattern link is set, only initial pattern is enabled.</p> |
| <p>Real temperature compensation</p> | <p>In program operation, when progressing towards the next new step, if PV (measurement value) as against SV is not less than the setting value of real temperature compensation, when it enters the value less than the setting value stop the time there and perform constant value operation, and move to the next step and perform constant value operation at that point of time. Thus by using this function effectively, control operation according to the program pattern is possible. If set the small value, real temperature compensation may not work because of passing though next input taking.</p> |
| <p>Wait time alarm</p> | <p>In case of real temperature compensation operation, for value equal to or greater than the setting value of wait time alarm, it is a alarm function when constant value operation time lapses due to real temperature compensation operation.</p> |

15. Accessories

15-1. Front protective cover

It is a cover for protecting the front part also to protect the keys from being tampered.

During closed installation, it is not mounted but it is with front protective cover, the panel mounting interval of the controller is 105mm or more.

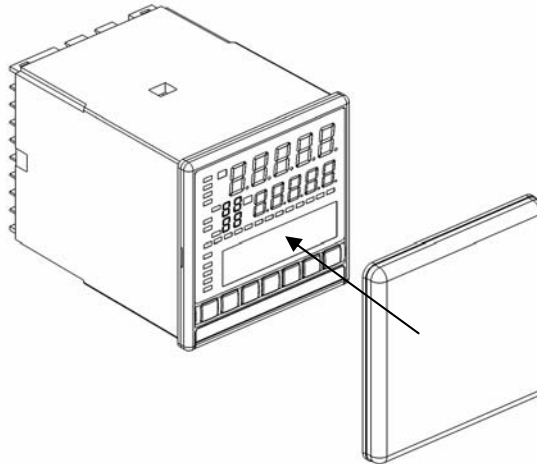

15-2. Contact protection element

Contact protection element is connected for noise rejection to the relay output terminal of the controller. Always do the loading and wiring through contact protection element and buffer relay in relay output like ON-OFF pulse type, ON-OFF servo type and alarm output.

Contact protection element as shown below is available with our company also, use it as per you requirement.

| Model | Specifications | Open close current | Application |
|--------|-----------------------------|--------------------|----------------|
| CX-CR1 | 0.01 μ F + 120 Ω | Less than 0.2A | For light load |
| CX-CR2 | 0.5 μ F + 47 Ω | 0.2A or more | For heavy load |

While using it, the leak current flows depending on the load power supply as shown below hence take care.

| Model | Power voltage: 200V | | Power voltage: 100V | |
|--------|---------------------|--------------------|---------------------|--------------------|
| | 50Hz | 60Hz | 50Hz | 60Hz |
| CX-CR1 | Approximately 2mA | Approximately 2mA | Approximately 1mA | Approximately 1mA |
| CX-CR2 | Approximately 45mA | Approximately 55mA | Approximately 23mA | Approximately 28mA |

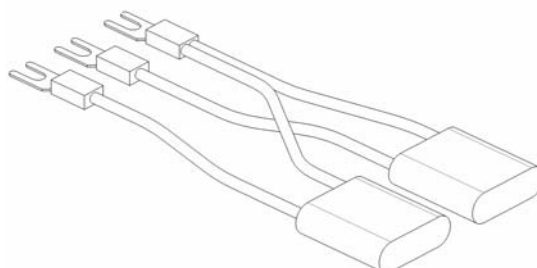

16. Specifications

■Input specifications

Thermocouple B, R, S, K, E, J, T, WRe5-WRe26,
W-WRe26, NiMo-Ni, CR-AuFe, N, PR5-20,
PtRh40-PtRh20, PlatineI II, U, L

DC voltage $\pm 10\text{mV}$, $\pm 20\text{mV}$, $\pm 50\text{mV}$, $\pm 100\text{mV}$,
 $\pm 5\text{V}$, $\pm 10\text{V}$

DC current 0 to 20mA

Resistance thermometer Pt100, JPt100, Old Pt100,
JPt50, Pt-Co (4-wires)

Measurement range : Thermocouple 28 types, DC voltage 6
types, direct current 1 type, resistance
thermometer 14 types

Temperature unit : °C, K

Accuracy rating : $\pm 0.1\% \pm 1$ digit of measurement range
For details see, 'Detailed accuracy rating
specifications'.

Reference junction compensation accuracy : $\pm 0.5^\circ\text{C}$
For details see, 'Reference junction compensation accuracy'.

Sampling rate: Approximately 0.1 seconds

Resolution : Approximately 1/30000

Burnout: Restricted to thermocouple, DC voltage (less than
 $\pm 50\text{mV}$), resistance thermometer (3-wire), high limit
burnout is a standard provision. During burnout,
output value of output 1 and output 2 can be set
optionally, and high limit alarm is ON (during high
limit burnout) however DC voltage ($\pm 100\text{mV}$ or
more), DC current, resistance temperature (4 wire
system) are not provided.

Input impedance : Thermocouple $1\text{M}\Omega$ or more
DC voltage $1\text{M}\Omega$ or more
Direct current approximately 250Ω

Allowable signal source resistance :
Thermocouple Less than 100Ω
DC voltage (mV) Less than 100Ω
DC voltage (V) Less than 300Ω

Allowable wire resistance : Resistance thermometer
Less than 5Ω (Should be common for all wires)

Measurement current of resistance thermometer :
Approximately 1mA

Maximum allowable input : Thermocouple Less than $\pm 20\text{V}$
DC voltage Less than $\pm 20\text{V}$
DC voltage Less than $\pm 30\text{mA}$,
Less than $\pm 7.5\text{V}$
Resistance thermometer
Less than 500Ω ,
Less than $\pm 5\text{V}$

Maximum common mode voltage : Less than 30VAC

Common mode rejection ratio : 130dB or more (50/60Hz)

Normal mode rejection ratio : 50dB or more (50/60Hz)

■Display specifications

Upper display : LED
Lower display : LCD (with back light) 108x24 dot

■Control specifications

Control cycle : Approximately 0.1 seconds

Output format : ON-OFF pulse type, ON-OFF servo type,
current output type, SSR drive pulse type,
voltage output type

ON-OFF pulse type :

| | |
|--------------------|--|
| Output signal | ON-OFF pulse conductive signal |
| Contact capacity | Resistance load Less than 100 to 240VAC and 5A Less than 30VDC and 5A |
| | Inductive load Less than 100 to 240VAC and 2.5A Less than 30VDC and 2.5A |
| | Smallest load 5VDC and 10mA or more |
| Contact protection | Build in a small type of CR device |

ON OFF servo type :

| | |
|-----------------------------------|---|
| Output signal | ON-OFF servo inductive signal |
| Contact capacity of standard load | Resistance load Less than 100 to 240VAC and 5A Less than 30VDC and 5A |
| | Inductive load Less than 100 to 240VAC and 2.5A Less than 30VDC and 2.5A |
| | Smallest load 5VDC and 10mA or more |
| Contact capacity of light load | Resistance load Less than 100 to 240VAC and 20mA Less than 30VDC and 20mA |
| | Inductive load Less than 100 to 240VAC and 20mA Less than 30VDC and 20mA |
| | Smallest load 5VDC and 1mA or more |
| Contact protection | Build in a small type of CR device |

Current output type : Output signal 4 to 20mA
Load resistance Less than 750Ω

SSR drive pulse type : Output signal ON-OFF pulse voltage
signal

| | |
|----------------|--|
| Output voltage | ON voltage $12\text{VDC} \pm 20\%$ OFF voltage Less than 0.8VDC |
| Load current | Less than 20mA |

Voltage output type : Output signal 0 to 10V
Output impedance Approximately 10Ω
Load resistance $50\text{k}\Omega$ or more

■ Alarm specifications

Alarm points : 4 points

Alarm type : Absolute value alarm, deviation alarm, absolute value deviation alarm, setting value alarm, output value alarm, control loop abnormal alarm, FAIL, Timer

Output signal : Relay output signal (a contact)
COM common for AL1 and AL2, COM common for AL3 and AL4

Contact capacity

Resistance load Less than 100 to 240VAC and 3A
Less than 30VDC and 3AInductive load Less than 100 to 240VAC and 1.5A
Less than 30VDC and 1.5A

Smallest load 5VDC and 10mA or more

■ General specifications

Rated power voltage : General power supply specifications

100 to 240VAC

24V Power supply specifications

24VAC/24VDC

Rated power supply frequency :

General power supply

50/60Hz

24V Power supply specification

DC, 50/60Hz

Maximum power consumption:

General power supply specifications

Without option 100VAC 10VA

240VAC 15VA

With option 100VAC 15VA

240VAC 20VA

24V Power supply specifications

Without option 24VAC 10VA

24VAC 5W

With option 24VAC 15VA

24VAC 10W

Power failure countermeasures :

Storing the setting contents using EEPROM
(Rewrite count Less than one million times)

Terminal screw : M3.5

Insulation resistance :

Between primary terminal and secondary terminal
20MΩ or more (500VDC)Between primary terminal and grounding terminal
20MΩ or more (500VDC)Between secondary terminal and grounding terminal
20MΩ or more (500VDC)

Withstand voltage :

Between primary terminal and secondary terminal
1500VAC (For 1 minute)Between primary terminal and grounding terminal
1500VAC (For 1 minute)Between secondary terminal and grounding terminal
500VAC (For 1 minute)

※ Primary terminal: Terminal of power supply (100 to 240VAC), control output, and alarm output

Secondary terminal: All terminals except primary terminal,
power supply (24VAC/24VDC)

Casing : Fire- retardant Polycarbonate

Color : Gray or black

Mounting: Panel mounting

External dimensions : 96(H)x96(W)x127(D)

(Depth from panel screen is 120)

Weight: Without option Approximately 450g

With option Approximately 580g

■ Safety standards

CE approval: EN61326: 1997 +A1+A2+A3

EN61010-1:2001

(Over voltage category II, pollution level 2)

※ Due to the test condition of EMC directive, indication value or output value which is equivalent to maximum $\pm 10\%$ or maximum $\pm 2\text{mV}$ which ever is greater, changes.

UL file No: E214646

UL :UL61010-1 2nd edition

c-UL :CAN/CSA C22.2 No.61010-1-04

■ Reference operation conditionSurrounding temperature : $23^{\circ}\text{C} \pm 2^{\circ}\text{C}$ Surrounding humidity : $55\%\text{RH} \pm 5\%$ (With no condensation)

Power voltage : General power supply specifications

100VAC $\pm 1\%$

24V Power supply specifications

24VDC $\pm 1\%$

Power supply frequency :

General power supply specifications

50/60Hz $\pm 0.5\%$

24V Power supply specifications

DC

Mounting orientation : Forward or backward $\pm 3^{\circ}$, lateral $\pm 3^{\circ}$

Set up height : Altitude below 2000m

Vibrations : 0m/s^2 Shocks : 0m/s^2

Mounting condition : Simple panel mounting (There should be a space above below and to the right and left)

Wind : None

External noise : None

Warm up time : 30 minutes or more

■ Normal operation conditionSurrounding temperature : -10°C to 50°C (-10°C to 40°C for closed installation)

Surrounding humidity : 10 to 90%RH (With no condensation)

Power voltage : General power supply specifications

90 to 264VAC

24V Power supply specifications

21.6-26.4VDC/AC

Power supply frequency :

General power supply specifications

50/60Hz $\pm 2\%$

24V power supply specifications

DC, 50/60Hz $\pm 2\%$ Mounting orientation : Forward or backward $\pm 10^{\circ}$, lateral $\pm 10^{\circ}$

Set up height : Altitude below 2000m

Vibrations : 2m/s^2 Shocks : 0m/s^2

Mounting condition : Simple panel mounting (There should be space above and below)

External noise : None

Surrounding temperature variation ratio : Less than $10^{\circ}\text{C}/\text{hour}$

■ Transport conditions

Surrounding temperature : -20°C to 60°C

Surrounding humidity : 5-90%RH (With no condensation)

Vibrations : 4.9m/s² (10 to 60Hz)

Shocks : 392m/s²

However these are the factory shipping packing conditions.

■ Storage conditions

Surrounding temperature : -20°C to 60°C

However temperature for long term preservation is 10°C to 30°C.

Surrounding humidity : 5 to 90%RH (With no condensation)

Vibrations : 0m/s²

Shocks : 0m/s²

However these are the factory shipping packing conditions.

■ Option

[Transmission signal output]

Number of outputs : Maximum 2 points

Output signal: 4-20mA (Load resistance Less than 400Ω)

0-1V (Output impedance Approx.10Ω)
(Load resistance More than 50kΩ)

0-10V (Output impedance Approx.10Ω)
(Load resistance More than 50kΩ)

Accuracy rating : High accuracy type ±0.1%F

General type ±0.3%FS

Resolution : High accuracy type Approx. 1/30000

General type Approximately 1/15000

Output update period : Approx. 0.1 second

Insulation : Internal circuit is insulated (More than
20MΩ/500VDC)

Transmission signal outputs are also insulated

[Transmitter power supply]

Power supply voltage : 24VDC±10%

Maximum current capacity : Less than 30mA

Insulation : Internal circuit is insulated (20MΩ or more and
500VDC)

[Communications interface]

Communications points : Maximum 2 points

Communications types : RS232C, RS422A, RS485

Protocol : MODBUS(RTU), MODBUS(ASCII), PRIVATE

Insulation : Internal circuit is insulated (20MΩ or more and
500VDC)

Communications interface points are not insulated

[Heater snapping wire alarm]

Measurement scope : 10 to 100AAC (50/60Hz)

Accuracy rating : ±5.0%FS±1digit

CT : Manufactured by U-RD Limited'CTL-12-S36-8'

[Output 2]

Control cycle : Approximately 0.1 seconds

Output format : ON-OFF pulse type, current output type,
voltage output type, SSR drive pulse type and
arbitrary combination is possible

Control system : PID system, SPRIT system

Insulation : Internal circuit is insulated (More than 20MΩ or
more and 500VDC)

Outputs are not insulated (Only ON-OFF pulse
type is insulated)

[External signal output]

Number of outputs : Maximum 20

Input signal : No-voltage contact, open-collector signal

External contact point capacity : 5VDC·2mA

Function : RUN/STOP

ADV

RESET

WAIT

FAST

Pattern No. selection

(6 points of PTN1/PTN2/PTN4/PTN8/PTN10/PTN20)

Manual output operation/Automatic output operation

(2 points of MAN1/AUTO1 and MAN2/AUTO2)

Preset manual/automatic output operation

Cancel alarm output

PV HOLD

Start/Reset timer

(4 points of TIMER1/TIMER2/TIMER3/TIMER4)

Insulation : Internal circuit is insulated (More than 20MΩ or
more and 500VDC)

External input points are not insulated

[External signal output]

Output points : Maximum 20 points

Output signal : No voltage contact point, open collector output

External contact point capacity : 24VDC·50mA

Function : Time signal 8 points

(TS1/TS2/TS3/TS4/TS5/TS6/TS7/TS8)

RUN/STOP

ADV

RESET

WAIT

END

Insulation : Internal circuit is insulated (More than 20MΩ or
more and 500VDC)

External signal output points are not insulated

[Panel sealing]

Corresponding to IEC60529 IP54

(Not possible during closed instrumentation)

[Terminal cover]

Cover the terminals for safe.

■ Detailed specifications of accuracy rating

| Input type | | Accuracy rating | Exceptional specifications |
|------------------------|--|------------------|--|
| Thermocouple | B | ±0.1%FS ±1digit | 0 to 400°C : Out of specifications 400 to 800°C : ±0.2%FS ±1digit |
| | R, S | | 0 to 400°C : ±0.2%FS ±1digit |
| | N | | |
| | K | | -200 to 0°C : ±0.2%FS ±1digit or ±60μV equivalent value, whichever is bigger |
| | E | | -270 to 0°C : ±0.2%FS ±1digit or ±80μV equivalent value, whichever is bigger |
| | J | | -200 to 0°C : ±0.2%FS ±1digit or ±80μV equivalent value, whichever is bigger |
| | T | | -270 to 0°C : ±0.2%FS ±1digit or ±40μV equivalent value, whichever is bigger |
| | U | | -200 to 0°C : ±0.2%FS ±1digit Or ±40μV equivalent value, whichever is bigger |
| | L | | -200 to 0°C: ±0.2%FS ±1digit |
| | WRe5-WRe26 | | |
| | W-WRe26 | | 0 to 400°C: ±0.3%FS ±1digit |
| | NiMo-Ni | | |
| | Platinel II | | |
| | CR-AuFe | | ±0.2%FS ±1digit |
| PR5-20 | 0 to 100°C : Out of specifications 100 to 200°C : ±0.5%FS ±1digit | | |
| PtRh40-PtRh20 | 0 to 400°C : ±1.5%FS ±1digit 400 to 800°C : ±0.8%FS ±1digit | | |
| DC voltage/DC current | | ±0.1%FS ±1digit | |
| Resistance thermometer | Pt100 Old Pt100 JPt100 | ±0.1%FS ±1digit | Applicable when measurement range is “-100 to 100°C, -100 to 100°C : ±0.15%FS ±1digit |
| | JPt50 | | |
| | Pt-Co | ±0.15%FS ±1digit | 4 to 20K : ±0.5%FS ±1digit 20 to 50K : ±0.3%FS ±1digit |

※ It is the measurement range conversion accuracy in reference operating conditions. Reference compensation accuracy is added in case of Thermocouple.1995

WRe5-WRe26, W-WRe26, NiMo-Ni, Platinel II, CR-AuFe, PtRh40-PtRh20:ASTM Vol. 14.03

U, L:DIN43710-1985

Pt100:IEC751(1995), JIS C 1604-1997

Old Pt100:IEC751(1983), JIS C 1604-1989, JIS C 1606-1989

JPt100:JIS C 1604-1981, JIS C 1606-1986

JPt50:JIS C 1604-1981

■ Reference compensation accuracy

| | | |
|----------------------------|--|---|
| K, E, J, T, N, Platinel II | ±0.5°C Or ±20μV equivalent value, whichever is more | ±1.5 °C Or ±60μV equivalent value, whichever is more |
| K, E, J, T, N, Platinel II | ±0.5°C Or ±20μV equivalent value, whichever is more | ±1.5 °C Or ±60μV equivalent value, whichever is more |
| Other than mentioned above | ±1.0°C Or ±40μV equivalent value, whichever is more | ±3.0°C Or ±120μV equivalent value, whichever is more |

※It is the compensation accuracy considered when measurement input value in 0°C. In case of measurement value other than 0°C, above-mentioned electromotive force conversion equivalent value is considered as the compensation accuracy.

17. Parameter list

[Parameters not linked to Program Pattern]

| Mode No. | Setting Item | Default value (During factory shipment) | Customer setting value | Setting range | |
|---------------------------|----------------------------------|--|------------------------|--|--|
| 0 | Running SV and time | SV | 0000.0 | SV range | |
| | | Time | 000:00 | 000:00 to 999:59 | |
| | Running PID | P | 005.0% | | 000.0 to 999.9 (0 is two-position control) |
| | | I | 0060s | | 0000 to 9999 (0 is ∞) |
| | | D | 0030s | | 0000 to 9999 (0 is OFF) |
| | Running second output PID | P | 005.0% | | 000.0 to 999.9 |
| | | I | 0060s | | 0000 to 9999 (0 is ∞) |
| | | D | 0030s | | 0000 to 9999 (0 is OFF) |
| | Running alarm 1 and alarm 2 | AL1 | 3000.0 | | -1999.9 to 3000.0 |
| | | AL2 | -1999.9 | | |
| | Running alarm 3 and alarm 4 | AL3 | 3000.0 | | |
| | | AL4 | -1999.9 | | |
| | Running output limiter | L | 000.0% | | -05.0 to 100.0 |
| | | H | 100.0% | | 000.0 to 105.0 |
| | Running output variation limiter | UP | 100.0% | | 000.1 to 100.0 |
| | | DOWN | -100.0% | | -100.0 to -000.1 |
| | Running output preset | | 050.0% | | -100.0 to 100.0 |
| Running sensor correction | | 0000.0 | | -199.99 to 200.00 | |
| Running A.R.W. | L | -050.0% | | -100.0 to 000.0 | |
| | H | 050.0% | | 000.0 to 100.0 | |
| Running subsidiary output | | 000.0% | | 000.0 to 100.0 | |
| SV correction | | 0000.0 | | -199.99 to 200.00 | |
| 1 | Run operation key lock | UNLOCK | | UNLOCK, LOCK | |
| | Cancel alarm output | NON | | NON, RESET | |
| | Auto tuning | END | | END, AT1, AT2, AT3, AT4 | |
| | Program drive system | MASTER KEY | | MASTER KEY, MASTER EXT SLAVE EXT, MASTER COM MASTER FREE | |
| | Pattern selection system | KEY | | KEY, EXT, COM, FREE | |
| | Time display system | PASS STEP | | PASS STEP, PASS PATTERN REMAIN STEP REMAIN PATTERN | |
| | Adjustment format | PROGRAM | | PROGRAM, CONST | |
| | PV Hold | NON | | NON, HOLD | |
| | Operation during power supply | CONTINUE | | CONTINUE, RESET | |
| | Existence of CT screen | NON | | NON, DISPLAY | |
| 2 | SV scope | -200.0 to 1370.0 | | -1999.9 to 3000.0 | |
| | Clear pattern | END | | EACH (01 to 30), ALL | |
| | Copy pattern | END | | PTN: (01 to 30) → (01 to 30), YES | |
| | SV during Reset | 0000.0 | | SV range | |
| | Time unit | HOUR:MIN | | HOUR:MIN, MIN:SEC | |

| Mode No. | Setting Item | | Default value (During factory shipment) | Customer setting value | Setting range | |
|--------------------------|---|-------------------------------|--|------------------------|--|---|
| 3 | Output 2 PID | P | 005.0% | | 000.0 to 999.9 (0 is two-position control) | |
| | | I | 0060s | | 0000 to 9999 (0 is ∞) | |
| | | D | 0030s | | 0000 to 9999 (0 is OFF) | |
| | Output 2 gap | | | 000.0% | | -100.0 to 100.0 |
| | Output dead band | PID | | 0.0% | | 0.0 to 9.9 |
| | | P=0 | | 0.5% | | 0.1 to 9.9 |
| | Output 2, output dead band | PID | | 0.0% | | 0.0 to 9.9 |
| | | P=0 | | 0.5% | | 0.1 to 9.9 |
| | Alarm format of alarm 1 and alarm 2 | AL1 | | DV-H | | PV, DV, ADV, SV, MV (MV1, MV2) H, HW, HK, HWK L, LW, LK, LWK CT, TIMER, WAIT, FAIL |
| | | AL2 | | DV-L | | |
| | Alarm format of alarm 3 and alarm 4 | AL3 | | DV-H | | |
| | | AL4 | | DV-L | | |
| | Alarm dead band | AL1 | | 002.00 | | 000.00 to 200.00 |
| | | AL2 | | 002.00 | | |
| AL3 | | | 002.00 | | | |
| AL4 | | | 002.00 | | | |
| Alarm delay | | | 0000.0s | | 0000.0 to 2000.0 | |
| AT2, AT3 start direction | | | UP | | UP, DOWN | |
| Control algorithm | | | POSITION | | POSITION, VELOCITY | |
| 4 | Output 2 limiter (or output 2 scale) | L | 000.0% | | -05.0 to 100.0 | |
| | | H | 100.0% | | 000.0 to 105.0 | |
| | Output 2 variation limiter | UP | | 100.0% | | 000.1 to 100.0 |
| | | DOWN | | -100.0% | | -100.0 to -000.1 |
| | Output when program ends | OUT1 | | CONTROL | | CONTROL, -005.0 to 105.0 |
| | | OUT2 | | CONTROL | | CONTROL, -005.0 to 105.0 |
| | Pulse cycle | | | 030s | | 001 to 180 |
| | Output 2 pulse cycle | | | 030s | | 001 to 180 |
| | FB tuning | | | END | | END, START |
| | FB zero span | Z | | 00.0% | | 00.0 to 99.9 |
| | | S | | 100.0% | | 000.1 to 100.0 |
| | FB dead band | | | 1.0% | | 0.5 to 5.0 |
| | Output during PV abnormality | OVR | | 000.0% | | -05.0 to 105.0 |
| | | UDR | | 000.0% | | |
| | Output during output 2 PV abnormality | OVR | | 000.0% | | -05.0 to 105.0 |
| | | UDR | | 000.0% | | |
| | Direct/Reverse control | | | REVERSE | | DIRECT, REVERSE |
| | Direct/Reverse control for output 2 | | | DIRECT | | DIRECT, REVERSE |
| Preset manual | | | 000.0% | | -005.0 to 105.0 | |
| Output 2 preset manual | | | 000.0% | | -005.0 to 105.0 | |
| Output 2 control system | | | PID | | PID, SPRIT | |
| SPRIT | DIR | | 0.0% | | 00.0 to 60.0 | |
| | REV | | 100.0% | | 40.0 to 100.0 | |
| 5 | Measurement range | Universal | | K1 | See 'Measurement range list' | |
| | | 4-wire resistance thermometer | | Pt100Q1 | See 'Measurement range list' | |
| | RJ | | | INT | INT, EXT | |

| Mode No. | Setting Item | Default value (During factory shipment) | Customer setting value | Setting range | |
|---|--|--|-------------------------------------|--|-------------------|
| 5 | Unit | °C | | °C,K | |
| | Measurement scope | -200.0 to 1370.0 | | Scale scope of measurement range | |
| | Linear scale | DOT | 1 | | 0 to 4 |
| | | Scale | 0000.0 to 2000.0 | | -1999.9 to 3000.0 |
| | PV decimal point | 1 | | 0 to 4 | |
| | Digital filter | 00.1s | | 00.0 to 99.9 | |
| SV decimal point for display | 1 | | 0 to 4 | | |
| 7 | Transmission type (High-performance type) | PV | | PV, SV, MV(MV1, MV2), MFB, SUB | |
| | Transmission scale (High-performance type) | -0200.0 to 1370.0 | | -1999.9 to 3000.0 | |
| | Transmission type (Normal type) | PV | | PV, SV, MV(MV1, MV2), MFB, SUB | |
| | Transmission scale (Normal type) | -0200.0 to 1370.0 | | -1999.9 to 3000.0 | |
| 8 | Communication speed | 9600bps | | 2400, 4800, 9600, 19200, 38400 | |
| | Instrument number | 01 | | 01 to 99 | |
| | Communications function | COM | | COM, TRANS | |
| | Communications transmission type | PV | | PV, SV, MV(MV1, MV2), MFB, SUB | |
| | Communications protocol | MODBUS(RTU) | | MODBUS(RTU), MODBUS(ASCII), PRIVATE | |
| | Communications character | 8BIT/NON/STOP1 | | | 7BIT/EVEN/STOP1 |
| | | | | | 8BIT/ODD/STOP2 |
| | Select communications 2 port function | ENG | | COM·ENG | |
| | Communications speed for COM2 | 9600bps | | 2400, 4800, 9600, 19200, 38400 | |
| | Instrument number for COM2 | 01 | | 01 to 99 | |
| | Communications function for COM2 | COM | | COM, TRANS | |
| | Communications transmission type for COM2 | PV | | PV, SV, MV(MV1, MV2), MFB, SUB | |
| Communications protocol for COM2 | MODBUS(RTU) | | MODBUS(RTU), MODBUS(ASCII), PRIVATE | | |
| Communications character for COM2 | 8BIT/NON/STOP1 | | | 7BIT/EVEN/STOP1 | |
| | | | | 8BIT/ODD/STOP2 | |
| 11 | Display backlight | AUTO | | GREEN, ORANGE, AUTO | |
| | Display contrast | 050% | | 000 to 100 | |
| | Key backlight | AUTO | | AUTO, OFF, ON | |
| | External signal layout | No allocation | | See 'External signal input' | |
| | Testing alarm output | OFF | | OFF, AL1, AL2, AL3, AL4 | |
| | Testing timer signal output | No. 0 | | No. 0 to 8 (0 is output OFF) | |
| | Testing status output | OFF | | OFF, RUN/STOP, ADVANCE RESET, WAIT, END | |
| 12 | Measurement range zero correction | 00.000 | | -19.999 to 20.000 | |
| | Measurement range span correction | 1.0000 | | 0.9000 to 1.1000 | |
| | Output 2 zero correction | 00.000 | | -10.000 to 10.000 | |
| | Output 1 span correction | 1.0000 | | 0.9000 to 1.1000 | |
| | Output 1 zero correction | 00.000 | | -10.000 to 10.000 | |
| | Output 2 span correction | 1.0000 | | 0.9000 to 1.1000 | |
| | Transmission output (High-performance type) zero correction | 00.000 | | | -10.000 to 10.000 |
| | | | | | 0.9000 to 1.1000 |
| | Transmission output (High-performance type) span correction | 1.0000 | | | 0.9000 to 1.1000 |
| | | | | | -10.000-10.000 |
| | Transmission output (Normal type) zero correction | 00.000 | | | -10.000 to 10.000 |
| | | | | | 0.9000 to 1.1000 |
| Transmission output (Normal type) span correction | 1.0000 | | | 0.9000 to 1.1000 | |
| | | | | -10.000 to 10.000 | |
| CT input zero correction | 00.000 | | -10.000 to 10.000 | | |
| CT input span correction | 1.0000 | | 0.9000 to 1.1000 | | |

[Parameters linked to Program Pattern]

MODE2

| | |
|-------------|--|
| Pattern No. | |
|-------------|--|

| | |
|---------------------------------|---|
| Pattern repeat: No/Yes (Times) | Pattern Link: No/Yes (Link destination pattern No.) |
|---------------------------------|---|

| | |
|---------------|--------------|
| Setting range | 0000 to 9999 |
|---------------|--------------|

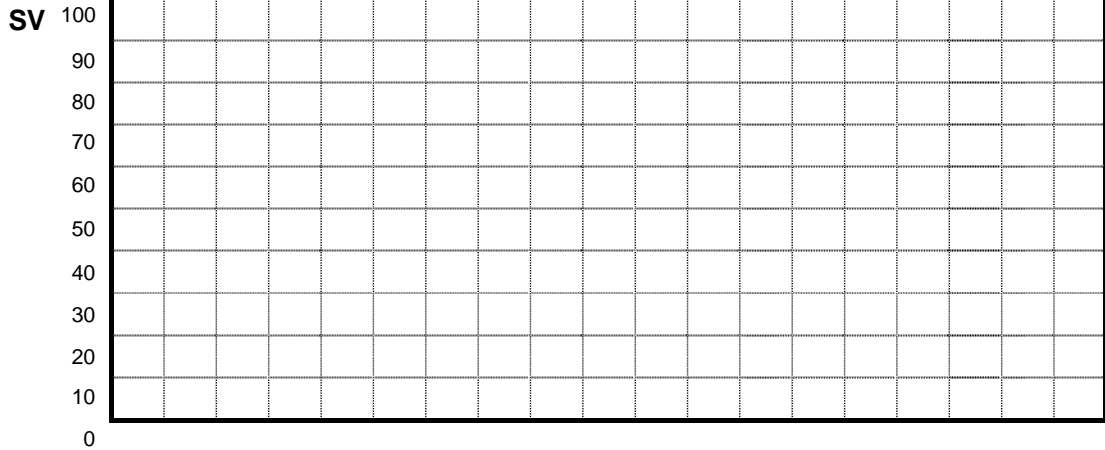

| | | | | | | | | | | | | | | | | | | | | |
|----------|----|----|----|----|----|----|----|----|----|----|----|----|----|----|----|----|----|----|----|----|
| Step No. | 00 | 01 | 02 | 03 | 04 | 05 | 06 | 07 | 08 | 09 | 10 | 11 | 12 | 13 | 14 | 15 | 16 | 17 | 18 | 19 |
|----------|----|----|----|----|----|----|----|----|----|----|----|----|----|----|----|----|----|----|----|----|

| | |
|---------------------------|----|
| Selection of start method | PV |
| | SV |

| | |
|-----------------|-------------|
| Program pattern | SV |
| | TIME |
| | Step repeat |

| | | | | | | | | | | | | | | | | | | | | | | | |
|--------------------|------------------------|-----|--|--|--|--|--|--|--|--|--|--|--|--|--|--|--|--|--|--|--|--|--|
| Sequence | PID | No. | | | | | | | | | | | | | | | | | | | | | |
| | Alarm | No. | | | | | | | | | | | | | | | | | | | | | |
| | A.R.W. | No. | | | | | | | | | | | | | | | | | | | | | |
| | Output limit | No. | | | | | | | | | | | | | | | | | | | | | |
| | Output variation limit | No. | | | | | | | | | | | | | | | | | | | | | |
| | Output preset | No. | | | | | | | | | | | | | | | | | | | | | |
| | Sensor compensation | No. | | | | | | | | | | | | | | | | | | | | | |
| | Time signal | TS1 | | | | | | | | | | | | | | | | | | | | | |
| | | TS2 | | | | | | | | | | | | | | | | | | | | | |
| | | TS3 | | | | | | | | | | | | | | | | | | | | | |
| | | TS4 | | | | | | | | | | | | | | | | | | | | | |
| | | TS5 | | | | | | | | | | | | | | | | | | | | | |
| | | TS6 | | | | | | | | | | | | | | | | | | | | | |
| | | TS7 | | | | | | | | | | | | | | | | | | | | | |
| | | TS8 | | | | | | | | | | | | | | | | | | | | | |
| Actual temperature | No. | | | | | | | | | | | | | | | | | | | | | | |
| Wait time alarm | No. | | | | | | | | | | | | | | | | | | | | | | |
| Auxiliary output | No. | | | | | | | | | | | | | | | | | | | | | | |

MODE3

| PID | | | |
|---------------|----------------|--------------|--------------|
| No. | P (%) | I (s) | D (s) |
| Default | 5.0 | 60 | 30 |
| 1 | | | |
| 2 | | | |
| 3 | | | |
| 4 | | | |
| 5 | | | |
| 6 | | | |
| 7 | | | |
| 8 | | | |
| 9-1 | | | |
| 9-2 | | | |
| 9-3 | | | |
| 9-4 | | | |
| 9-5 | | | |
| 9-6 | | | |
| 9-7 | | | |
| 9-8 | | | |
| Setting range | 000.0 to 999.9 | 0000 to 9999 | 0000 to 9999 |

| A.R.W. | | |
|---------------|------------------|----------------|
| No. | L (%) | H (%) |
| Default | -50.0 | 50.0 |
| 1 | | |
| 2 | | |
| 3 | | |
| 4 | | |
| 5 | | |
| 6 | | |
| 7 | | |
| 8 | | |
| Setting range | -100.0 to -000.0 | 000.0 to 100.0 |

| Alarm | | | | |
|---------------|-------------------|---------|--------|---------|
| No. | AL1 | AL2 | AL3 | AL4 |
| Default | 3000.0 | -1999.9 | 3000.0 | -1999.9 |
| 1 | | | | |
| 2 | | | | |
| 3 | | | | |
| 4 | | | | |
| 5 | | | | |
| 6 | | | | |
| 7 | | | | |
| 8 | | | | |
| Setting range | -1999.9 to 3000.0 | | | |

MODE4

| Output limit | | |
|---------------|----------------|----------------|
| No. | L (%) | H (%) |
| Default | 0.0 | 100.0 |
| 1 | | |
| 2 | | |
| 3 | | |
| 4 | | |
| 5 | | |
| 6 | | |
| 7 | | |
| 8 | | |
| Setting range | -05.0 to 100.0 | 000.0 to 105.0 |

| Output variation limit | | |
|------------------------|----------------|------------------|
| No. | UP (%) | DOWN (%) |
| Default | 100.0 | -100.0 |
| 1 | | |
| 2 | | |
| 3 | | |
| 4 | | |
| 5 | | |
| 6 | | |
| 7 | | |
| 8 | | |
| Setting range | 000.1 to 100.0 | -100.0 to -000.1 |

| Output preset | |
|---------------|------------------|
| No. | Preset value (%) |
| Default | 50.0 |
| 1 | |
| 2 | |
| 3 | |
| 4 | |
| 5 | |
| 6 | |
| 7 | |
| 8 | |
| Setting range | -100.0 to 100.0 |

MODE5

| Sensor compensation | |
|---------------------|--------------------|
| No. | Compensation value |
| Default | 0.0 |
| 1 | |
| 2 | |
| 3 | |
| 4 | |
| 5 | |
| 6 | |
| 7 | |
| 8 | |
| Setting range | -199.99 to 200.00 |

MODE6

| Time signal | | |
|---------------|------------------|--------|
| No. | ON | OFF |
| Default | 000:00 | 001:00 |
| 1 | | |
| 2 | | |
| 3 | | |
| 4 | | |
| 5 | | |
| 6 | | |
| 7 | | |
| 8 | | |
| Setting range | 000:00 to 999:59 | |

| Actual temperature compensation | |
|---------------------------------|------------------|
| No. | Deviation value |
| Default | 2000.0 |
| 1 | |
| 2 | |
| 3 | |
| 4 | |
| 5 | |
| 6 | |
| 7 | |
| 8 | |
| Setting range | 0000.1 to 2000.0 |

| Wait time alarm | |
|-----------------|------------------|
| No. | Wait time |
| Default | 001:00 |
| 1 | |
| 2 | |
| 3 | |
| 4 | |
| 5 | |
| 6 | |
| 7 | |
| 8 | |
| Setting range | 000:00 to 999:59 |

MODE7

| Auxiliary output | |
|------------------|----------------|
| No. | Output value |
| Default | 0.0 |
| 1 | |
| 2 | |
| 3 | |
| 4 | |
| 5 | |
| 6 | |
| 7 | |
| 8 | |
| Setting range | 000.0 to 100.0 |

[Parameters linked to auto tuning]

| Mode No. | Setting field | | Initial value (During factory shipment) | Customer setting value (Execution No.) | | | | | | | | Setting range | |
|----------|---------------|-----|--|--|---|---|---|---|---|---|---|---------------|----------------------------|
| | | | | 1 | 2 | 3 | 4 | 5 | 6 | 7 | 8 | | |
| 3 | SV for AT2 | Run | Only No.1 is ON | | | | | | | | | ON, OFF | |
| | | SV | Automatic development | | | | | | | | | | -19999 to 30000 |
| | SV for AT3 | Run | OFF | | | | | | | | | | ON, OFF |
| | | SV | Automatic development | | | | | | | | | | Auto PID switch between SV |

[Parameters linked to automatic PID switching system]

| Mode No. | Setting Item | | Default value (During default settings) | Customer setting value | | | | | | | | Setting range | |
|----------|---|---|--|------------------------|-----|-----|-----|-----|-----|-----|-----|---------------|---------------------------------|
| | | | | 9-1 | 9-2 | 9-3 | 9-4 | 9-5 | 9-6 | 9-7 | 9-8 | | |
| 3 | PID | P | 005.0% | | | | | | | | | | 000.0 to 999.9 |
| | | I | 0060s | | | | | | | | | | 0000 to 9999 |
| | | D | 0030s | | | | | | | | | | 0000 to 9999 |
| | Automatic PID switching system SV section | | Automatic development | | | | | | | | | | Measurement scope, linear scale |

18. Parameter directory list

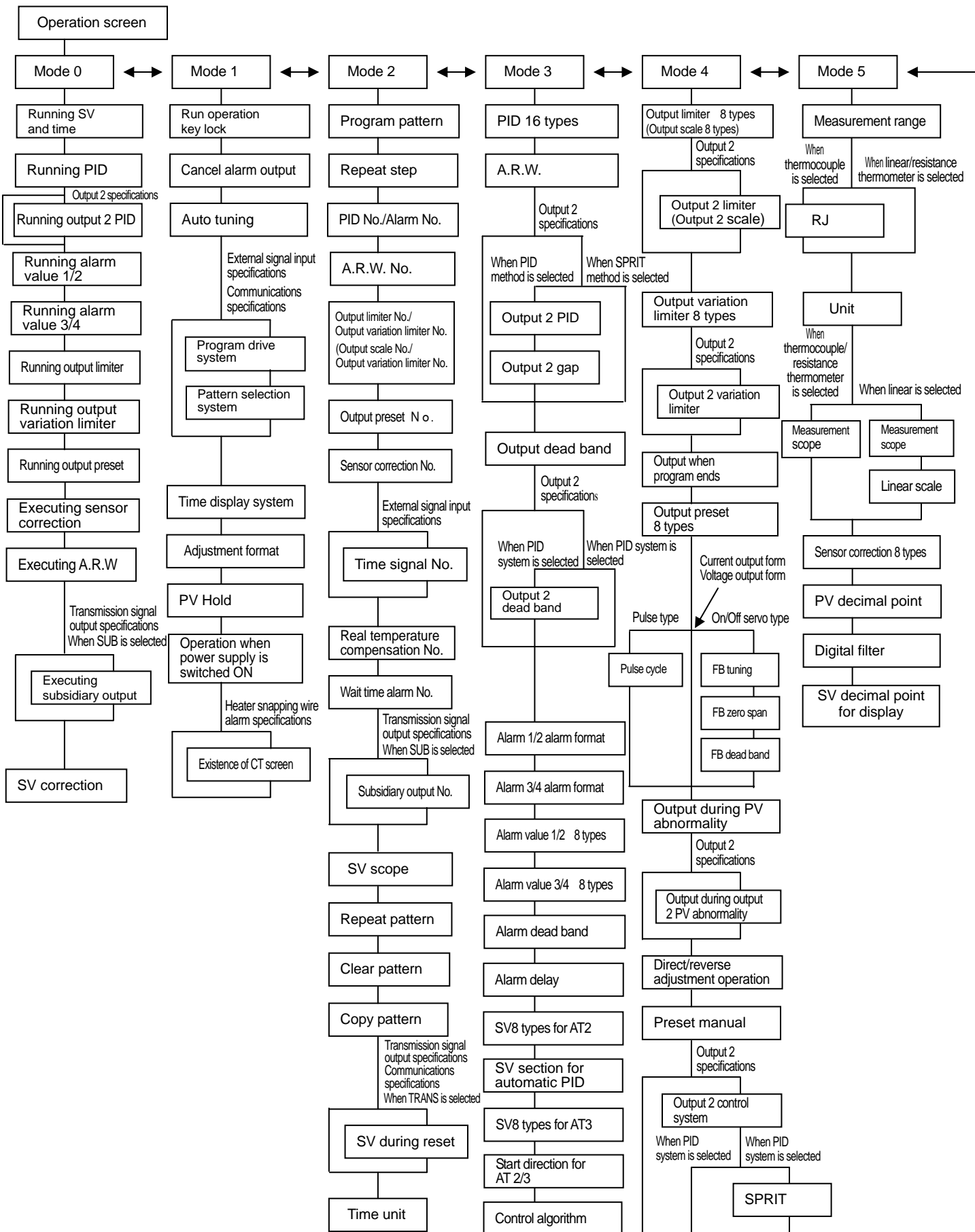

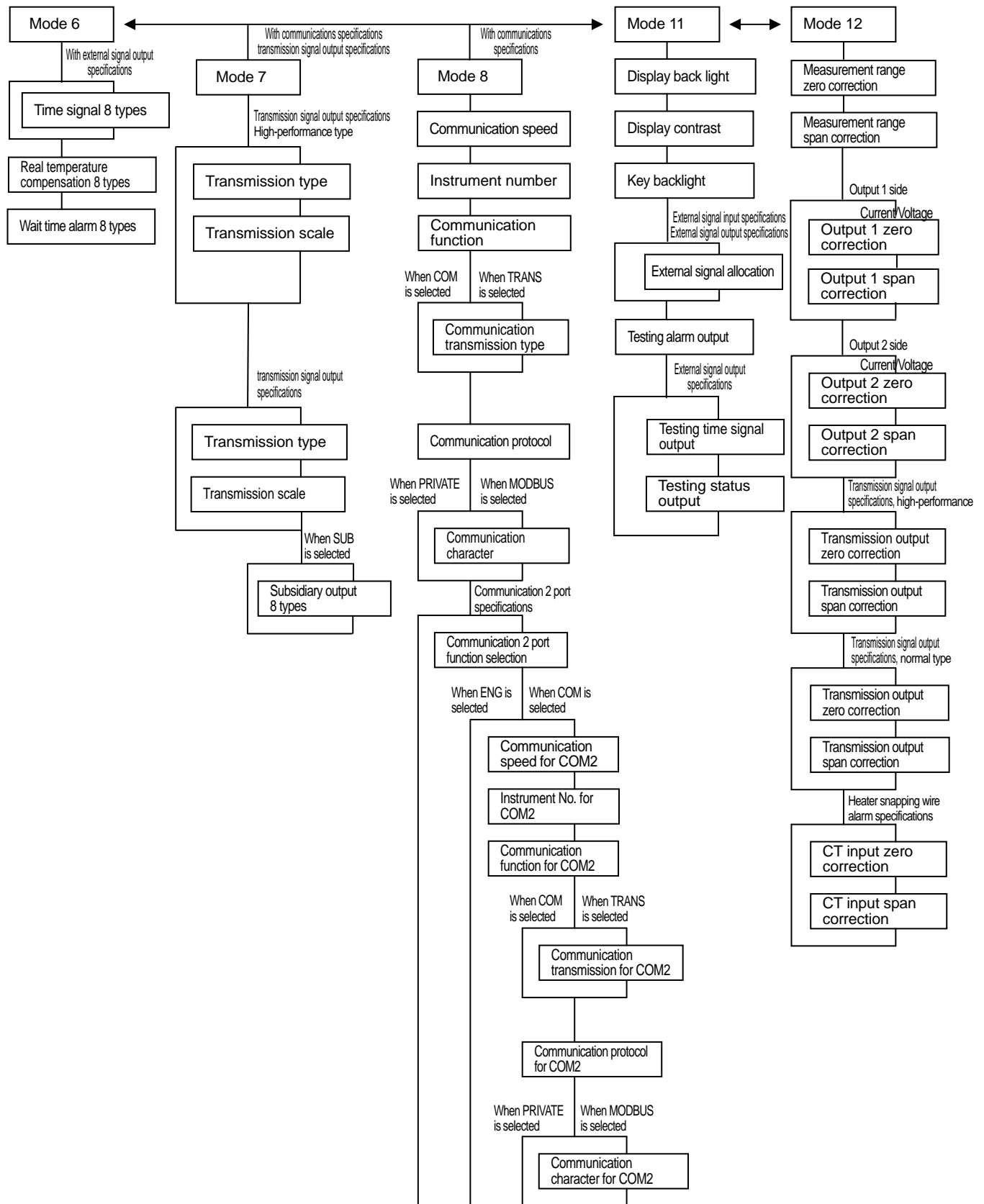

19. Engineering unit sticker

The controller is supplied with sticker for engineering unit. Fix it in the appropriate position as shown in the upper display as per your convenience.

Then if long time has passed after fixing this sticker, there may be peeling-off of the sticker or degradation of character printing due to adhesion degradation.



Precaution

Unincorporated measurement units that are not decided by the measurement laws are included in this unit seal.

CHINO

CHINO CORPORATION

32-8,KUMANO-CHO,ITABASHI-KU,TOKYO 173-8632

Telephone:81-3-3956-2171

Facsimile:81-3-3956-0915

E-mail: inter@chino.co.jp

